



# ICEBALL FX Operators Manual

Innovative Concepts in Entertainment  
10123 Main Street  
Clarence, NY 14031

(716) 759-0360 9am to 6pm Eastern Standard Time  
[WWW.ICEGAME.COM](http://WWW.ICEGAME.COM)

# Table Of Contents

Safety and Warnings	3
Before you Begin	4
Game Setup	5
Linking Multiple Games	11
Mega Bonus Setup	14
Program Options	16
Error Codes	17
Warranty	18

## SAFETY AND WARNINGS BEFORE YOU BEGIN

WARNING: WHEN INSTALLING THIS GAME, A GROUNDED A.C. RECEPTACLE MUST BE USED. FAILURE TO DO SO COULD RESULT IN INJURY TO YOURSELF OR OTHERS. FAILURE TO USE A GROUNDED RECEPTACLE COULD ALSO CAUSE IMPROPER GAME OPERATION, OR DAMAGE TO THE ELECTRONICS.

**NOTE: THIS GAME IS INTENDED FOR INDOOR USE ONLY.**

DO NOT DEFEAT OR REMOVE THE GROUNDING PRONG ON THE POWER CORD FOR THE SAME REASON AS GIVEN ABOVE. USING AN IMPROPERLY GROUNDED GAME COULD VOID YOUR WARRANTY.

HAVE A QUALIFIED ELECTRICIAN CHECK YOUR A.C. RECEPTACLE TO BE SURE THE GROUND IS FUNCTIONING PROPERLY.

THIS GAME IS DESIGNED TO DISSIPATE STATIC ELECTRICITY THROUGH THE GROUNDING PLANE OF THE GAME. IF THE A.C. GROUND DOES NOT WORK, THE GAME COULD DISCHARGE STATIC ELECTRICITY THROUGH THE GAME CIRCUITRY, WHICH COULD CAUSE DAMAGE.

THE POWER SUPPLY IS NOT VOLTAGE ADJUSTABLE. TO OPERATE THE GAME AT VOLTAGES OTHER THAN THOSE IT WAS DESIGNED FOR. PLEASE CONTACT OUR SERVICE DEPARTMENT FOR VOLTAGE CONVERSION INFORMATION.

### WARNING

DO NOT remove any of the components on the main board (e.g. compact flash and EPROMS) while the game is powered on. This may cause permanent damage to the parts and the main board. Removing any main board component part while powered on will void the warranty.

ALWAYS REMOVE POWER TO THE GAME, BEFORE ATTEMPTING ANY SERVICE, UNLESS NEEDED FOR SPECIFIC TESTING. FAILURE TO OBSERVE THIS PRECAUTION COULD RESULT IN SERIOUS INJURY TO YOURSELF OR OTHERS.

THIS GAME IS NOT SUITABLE FOR INSTALLATION IN AN AREA WHERE A WATER JET COULD BE USED.

This appliance is not intended for use by persons (including children) with reduced physical, sensory or mental capabilities, or lack of experience and knowledge, unless they have been given supervision or instruction concerning use of the appliance by a person responsible for their safety. Children should be supervised to ensure that they do not play with the appliance.

The game's foot print is 120" x 30" x 84".

### AC Power Information

The games main fuse is accessed through the back of the game at the power mod. Above the power cord is a small panel that contains the main fuse. The value of the fuse for 110 volt users is 3 AMPS at 250Volt type slow blow. The value of the fuse for 220 users is 1.5 AMPS at 250Volt type slow blow.



**\*\* STOP \*\***

Before you begin to assemble your game locate the parts box and ensure all parts are present.

If any parts are missing please contact ICE Service at (716) 759-0360 Mon-Fri 9am to 6pm Eastern Standard.



Phone coupler (attached to one side of the game already).

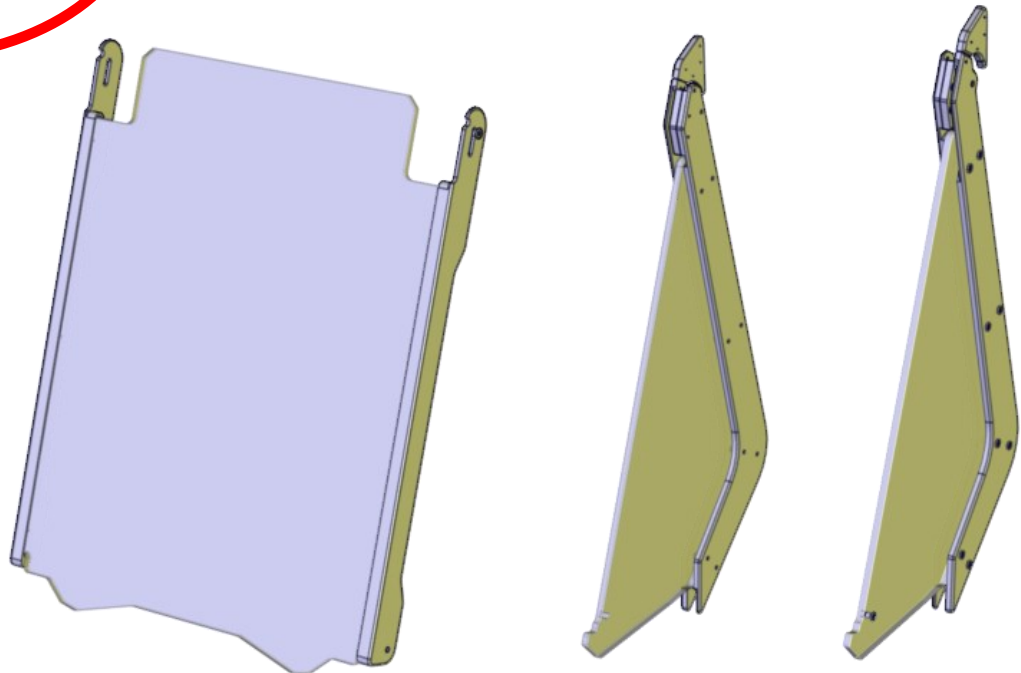

## STEP 1:

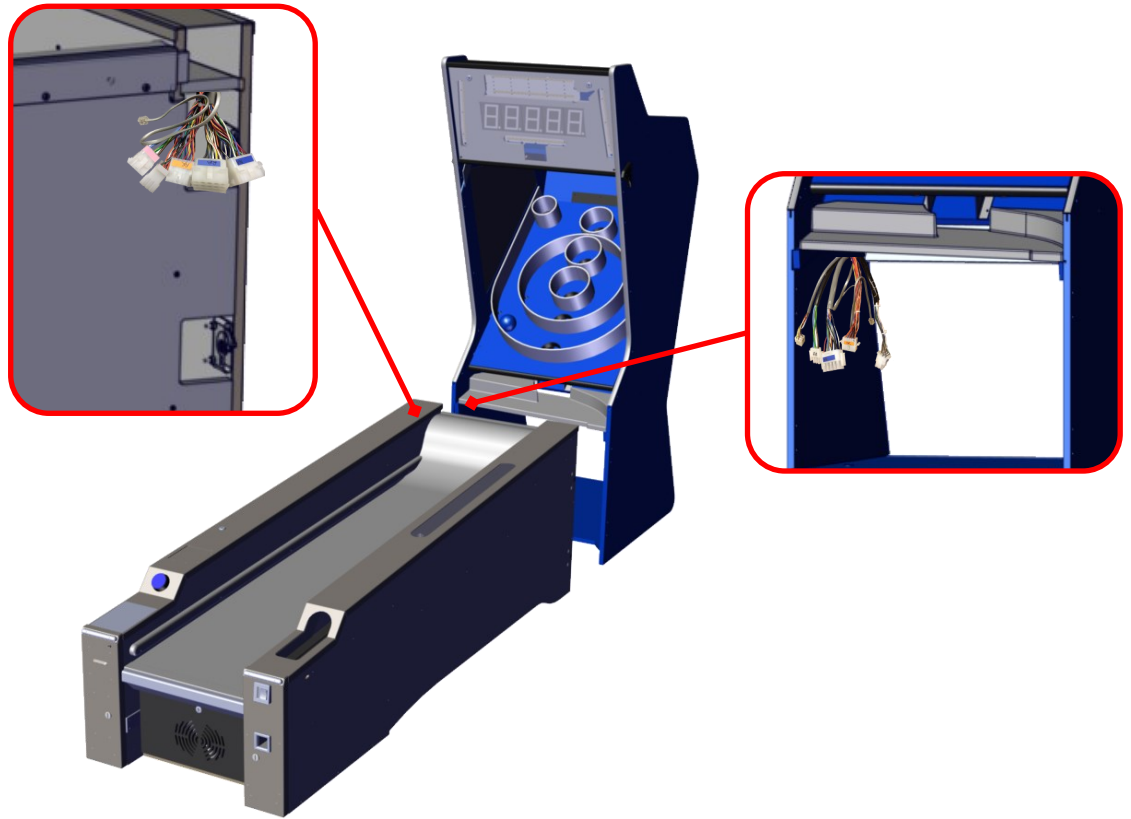

Position the front and back cabinets leaving a space to connect the wire harnesses. Each of the harnesses are color coded. Attach the phone cords together using the provided coupler.

## STEP 2:

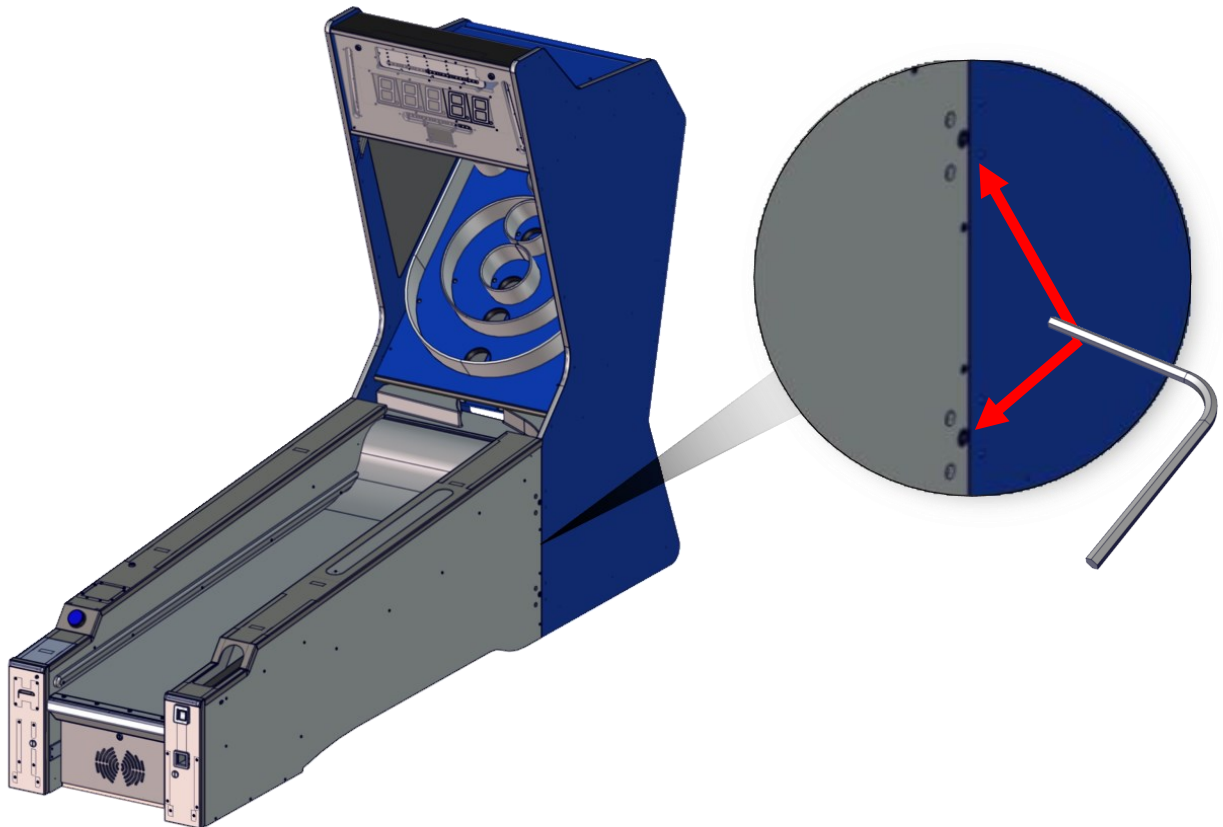

Using the provided latch tool and on both sides of the cabinet insert the tool into the latch openings and turn clockwise until the cabinet pulls together and the locks.

**STEP 3:**

Unlock coin door and slide door open.



**STEP 4:**

Slide Ball rail cover forward.



**STEP 5:**

Lift Ball rail cover up and put aside.

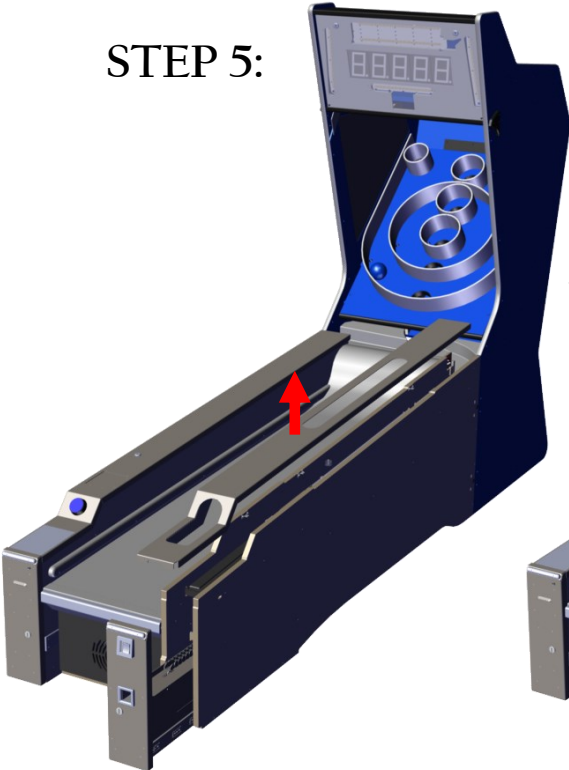

## STEP 6:

Remove the two foam packs on the top and lift ball rail assembly up and out. Remove the foam pack beneath. Re-install ball rail assembly.

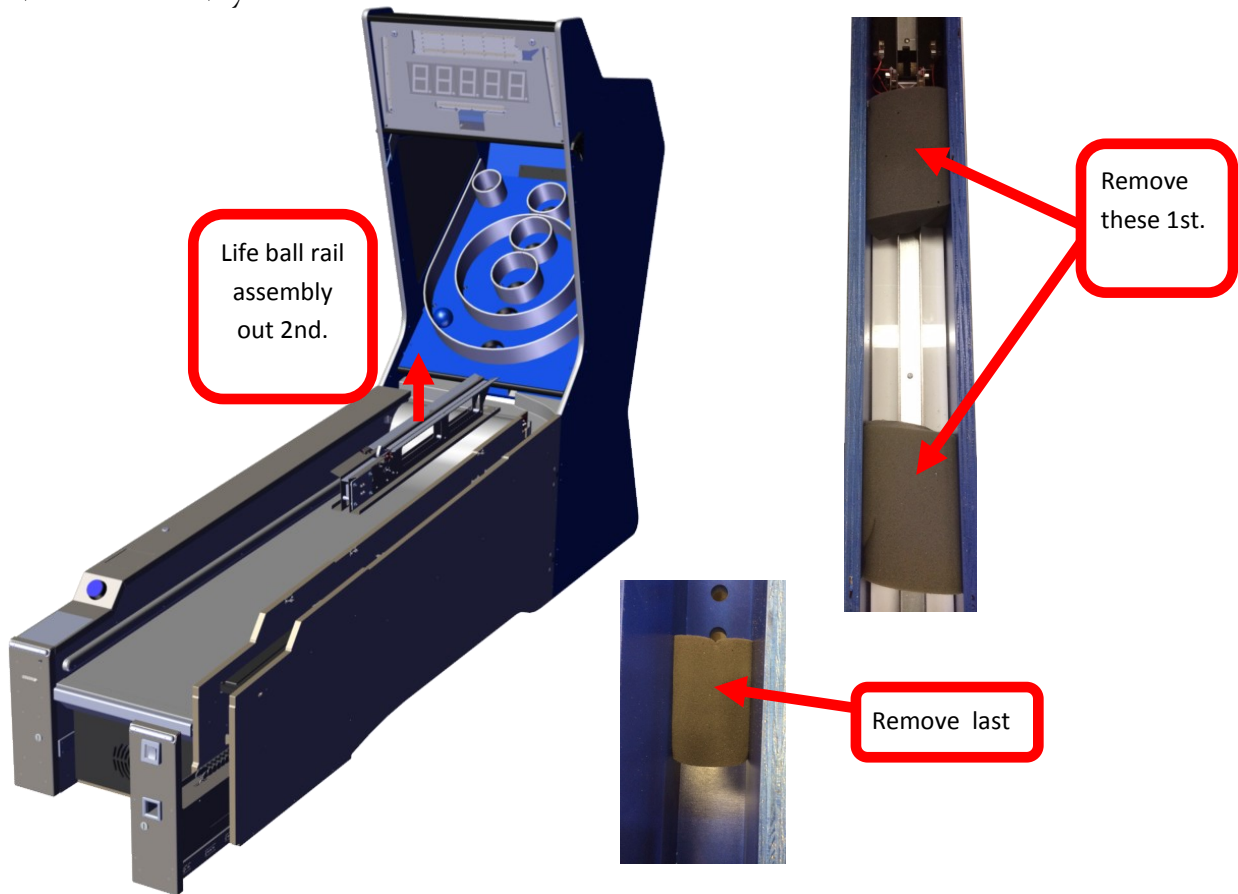

## STEP 7:

Unlock both top locks, lift up, push the bottom in slightly, and lower the top down, unplug harness and lift out.

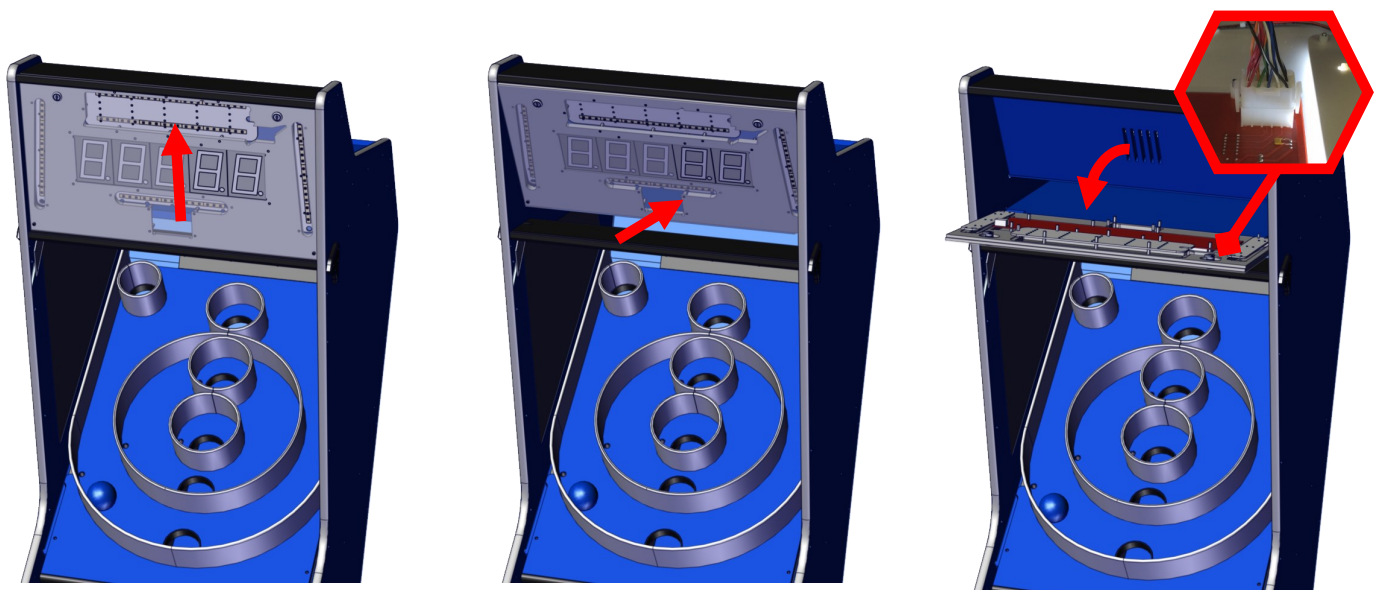

## Step 8:

Attach the right glass assembly around the side panel. The right glass assembly is marked “R” for right and “L” for left. Attach the glass assembly using hat nut on the outside and an Allen bolt on the inside. Run the LED harness through the side channels. Repeat for the left side.

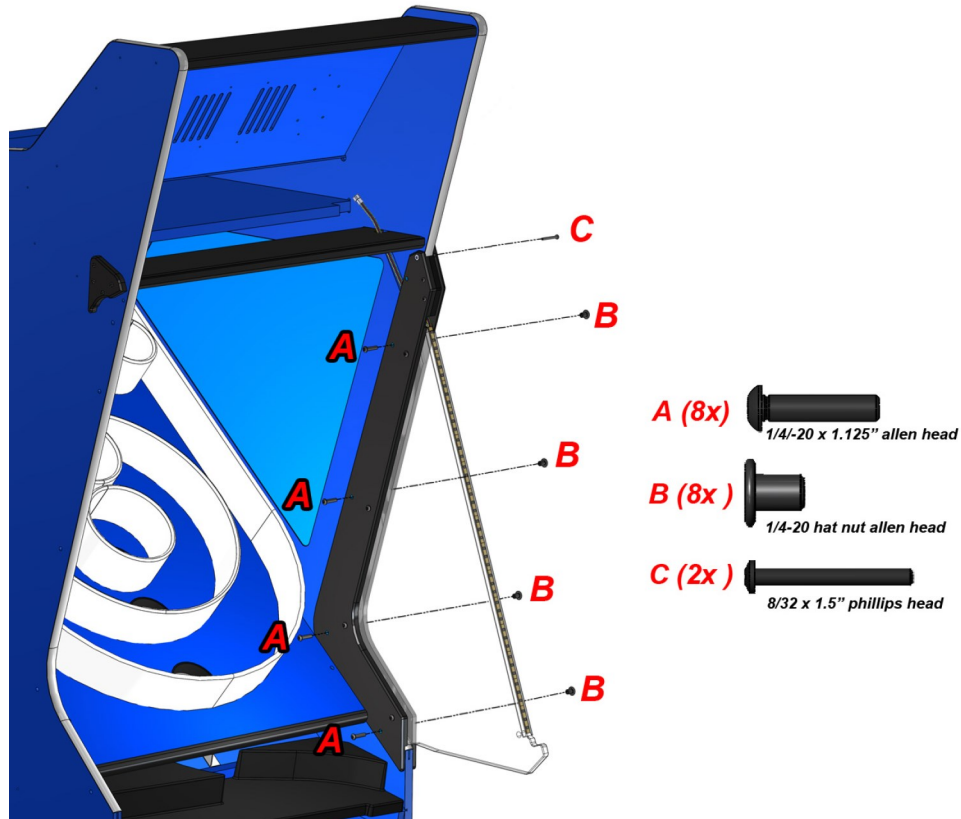

## Step 9:

Slide the playfield glass assembly wings through the outside top of the side glass assemblies. Attach a hat nut [B] to the outside and a bolt [D] on the inside. Attach the LED harness covers using the 1/2" 655 screws [E].

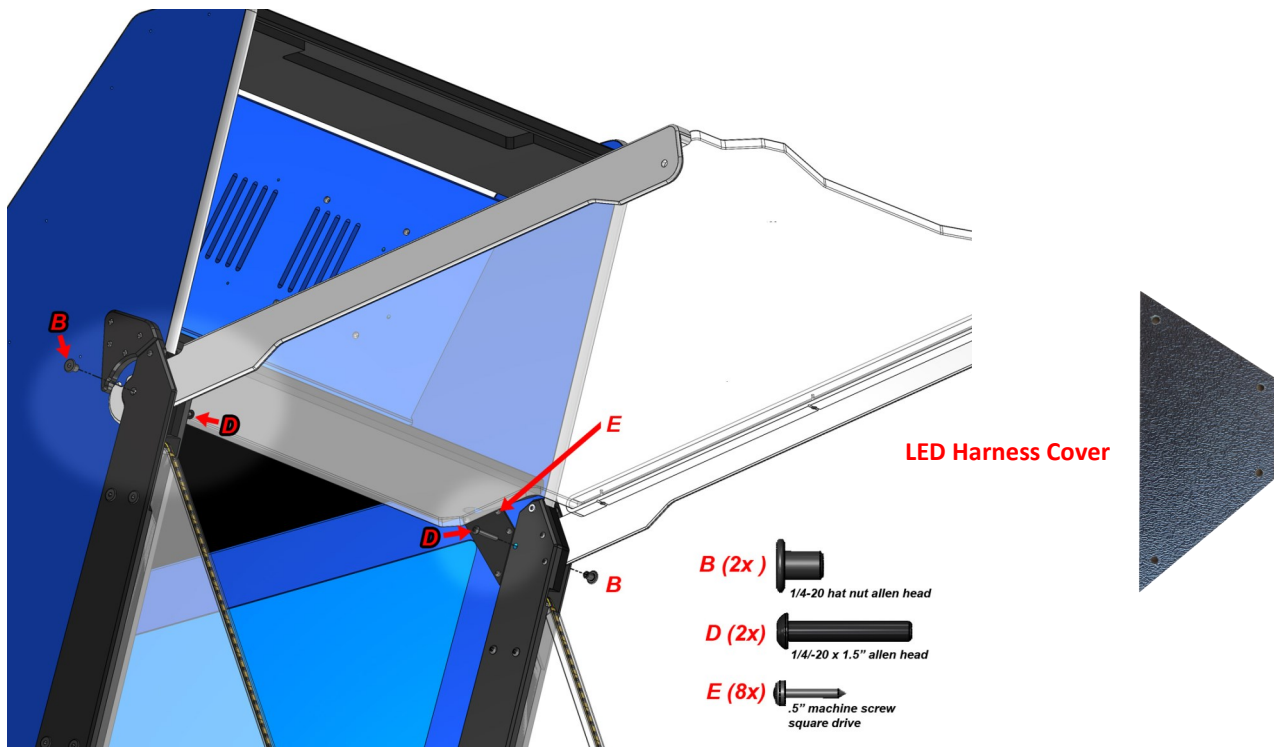



## STEP 10

Secure the Playfield cover glass using provided hat nuts and thumb screws. See below.

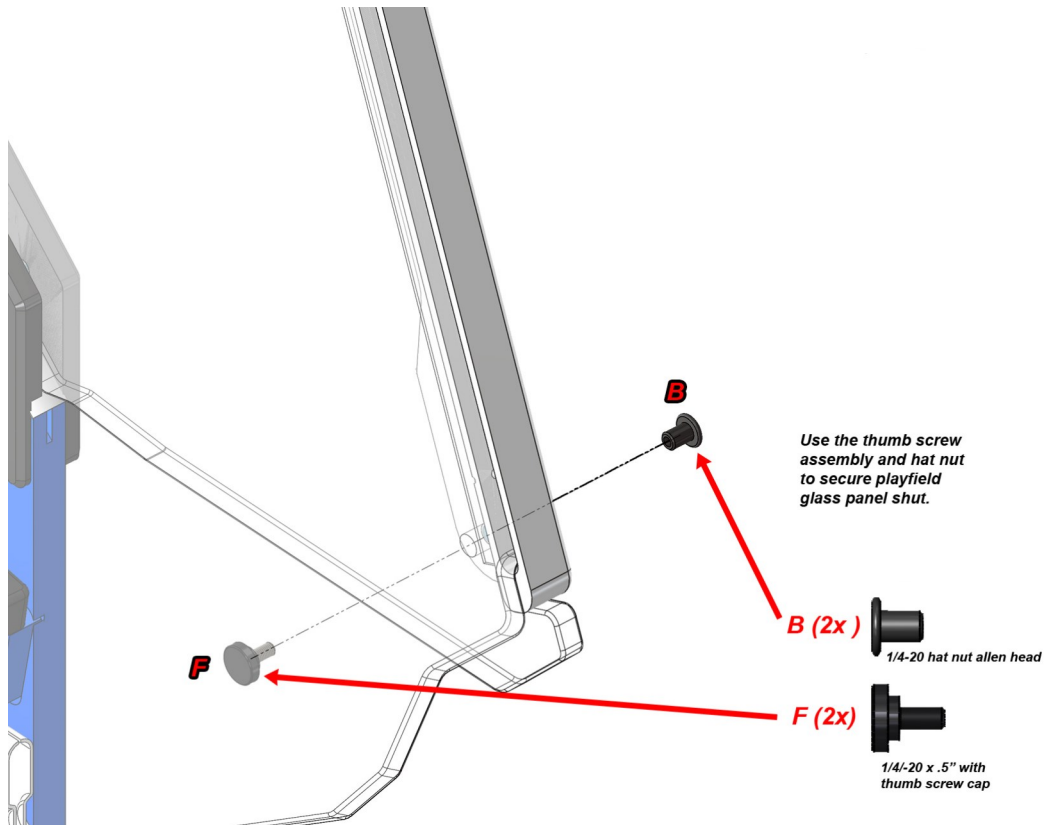

## STEP 11

Connect the LED harnesses on both sides.

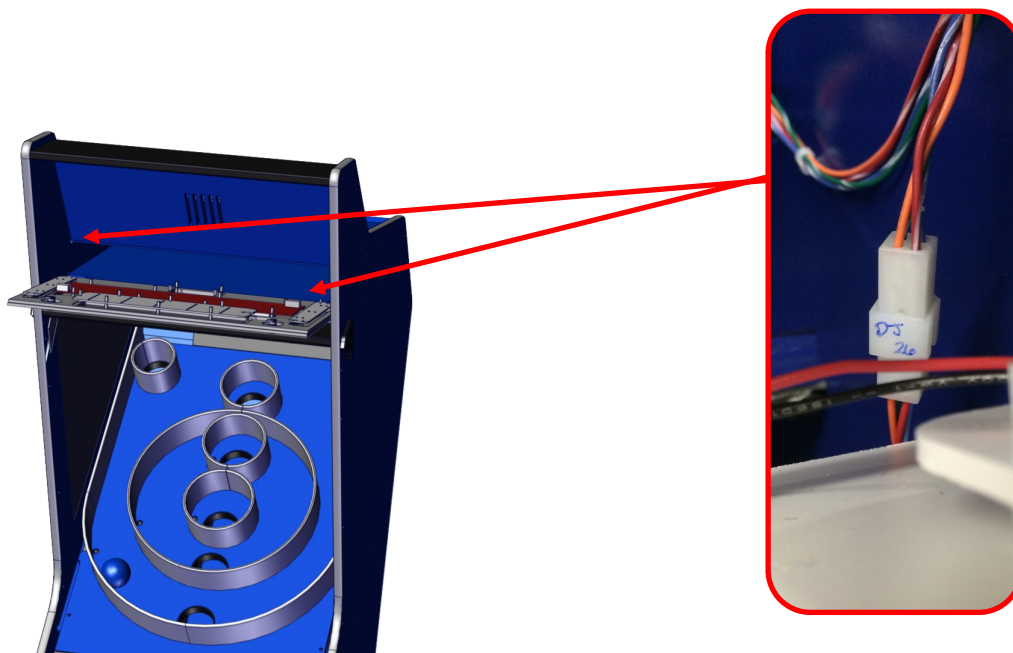

## STEP 12:

Lay the upper display assembly on its front and plug the harness back in. Tilt the bottom toward the back and then insert the top into the cabinet's upper groove. Slide the display down and relock the two locks.

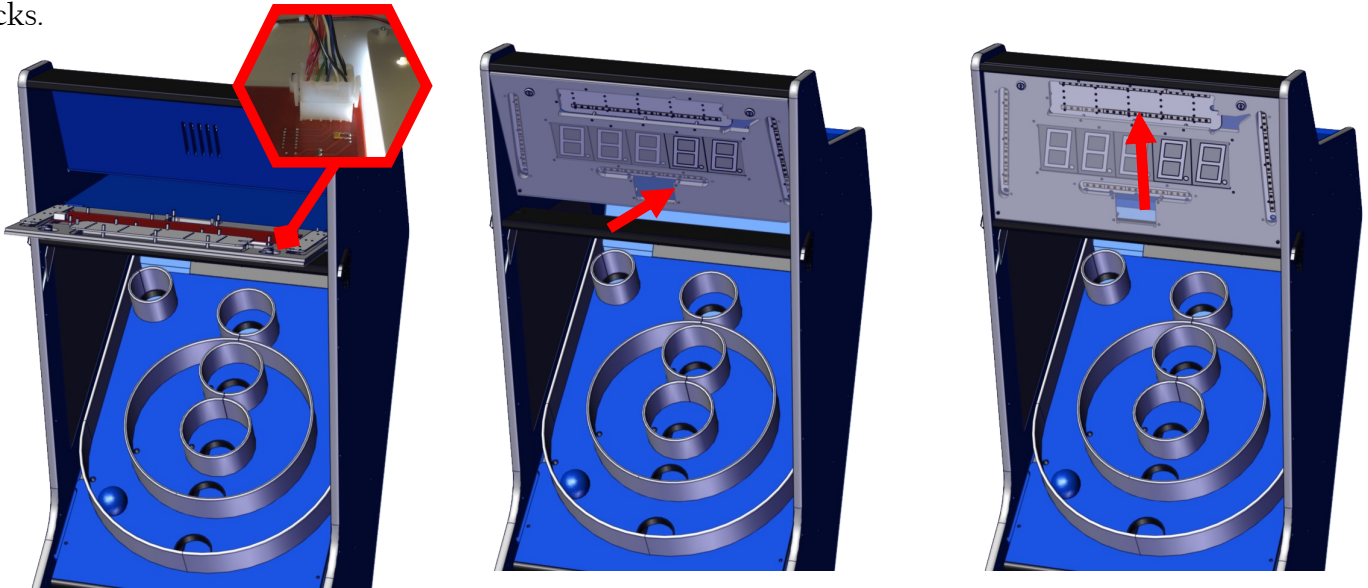

## FINAL STEP

Your game is now assembled. If you are planning on using more than one game then repeat the previous steps for each game. See the section “Linking Multiple Games” for instructions on how to link them together.

If you are using only one game at your location you will need to verify that the Station ID has been set to 1. Failure to do so will result in no LED lighting effects. Follow the below sub-steps to confirm. It is now time to program your game to your desired settings. See the section “Program Settings” for further information.

### Step A:

Unlock the lower front door and lower the door. Slightly reach in and pull the Main board assembly tray out.

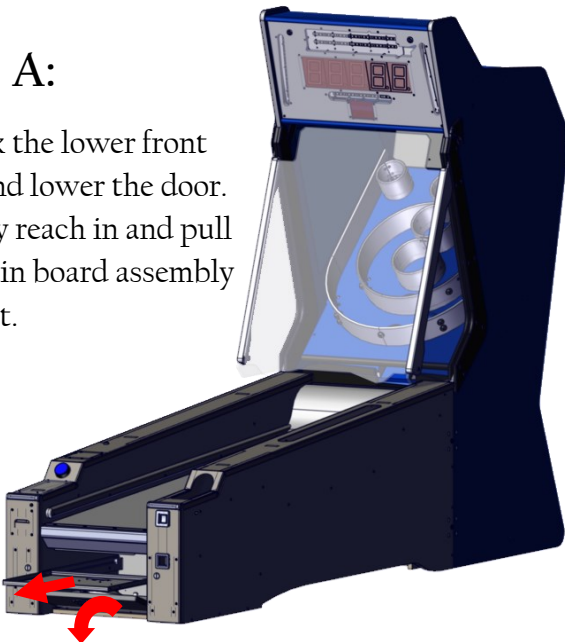

### Step B:

Locate the rotary dial switch labeled SW1 next to the phone linking connectors and turn the dial so that the black arrow is pointed to the position 1.

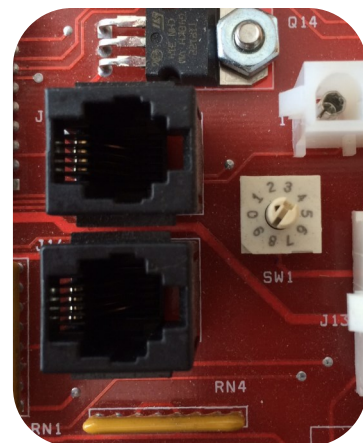

## Linking Multiple Games

Your ICEBALL FX alley roller game can be linked with other ICEBALL FX alley roller games. Up to nine games can be linked together. Each game must have its options set up the same. The linking of the games will only synchronize the LED lighting effects. A Mega Marquee is used to provide a Super Bonus which is set and controlled by the Mega Marquee.

To link your games together, each game must be set to a different ID number and must start at Station ID 1. Follow the next few steps to properly link your games together.

### STEP 1: Locate the Cabinet Spacer and mounting hardware

Each ICEBALL FX alley roller game shipped includes one cabinet spacer and its mounting hardware. Locate your cabinet spacer and six 1½" wood screws.

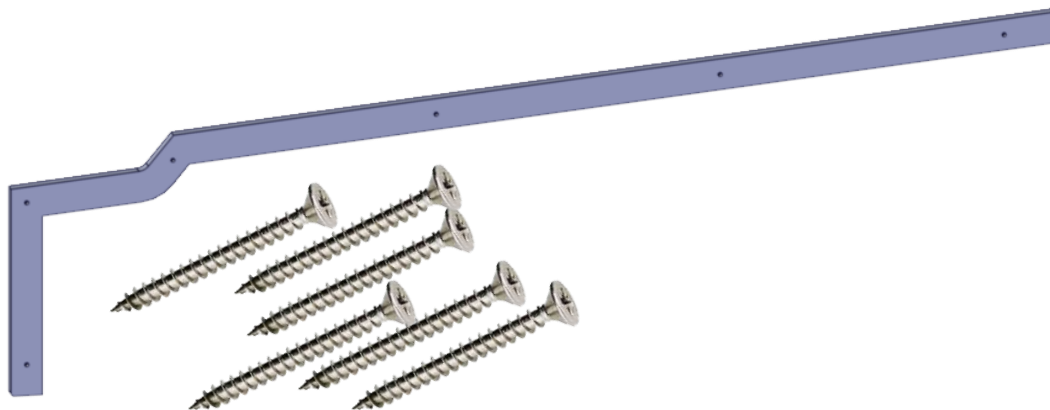

### STEP 2: Attach Cabinet Spacers

For each game that is placed side to side a Cabinet spacer is required between the two games. Position the Cabinet Spacer and attach to only one cabinet side using the six 1½" wood screws.

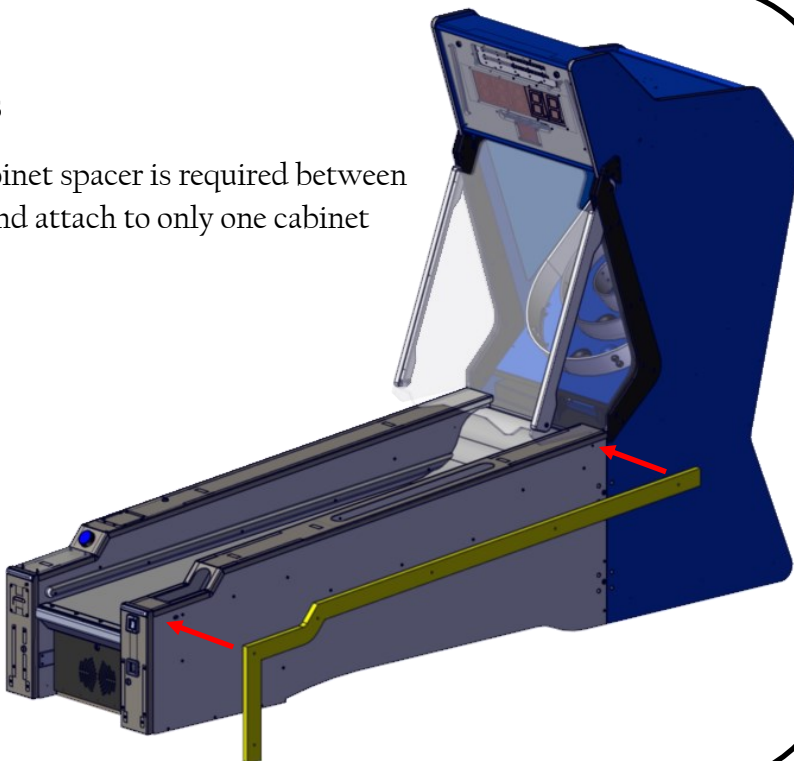

### STEP 3: Position

Slide the two games together as shown. If more games are desired to be linked, repeat step 2. Only install a Cabinet Spacer between games and not at the two ends. Use only one Cabinet Spacer between games.



### STEP 4: Phone cord linking cable

From the back of the game and using one supplied 14' phone cord per paired game, insert each end of the cord into the upper hole showed below.

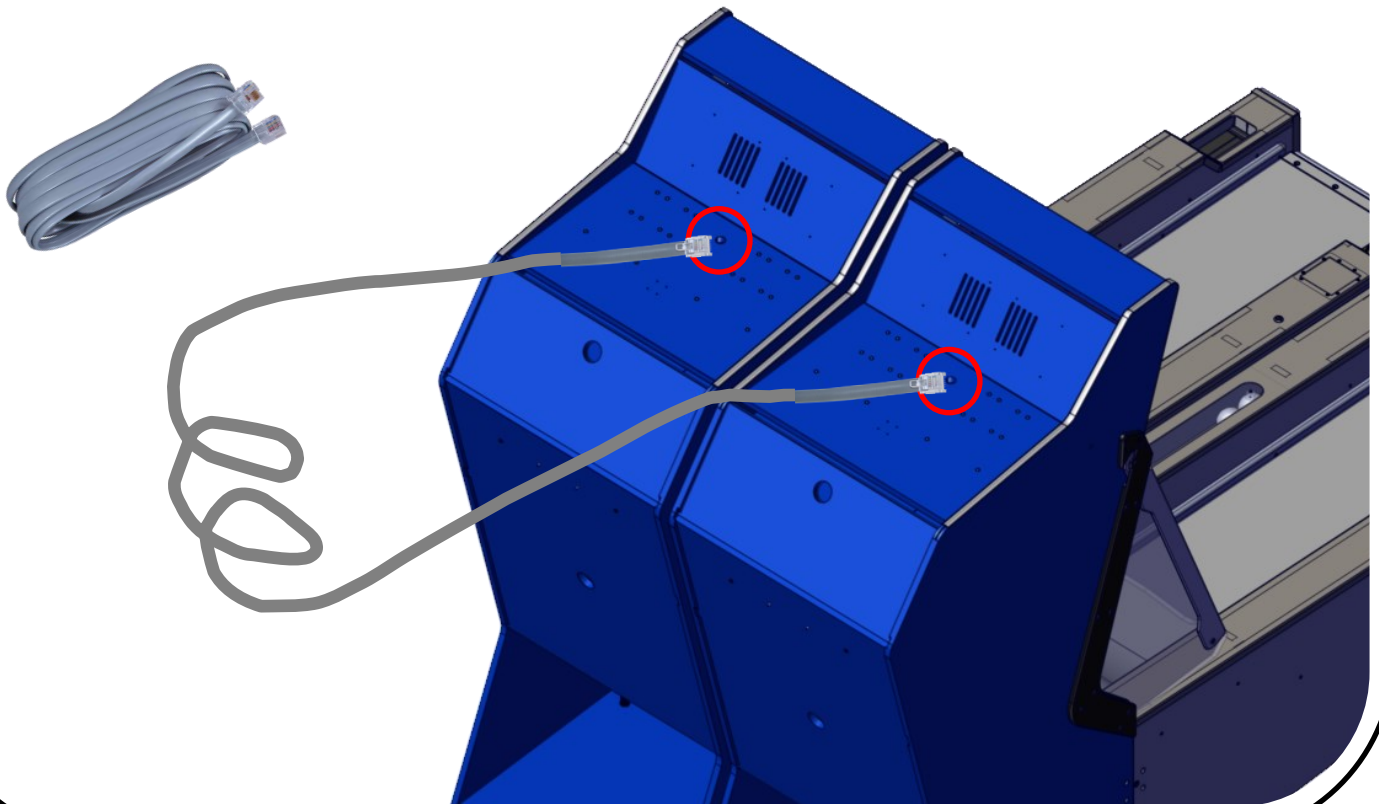

## STEP 5: RGB Board Connection

Open the upper Display as described in step 7 and connect the Linking Phone Cord to any connector not used. It makes no difference which Phone connector on the RGB LED board you use.

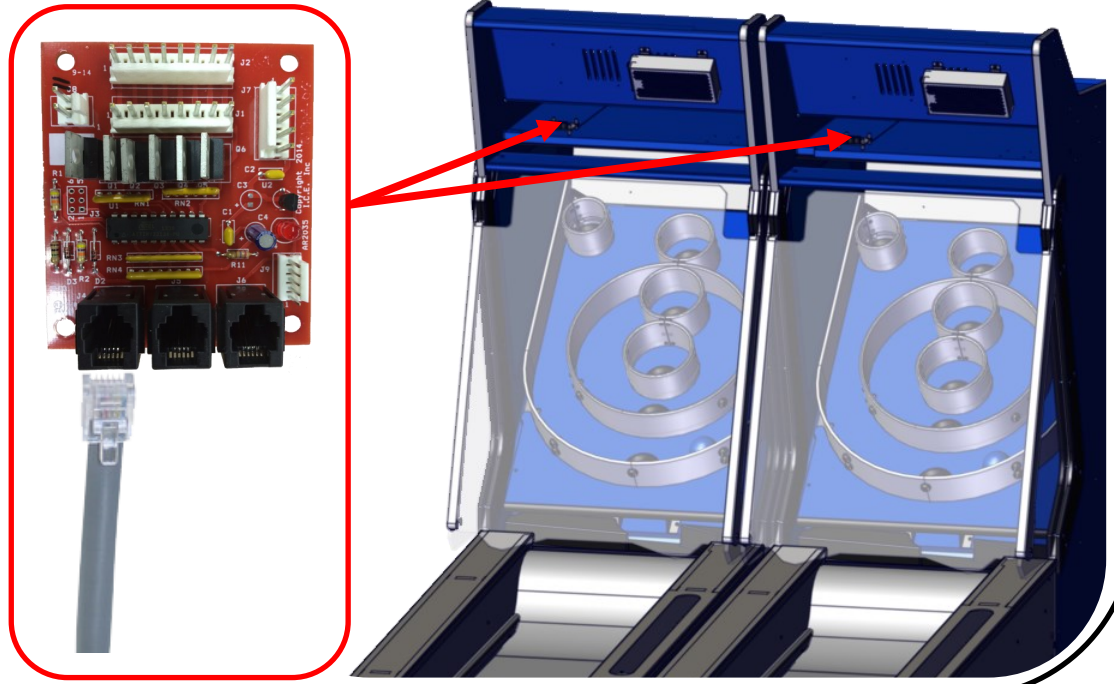

## Six Games Linked Example

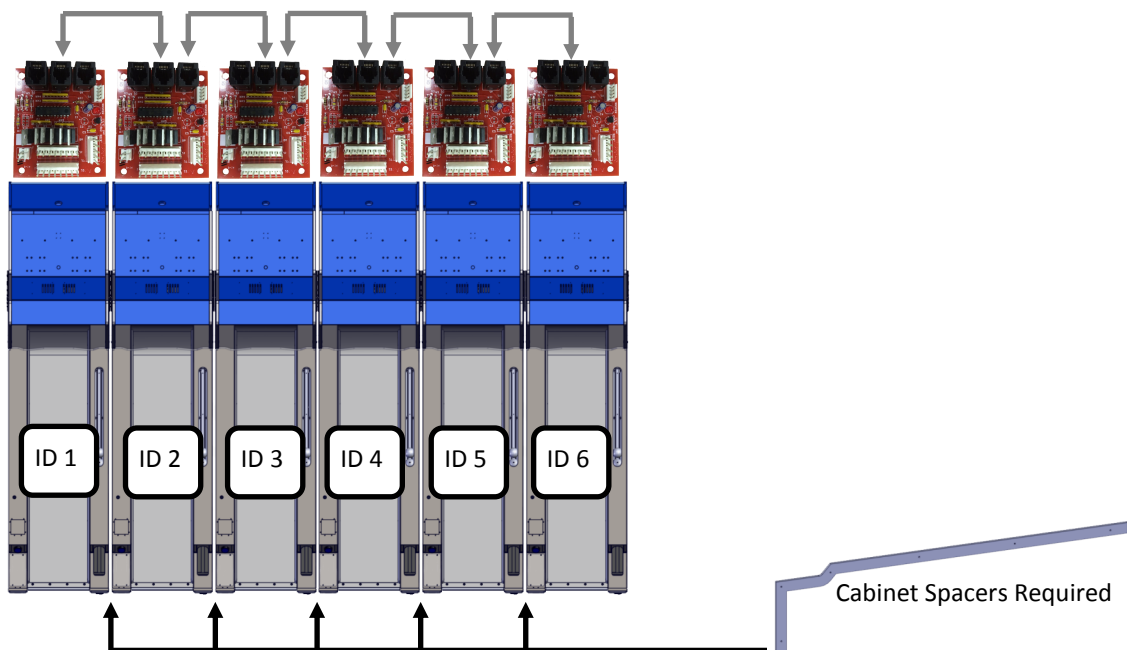

# Mega Bonus Marquee Install

The Mega Bonus Marquee can be mounted either between two games or three. It is recommended to mount the Mega Bonus Marquee centered to the games. So if an even number of games are being used, you would install the Mega Bonus Marquee between two games. If an odd number of games are being used, you would install the Mega Bonus Marquee between three games. For example if you had four games and installed the Mega Bonus Marquee you would install the marquee between games two and three. If you had five games and installed the Mega Marquee you would install the marquee between games two and four.



Attach the Mega Bonus Marquee using the supplied hardware as shown.

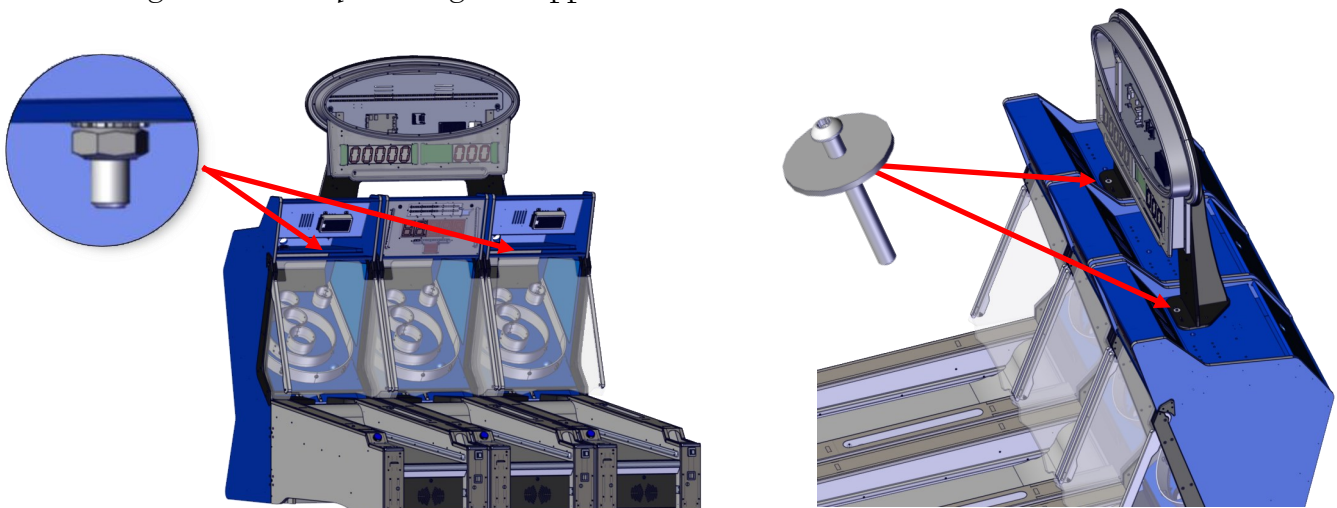

Plug both the AC cord and Phone Linking Cable into the back of the Mega Bonus Marquee.

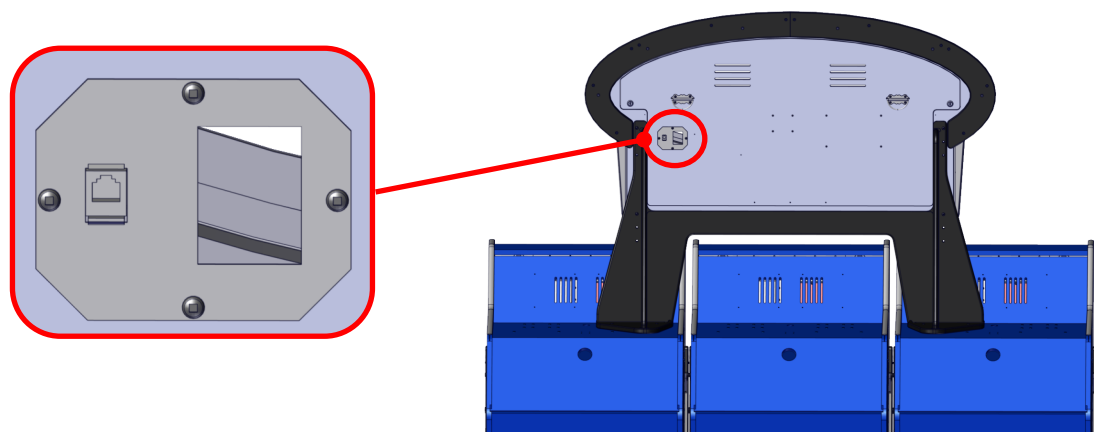

Open the upper Display as described in step 7 and connect the Mega Bonus Linking Phone Cord to any connector not used. It makes no difference which Phone connector on the RGB LED board you use.

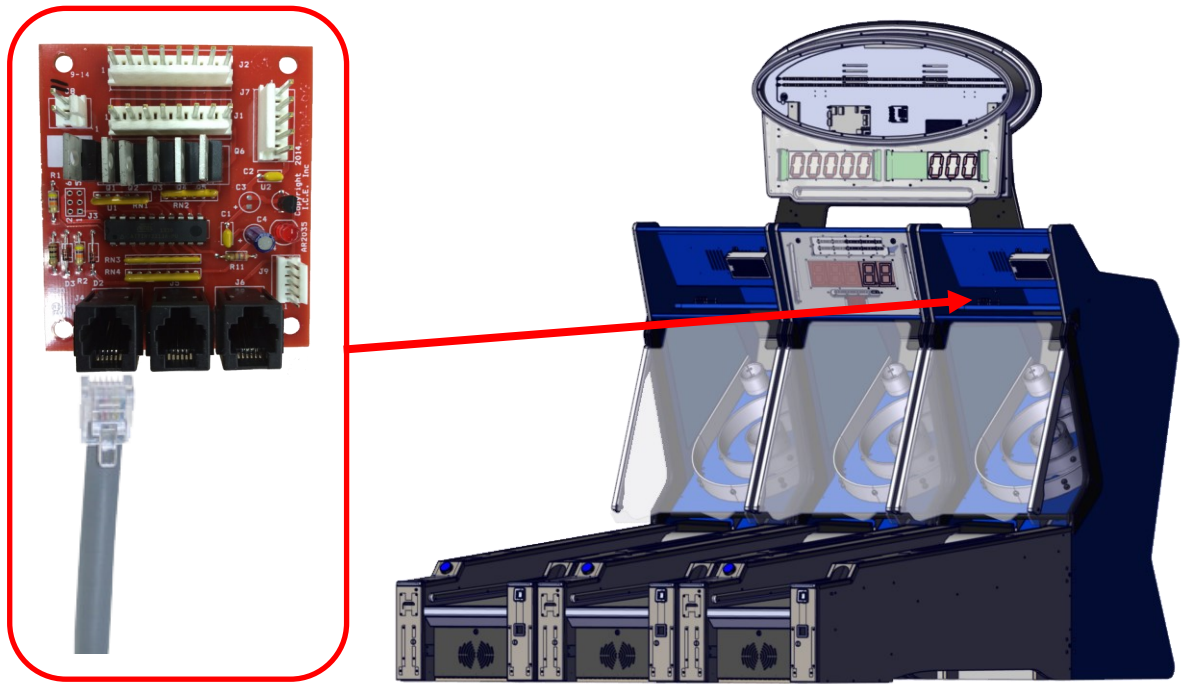

## Mega Bonus Marquee Programming

The Mega Bonus Marquee can be programmed remotely by any game linked as long as each game has been set to a different Station ID number and only during the power on sequence. When the games and the Mega Bonus Marquee are powered on the Marquee will display the revision of it's software and then show a default score. Before the Marquee displays the default score press the "Program" button. When the marquee has entered programming mode it will display dashes in the score display and a count down will begin in the balls display. You will have approximately 20 seconds to make your changes. Holding the appropriate keys down will advance the tickets or the score without needing to press multiple times.

When the time expires the game will enter game mode. To continue to program the marquee you need to power off the game and repeat the above procedures. However entering game programming and exiting will simulate a power cycle and you can again enter marquee programming during the display of the revision number.

Below are the buttons and their functions:

Button	Function
Program	Score Up
Select	Score Down
Up	Tickets Up
Down	Tickets Down

To enter program mode for the game, press the “program” button during attract mode. Pressing the “program” button during game play will be ignored. To cycle through the different options use the “select” button and to change the values of the options use the “advance” button. Exit programming by pressing the “program” button.

Located on the main board are push buttons labeled SW2, SW3, SW4, SW5, and SW6. SW2 switch is the Program button. SW3 switch is the Select button and SW4 switch is the Advance button.

Option	Default	Min	Max	Inc		
0	Game Volume	3	0	7	1	Game Volume
1	Coin I	2	0	9	1	Cost of Game
2	Discount	0	0	9	1	# of Games til Disc
3	Games Per Credit	1	1	9	1	# of Games Added per Credit
4	Attract Time	0	0	30	1	Attract time in minutes
5	Slot 0-9K	1	0	25	1	Tickets for Slot
6	Slot 10K-14K	5	0	25	1	Tickets for Slot
7	Slot 15K-19K	10	0	50	1	Tickets for Slot
8	Slot 20K-24K	15	0	50	1	Tickets for Slot
9	Slot 25K-29K	20	0	50	1	Tickets for Slot
10	Slot 30K-34K	25	5	100	5	Tickets for Slot
11	Slot 35K-39K	30	5	100	5	Tickets for Slot
12	Slot 40K-44K	40	10	100	10	Tickets for Slot
13	Slot 45K-49K	50	10	100	10	Tickets for Slot
14	Slot 50K-59K	75	25	250	25	Tickets for Slot
15	Slot 60K-69K	100	25	250	25	Tickets for Slot
16	Slot 70K-79K	150	50	500	50	Tickets for Slot
17	Slot 80K-89K	200	50	500	50	Tickets for Slot
18	Slot 90K	500	100	1000	50	Tickets for Slot
19	JFP Tickets	0	0	20	1	If not zero, ONLY these tickets paid overrides slots
20	Ticket Cap	0	0	50	1	Max Tickets Given per game, 0 = off
21	Ticket Multiplier	1	1	2	1	Virtual tickets per dispensed ticket
22	Theme On	1	0	1	1	Whenever music Plays 0 = Off, 1= on
23	Factory Reset	0	0	1	1	Factory Reset



## ERROR Codes

Error Number	Description
1	Bad or missing Compact Flash Card
2	Zero Count Sensor Error - Check for Balls in Sensor
3	Sensor 1K
4	Sensor 2K
5	Sensor 3K
6	Sensor 4K
7	Sensor Left 10K
8	Sensor Right 10K
9	Ball Count Sensor Error
10	Coin 1 Stuck Down
12	Ticket Error

If the solenoid will not fire because the zero count sensor is blocked than the decimal point in the left balls digit will light indicating the reason for the solenoid to not open.

If the game is out of tickets, then "tic" will be displayed on the score until the tickets have been reloaded and paying out. Should a player insert money then the game will continue as normal until the end of the game where the out of tickets display will be redisplayed.

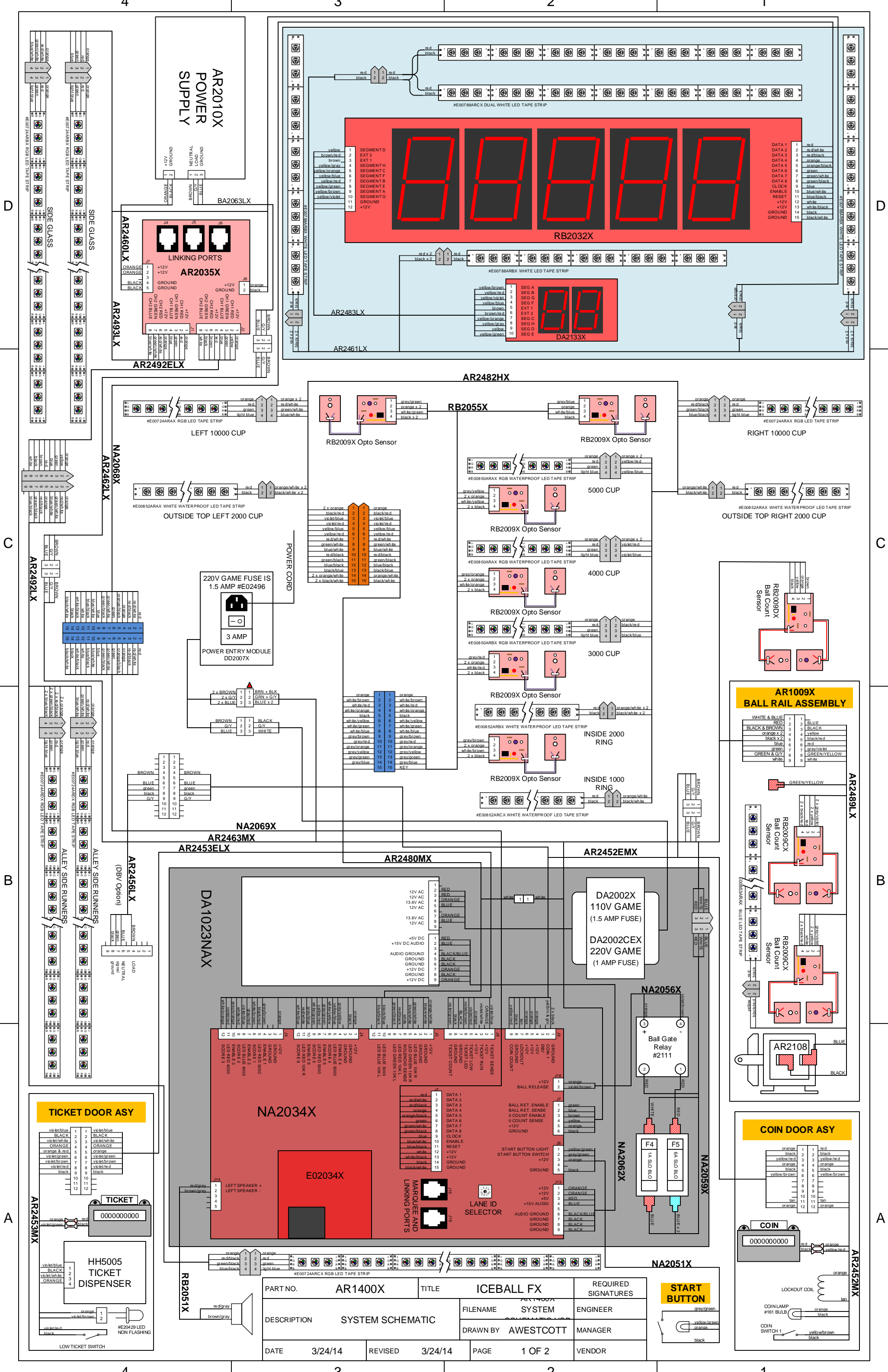

PART NO.	AR1400X	TITLE	ICEBALL FX	REQUIRED SIGNATURES
DESCRIPTION	SYSTEM SCHEMATIC	FILENAME	SYSTEM	ENGINEER
DATE	3/24/14	DRAWN BY	AWESTCOTT	MANAGER
REVISED	3/24/14	PAGE	1 OF 2	VENDOR

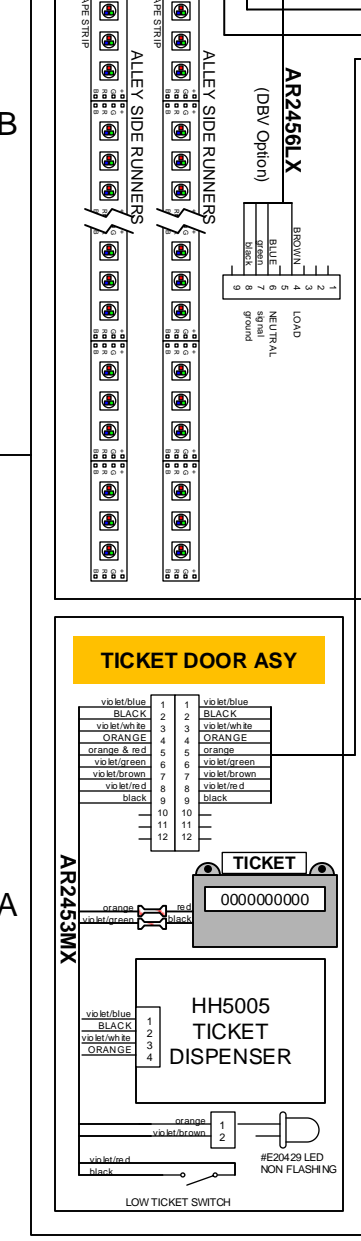
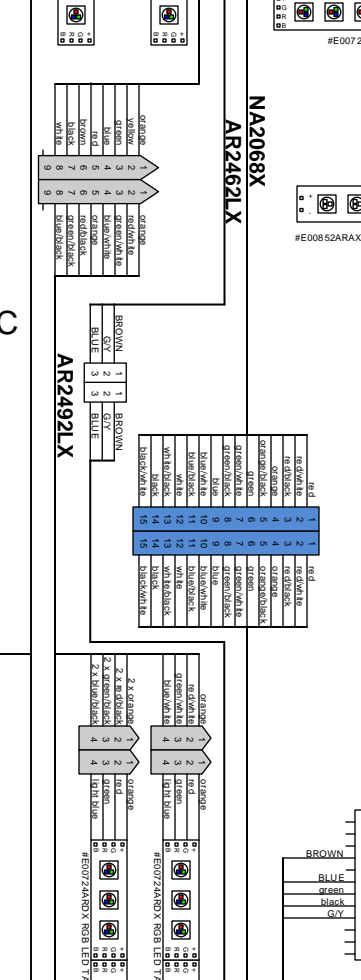
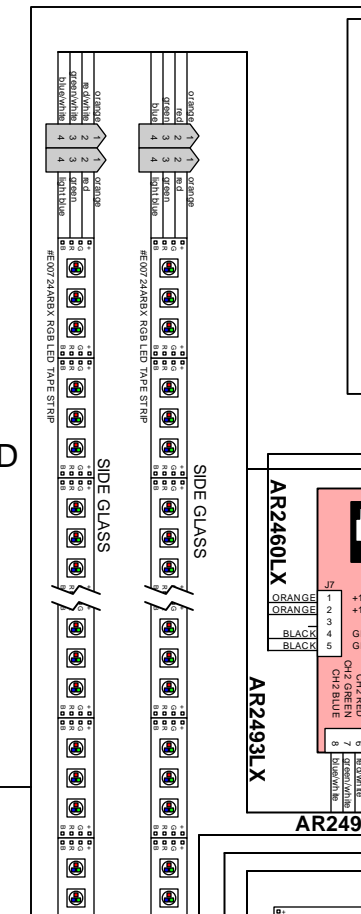
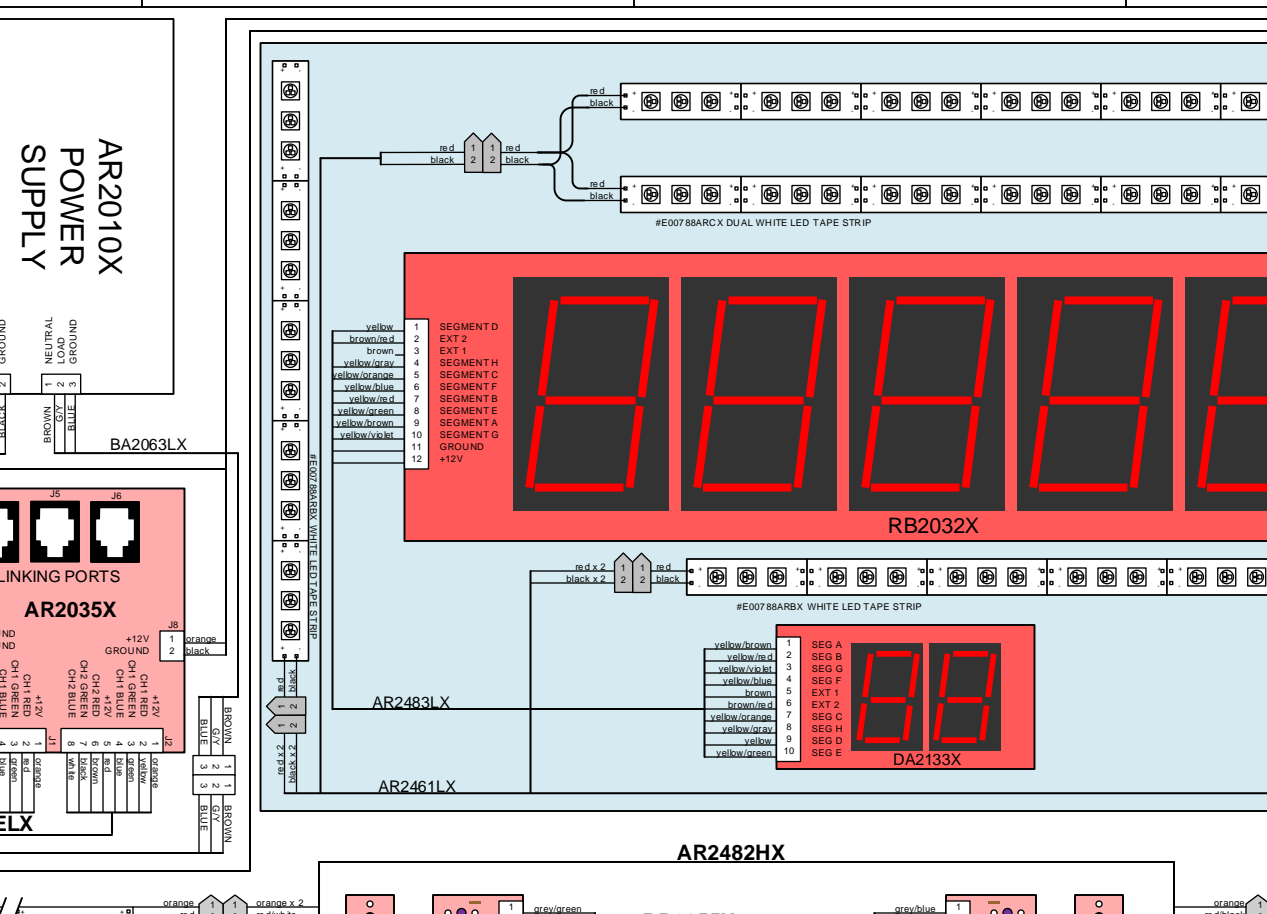
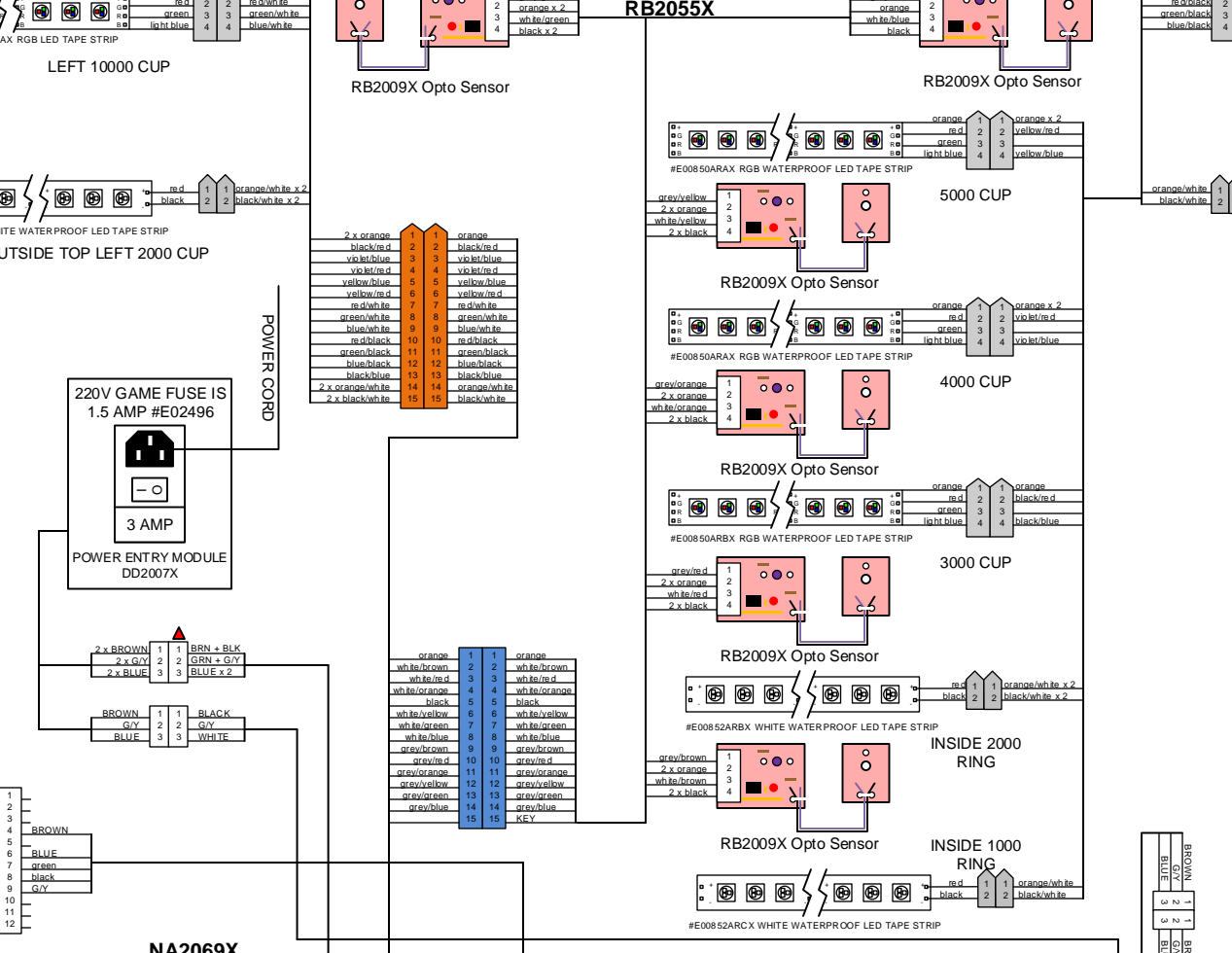
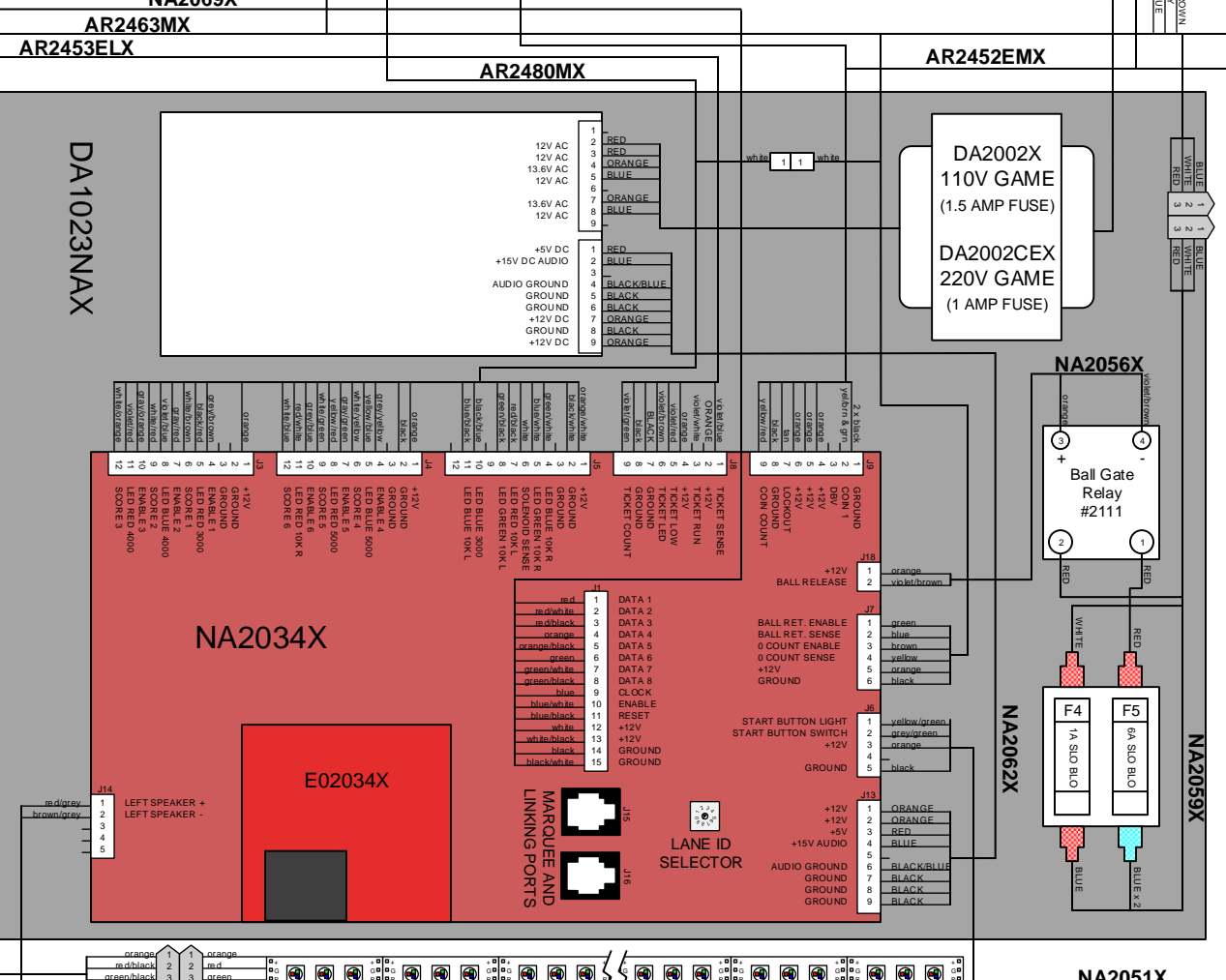
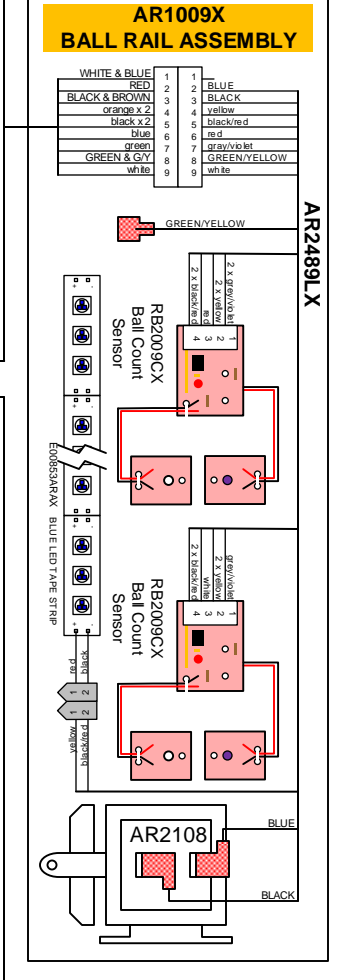
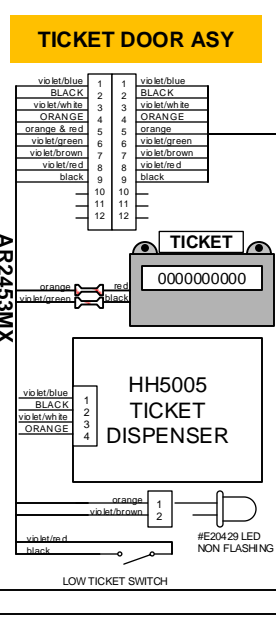
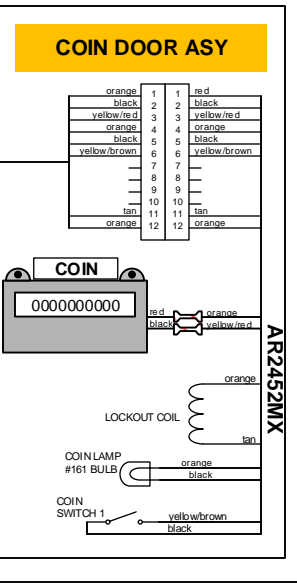
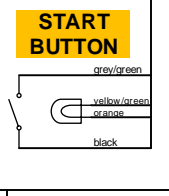



# WARRANTY POLICY

I.C.E. Inc warrants all components in new machines to be free of defects in materials and workmanship for the period listed below:

- 180 days on Main PCB's, Computers & Motors
- 1 year on all LCD monitor panels
- 90 days on all other electronic and mechanical components
- 30 days on all I.C.E. repairs and parts purchases

I.C.E. Inc shall not be obligated to furnish a warranty request under the following conditions:

- Equipment or parts have failed through normal wear and tear
- Equipment has been subjected to unwarranted stress, abuse or neglect
- Equipment has been damaged as a result of arbitrary repair/modification

Products will only be covered under warranty by obtaining an I.C.E. authorized RMA #. To obtain an RMA # please provide I.C.E. tech support with the game serial # or original I.C.E. invoice # and a detailed description of the failure or fault symptoms.

I.C.E. Inc will assume no liability whatsoever for costs associated with labor or travel time to replace defective parts. All defective warranty covered components will be replaced with new or factory refurbished components equal to OEM specifications.

I.C.E. Inc will cover domestic UPS ground, or comparable shipping costs during the warranty period. International or expedited shipments are available for an additional charge. To obtain credit defective parts must be returned to I.C.E. Inc, at the customer's expense, within 30 days. After 30 days a 15% re-stocking fee will apply to all returns.

ICE distributors are independent, privately owned and operated. In their judgment, they may sell parts and/or accessories other than those manufactured by I.C.E. Inc. We cannot be responsible for the quality, suitability or safety of any non-I.C.E. part or modification (including labor) that is performed by such a distributor.

Innovative Concepts in Entertainment

**10123 Main St.**

**Clarence, NY 14031**

**Phone #: (716) - 759 – 0360**

**Fax #: (716) – 759 – 0884**

**[www.icegame.com](http://www.icegame.com)**