

ASPHALT LEGENDS ARCADE 5

OWNER'S MANUAL

Ver.2.07



! WARNING

- For safety reasons, please read the manual first before plugging in machine.
- Please keep this manual properly for convenient reference as needed.
- The machine specifications or the information in this operation manual may be change without prior notice.

About This Manual

Thank you for purchasing this product.

The manual describes how to install, set up, use and maintain the product. The main purpose of the manual is to instruct how to operate the product correctly and safely. Please follow all the safety and warning instructions in the manual to avoid personal injury and product damage.

This product may only be maintained by a technician. A technician mainly refers to a person who has obtained a certificate of senior middle school related to mechanical engineering, electrical engineering or at a level equal to that of technical senior middle school graduates, and is engaged routinely in the maintenance, management, repair of amusement machine.

When transferring the ownership of this product, be sure to provide this manual with the machine.

For further information about the game and repair (including consumables), please contact our company.

© GuangZhou Wahlap Technology Corporation Limited All Rights Reserved.

Unauthorized reproduction of this document or any of its contents in any form is strictly forbidden.

Table of Contents

About This Manual

1. Safety Precautions.	1
1.1 Warning Stickers	1
1.2 Placing Site	1
1.3 Safety Precautions	2
1.4 Precaution during Play	3
1.5 Transporting and Moving	3
1.6 Installing and Placing	4
1.7 Caution & Warning Stickers	5
2. Product Description.	6
2.1 Product Specification	6
2.2 Overview	7
2.3 Parts Name	8
2.4 Shipment List	9
2.5 Packing List	12
2.6 Install Direction	13
2.7 Position of seat rear-plastic components	17
3. Game Description.	18
3.1 Appearance Design	18
3.2 Game introduction	18
3.3 How to play	18
4. Test and Setting.	19
4.1 Game Description	19
4.2 Installation	19
4.2.1 Connection Setting	19
4.2.2 I/O Adjustment	20
4.2.3 Setting Other Related Items	20
4.2.4 Important Notes for Staff	20
4.3 How to Play	22
4.3.1 Linking & Networking for Cabinets Information	24
4.4 Instruction Of The Game Display	25
4.5 Using the Operator Settings	26
4.5.1 Menu Structure	26
4.5.2 Main Menu Operation	27
4.5.3 Hardware Test	28
4.5.3.1 I/O Test	29
4.5.3.2 Screen Test	30
4.5.3.3 Sound Test	31
4.5.3.4 Lamp Test	32
4.5.3.5 Connection Test	33
4.5.3.6 Counter Test	35
4.5.3.7 Vibration Test	36

4.5.3.8 Fan Speed Test	37
4.5.3.9 Air Spring Test	38
4.5.3.10 Drain Valve Test	39
4.5.3.11 Camera Test	40
4.5.3.12 Force Feedback Test	41
4.6 System Setting	42
4.6.1 Time Settings	43
4.6.2 Connection Setting	44
4.6.3 Country Setting	45
4.6.4 Store Setting	46
4.6.5 Password Setting	47
4.6.6 I/O Adjustment	48
4.6.7 Air Spring Adjustment	49
4.6.8 Seatbelt Setting	50
4.7 Game Setting	51
4.7.1 Coin Option	52
4.7.2 Volume Setting	53
4.7.3 Game Time	54
4.7.4 Battle Reward Setting	55
4.7.5 Flow Time Setting	56
4.7.6 Create Account For A Free Game	57
4.8 Income Data	58
4.8.1 Daily Income	59
4.8.2 Monthly Income	60
4.8.3 Total Report	61
4.9 System Reset	62
4.9.1 Reset Income Data	63
4.9.2 Restore Default Setting	64
4.9.3 Ranking Board Reset	65
4.9.4 Update Progress	66
4.10 Game Setting Defaults	67
5. Maintenance and Service	68
5.1 Maintenance and service	68
5.2 Part Replacement	69
5.2.1 Repair and replacement of coin box and the light bar of cashbox	69
5.2.2 Repair and replacement of light bar for exhaust tube and 5050 soft strip light ...	70
5.2.3 Maintenance and replacement of (film) switch buttons and light board (LED) of button ...	71
5.2.4 Repair and replacement for I/O control panel and motor control panel	72
5.2.5 Maintenance and replacement of woofer	72
5.2.6 Maintenance and replacement of 5050 soft strip light (L=800mm) and 5050 soft strip light (LPD6803 chip) ...	73
5.2.7 Repair and replacement of 5050 soft strip light and LCD	74
5.2.8 Maintenance and replacement of main machine	75
5.2.9 Maintenance and replacement of air compressor	75
5.2.10 Maintenance and replacement of filters and fluid control valves	76
5.2.11 Repair and replace the power box and solenoid valve	77
5.2.12 Maintenance and replacement of control panel of air compressor system, and light control pane ...	78

5.3 Air Compressor Maintenance	79
6. Assembly	81
6.1 Assembly tree diagram.....	81
6.2 General assembly of machine(A9DX-0000000)	82
6.3 Screen frame assembly (A9DX-0100000)	84
6.3.1 Frame base assembly (A9DX-0101000)	86
6.3.2 Filter assembly I(A9DX-0102000)	88
6.3.3 Filter assembly(A9DX-0103000).....	89
6.3.4 Fluid control valve assembly(A9DX-0104000).....	90
6.3.5 Main machine assembly(A9DX-0105000).....	91
6.3.5.1 A9DX main machine(A9DX-0105000A)	92
6.3.6 Power amplifier assembly(A9DX-0106000).....	93
6.3.7 Power box transformer assembly(A9DX-0107000).....	94
6.3.8 Vibration power amplifier board assembly(A9DX-0108000)	95
6.3.9 Motor drive plate assembly (A9DX-0109000).....	96
6.3.10 Power-in assembly (A9DX-0110000).....	97
6.3.11 Air compressor assembly(A9DX-0111000)	98
6.3.12 Assembly of LCD(A9DX-0112000).....	99
6.3.13 Camera assembly(A9DX-0113000)	100
6.3.14 Light box & light bar assembly(A9DX-0114000).....	101
6.3.15 Filter assembly II(A9DX-0115000).....	102
6.4 Vivid platform assembly (A9DX-0200000)	103
6.4.1 Platform bottom assembly (A9DX-0201000)	104
6.4.2 Air bag assembly (A9DX-0202000)	105
6.4.3 Platform support frame assembly (A9DX-0203000)	106
6.4.4 Platform sensor assembly (A9DX-0204000).....	107
6.4.5 Base IO board assembly (A9DX-0205000).....	108
6.4.6 Solenoid valve base assembly (A9DX-0206000).....	109
6.4.7 Base power box assembly (A9DX-0207000).....	110
6.4.8 Platform gate (A9DX-0208000).....	111
6.5 Console assembly(A9DX-0300000)	112
6.5.1 Console speaker assembly(A9DX-0301000)	114
6.5.2 Steering wheel motor assembly(A9DX-0302000)	115
6.5.3 Console woofer assembly(A9DX-0303000).....	116
6.5.4 Blower assembly for console (A9DX-0304000).....	117
6.5.5 Console IO board assembly(A9DX-0305000)	118
6.5.6 Motor control panel assembly(A9DX-0306000)	119
6.5.7 Plastic-forming console assembly(A9DX-0307000)	120
6.5.8 Steering wheel assembly(A9DX-0308000).....	121
6.6 Car body assembly(A9DX-0400000)	122
6.6.1 Buckle-up assembly(A9DX-0401000).....	124
6.6.2 Buckle-up assembly(A9DX-0402000)	125
6.6.3 Safety belt assembly(A9DX-0403000).....	126

6.6.4 License plate light assembly(A9DX-0404000).....	127
6.6.5 Internal assembly of wheel(A9DX-0405000).....	128
6.6.6 External contour assembly(A9DX-0406000).....	129
6.6.7 Seat assembly(A9DX-0407000).....	130
6.6.8 Nitrogen cylinder assembly(A9DX-0408000).....	131
6.6.9 Long slide-rail group(A9DX-0409000).....	132
6.7 Platform pedal assembly(A9DX-0500000).....	133
6.8 Cashbox assembly(A9DX-0600000).....	134
6.8.1 Cashbox & light bar assembl(A9DX-0601000).....	135
6.9 Top light box assembly(A9DX-0700000).....	136
6.9.1 Light assembly on the right side of light box(A9DX-0701000).....	137
6.9.2 Light assembly on the left side of the light box(A9DX-0702000).....	138
6.10 Maintenance door assembly(A9DX-0800000).....	139
7.Printing Pattern	140
8.Wiring Diagram	142
After-sales Service	

1. Safety Precautions

1.1 Warning Stickers

In order to avoid injury to related people and damage to property, please observe the followings:

PLEASE READ FIRST

- The following marks can be used to indicate the magnitudes of risk and damage caused by ignorance or improper operation:



means “may result in serious injury or death”



means “may result in minor injury or property damage”

Serious Injury: refers to the situations in which hospital treatment or long-term treatment will be accepted because of losing sight, getting hurt, getting burnt, electric shock, fracture or intoxication.

Minor Injury: refers to the cases that there is no need to go to hospital or accept long-term treatment.

Property Damage: refers to the damage of house, facility, or hurt of livestock and pet

1.2 Placing Site

Warning

- please make sure the place line has been grounded before product installation, setup, testing, operation or repair
- This machine is designed for indoor use only. Never install the machine outdoors. Meanwhile, please avoid the following locations indoor:
 - Direct sunlight, water leakage, damp and high temperature places.
 - Near Flammable, volatile, or/and dangerous substance.
 - Slope, unstable places or locations subject to frequent vibration.
 - Near emergency exit, fire extinguisher or similar equipment.
- The rear part has the vent for heat emission from PC or screen. Don't place anything nearby to avoid game failure.
- Provide a space of minimum 30cm between the rear of the machine and the wall for good ventilation and heat emission

1.3 Safety Precautions

The owner shall pay attention to the followings when placing, checking and repairing machine to insure player's security and avoid damage:

Warning

- please check the voltage is 110V or 220V before the machine connects to the power supply, or it may cause a fire or electric shock.
- Make sure to plug the game into 110V or 220V main outlet to avoid fire and electric shock.
- Make sure to turn off the power when performing maintenance and service to avoid electric shock or short circuit.
- Do not unplug or plug the plug instantly.
- Don't touch the power plug with a wet hand to avoid electric shock.
- Don't expose the power cord/grounding line on the passageway. Failure to do this will damage the power cord, causing electric shock or short circuit.
- Don't lay anything near the power cord to avoid fire.
- Do not pull the power cord when unplugging, please hold the plug to avoid power cord damage, causing fire or electric shock.
- In case of power cord damage, please contact the local distributor for replacement
- Only use fuse and spare parts specified by our company
- Connect the connector firmly and tighten the screws.
- Do not dismount, replace or convert the product without our permission in order to avoid damage and human injury due to improper operation.
- Check and maintain the machine regularly.
- Keep "Warning stickers" clean and legible. Replace it immediately when the words are not legible or the dirt can't be removed.
- Please contact our service center when performing any work that is not described in this manual, and follow the instruction provided.

1.4 Precautions during Play

Caution

- In order to avoid injury and accident during play, the following people shall not play the game:
 - People who are injured or less mobile.
 - Person with poor health condition, such as hypertension or heart disease.
 - Person wearing high-heeled or slippery shoes.
 - Person who can't touch the pedal.
 - Pregnant woman, drunk people.
- When a player feels uncomfortable during play, remind the person to have a break, or stop playing.
- Make sure the player reads the warning labels and other indications, and plays in accordance with the instructions to avoid accidents such as electric shock and short circuit.
- Bystander shall not operate any button when the player is playing the game to avoid unnecessary trouble.

1.5 Transporting and moving

Caution

Transporting

- When transporting the machine with an elevator, be sure to employ "Lift Point" to prevent accident and damage to the machine.
- To prevent movement when transporting the machine on a vehicle, please fix the casters and fully retract the adjusters. Failure to do this may cause damage to the machine.
- When carrying the machine with a forklift, be sure to insert the fork to fork position and lift stably. If not, it may cause accident and damage to the machine.
- The glass and LCD screen are fragile. Avoid violent vibration or shock when transporting.

Moving

- Before moving the machine, unplug the power plug to prevent accident. Don't damage the cord.
- Pay attention to the obstructions and uneven surface when moving the machine to prevent accident and damage to the machine.
- Fully retract all adjusters before moving to prevent accident and hazard.
- Make sure to use at least two persons to conduct the above work to avoid accident and injury
- Pay attention to the moving direction, see fig.



1.6 Installing and Placing

Pay attention to the following when placing the machine.

Caution

- Place the machine on the flat and slip resistant area.
- Use the adjusters to fix the machine(See diagram 1)

- 1.loosen the nuts for the adjusters(clockwise),tighten the bolts with a wrench(clockwise).
- 2.Tighte the nut firmly(counter clockwise)and fix it well.

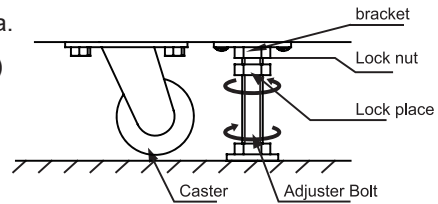

Diagram (1)

- In order to maintain good ventilation, heat dissipation and safety of the machine, please keep a distance of at least 30cm between the machine and the wall and its surroundings, and a distance of at least 80cm between the machine and the machine (as shown in Figures 2, 3 and 4).

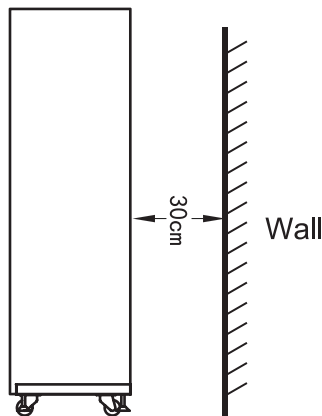

Diagram (2)

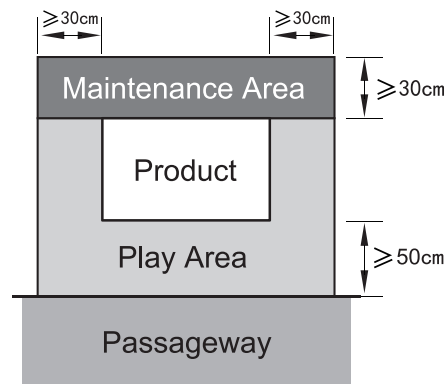
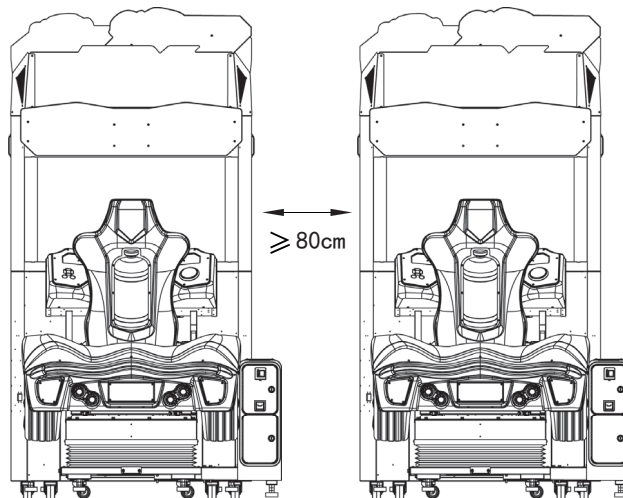
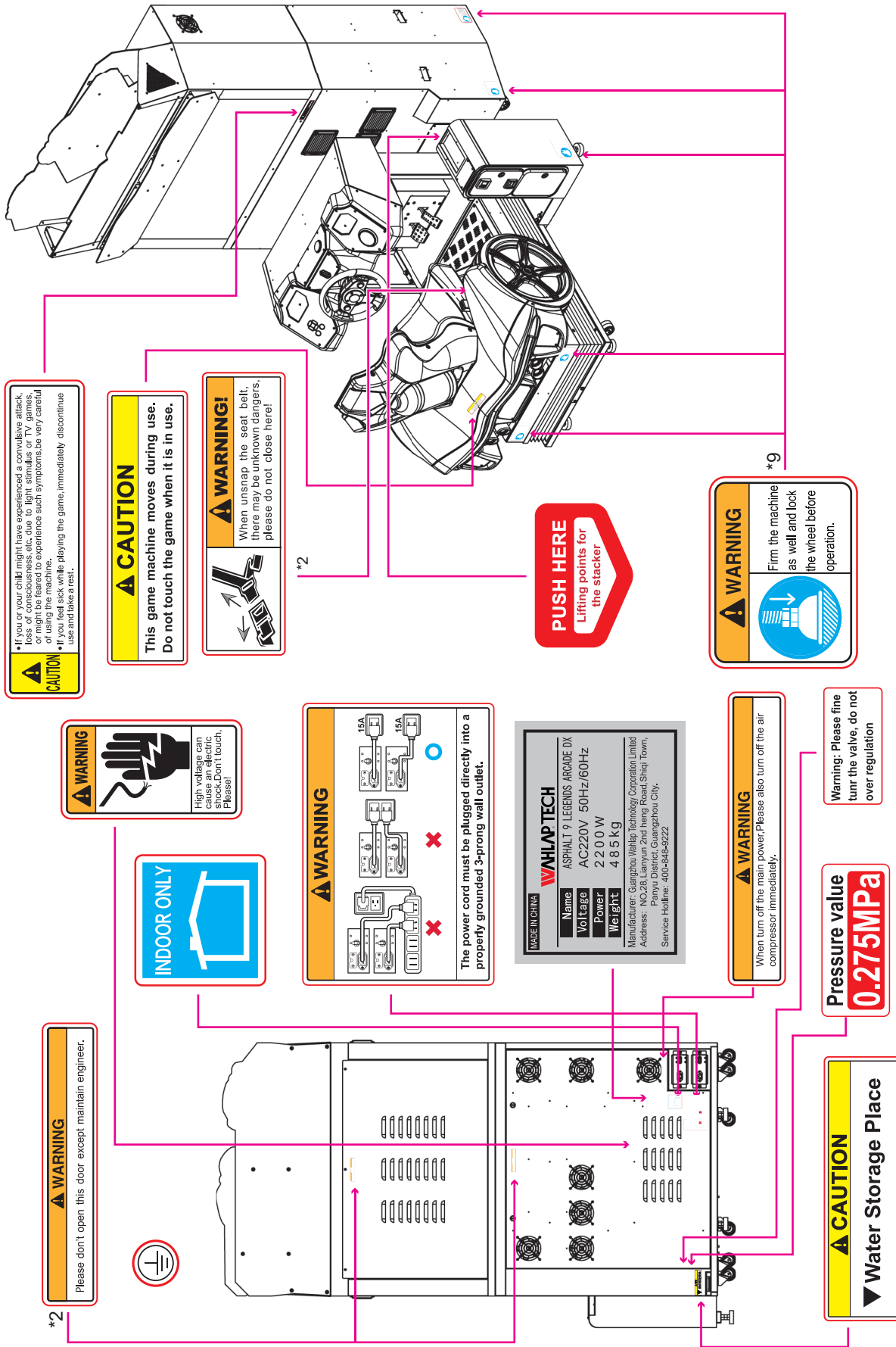

Diagram (3)



Diagram(4)

1.7 Caution & Warning Stickers



CAUTION
 • If you or your child might have experienced a convulsive attack, dizziness, nausea, etc. due to light stimulus or TV games, please stop the game and avoid the experience such symptoms as very careful of using the machine.
 • If you feel sick while playing the game, immediately discontinue use and take a rest.

CAUTION
 This game machine moves during use. Do not touch the game when it is in use.

WARNING!
 When unsnap the seat belt, there may be unknown dangers, please do not close here!

PUSH HERE
 Lifting points for the stacker

WARNING
 Firm the machine as well and lock the wheel before operation.

WARNING
 High voltage can cause electric shock. Don't touch. Please!

INDOOR ONLY

WARNING
 The power cord must be plugged directly into a properly grounded 3-prong wall outlet.

WHLAP TECH	
MADE IN CHINA	
Name	ASPHALT 9 LEGENDS ARCADE DX
Voltage	AC220V 50Hz/60Hz
Power	2200 W
Weight	48.5 Kg
Manufacturer: Guangzhou Whlapp Technology Corporation Limited	
Address: NO.28, Liyunyun 2nd Ring Road, Shiqi Town, Panyu District, Guangzhou City.	
Service Hotline: 400-848-9222	

WARNING
 When turn off the main power, please also turn off the air compressor immediately.

Warning: Please fine turn the valve, do not over regulation

WARNING
 Please don't open this door except maintain engineer.

CAUTION
 Water Storage Place

Pressure value
0.275MPa

2. Product Description

2.1 Product Specification

■ Location	Indoor Only
■ Dimension	1365(W)×2170(D)×2460(H)
■ Rated Voltage·Frequency	AC220V 50Hz/60Hz
	AC110V 50Hz/60Hz
■ Power Consumption	2200W
■ Weight	485kg
■ Temperature Range	5~40 °C

*110V voltage can be set through the transformer and fuse. Please contact the distributor for details.

NOTE: The contents herein described are subject to change without notice.

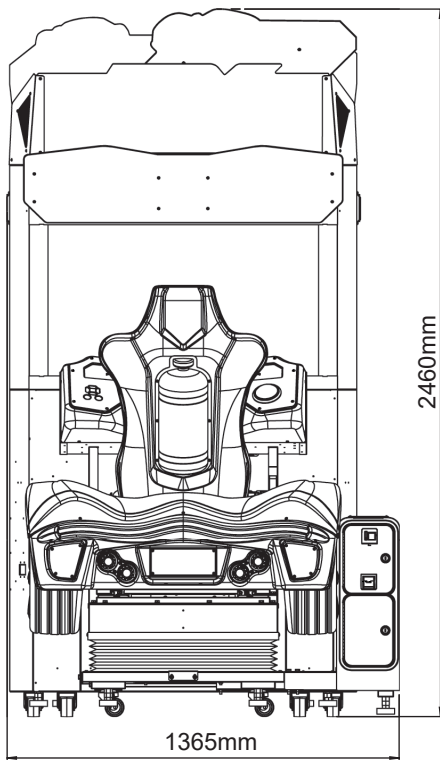

■ Front View

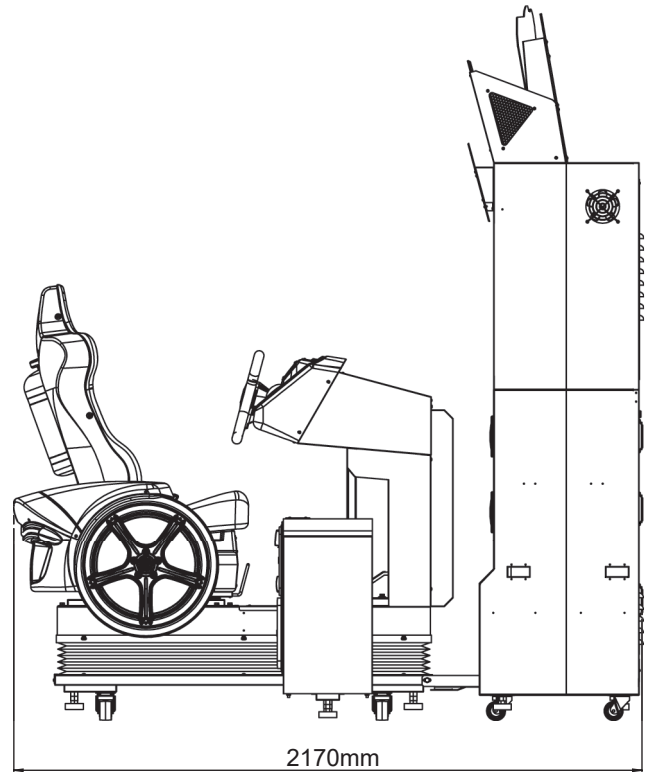

■ Side View

2.2 Overview

■ Side View

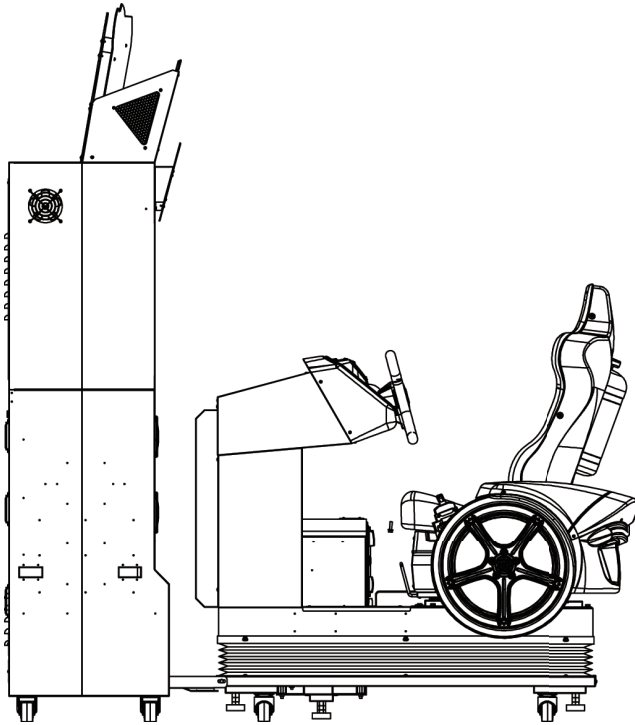

■ Rear View

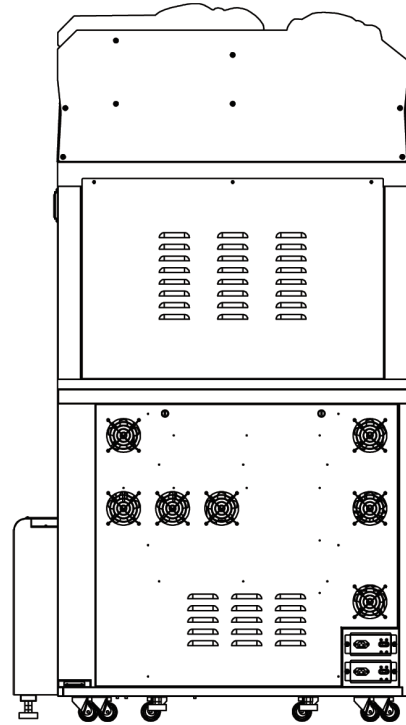

■ Top View

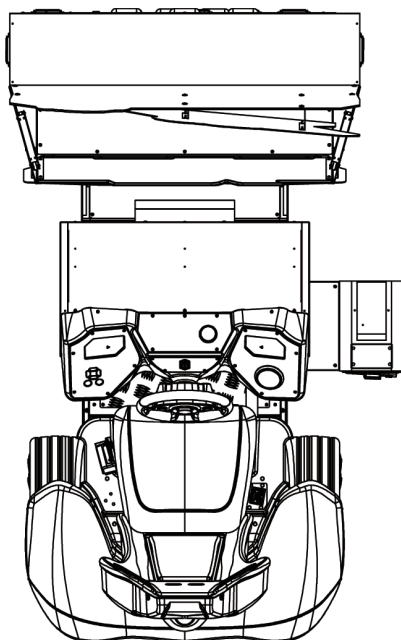

■ Bottom View

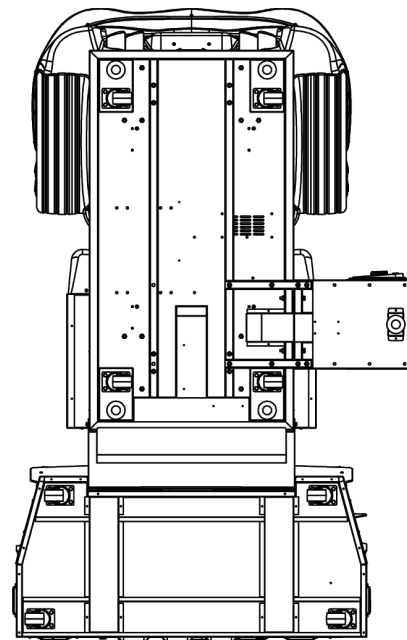

2.3 Parts Name

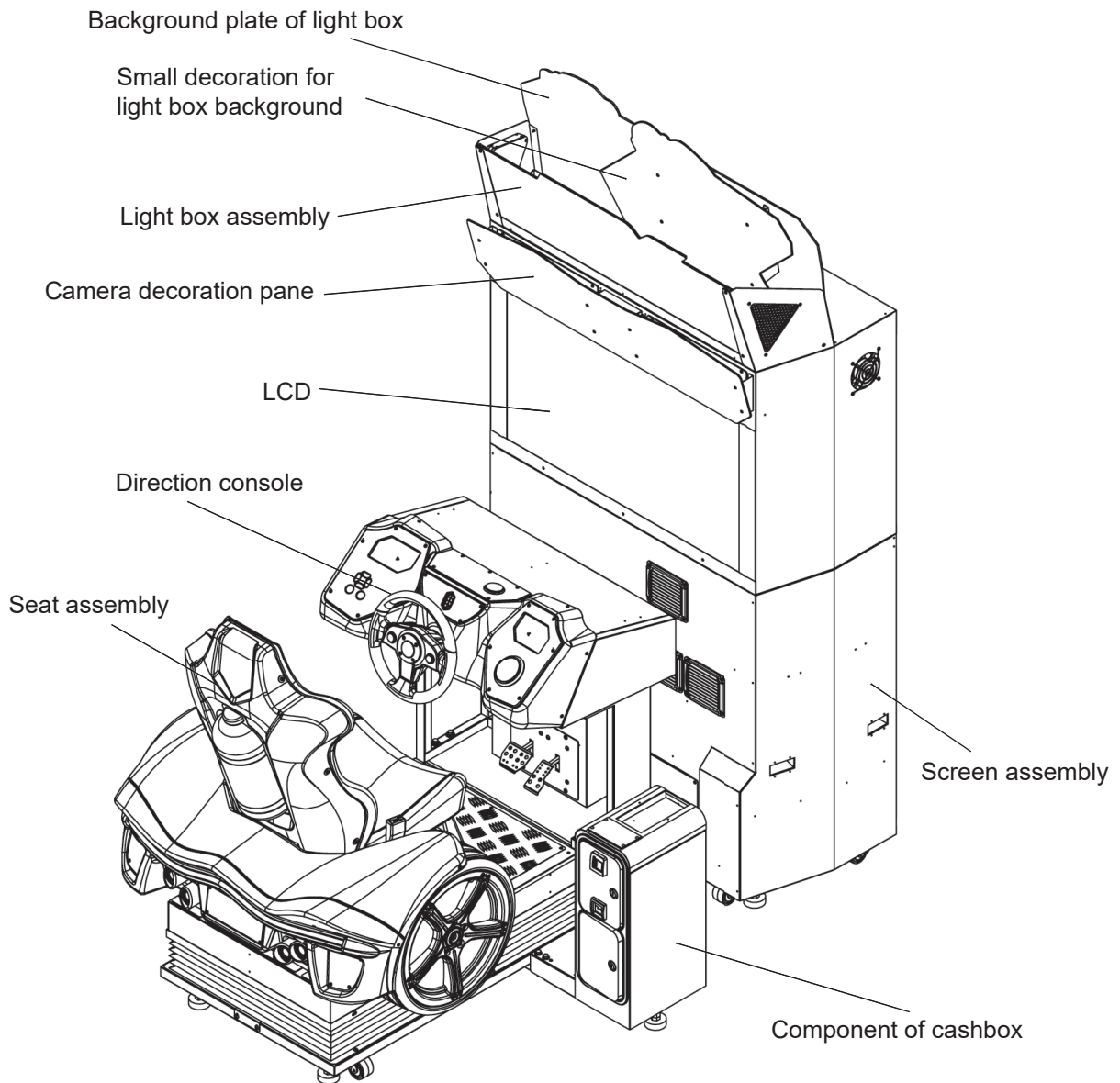

2.4 Shipment List

■ Packing Carton 1

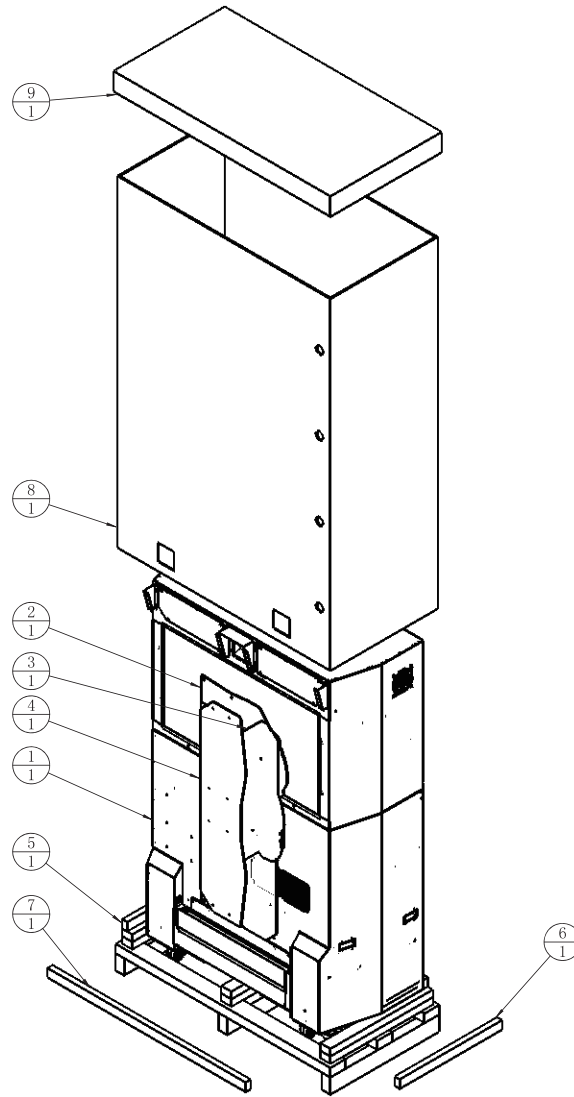

产品名称 Machine Name	ASPHALT LEGENDS	
箱体重量 Box Weight	290 kg	
箱体尺寸 Box Size	1300 × 660 × 2100 mm (W) (D) (H)	
箱体备注 Note	荧幕框主件、灯箱背景板、 灯箱背景小装饰、摄像头装饰板	
C/NO.	1/3	条形码粘贴处

9	A9DX-9901E05	screen cover	water 2C850gT-7	1	
8	A9DX-9901E04	screen coaming	water 2C850gT-7	1	
7	A9DX-9901E03	screen Platform limit wood 2	wood : 30*50*1200	1	
6	A9DX-9901E02	screen Platform limit wood 1	wood : 30*50*620	1	
5	A9DX-9901E01	screen Platform	wood	1	
4	A9DX-P0004	Camera decorative plate	PMMA-3.0T	1	
3	A9DX-P0013	Light box background decoration	PMMA-3.0T	1	
2	A9DX-P0012	Light box background board	Andy board-5.0T	1	
1		Machine assembly		1	
No.	Draw No.	Name	Material/Spec.	Qty.	Product Code

■ Packing Carton 2

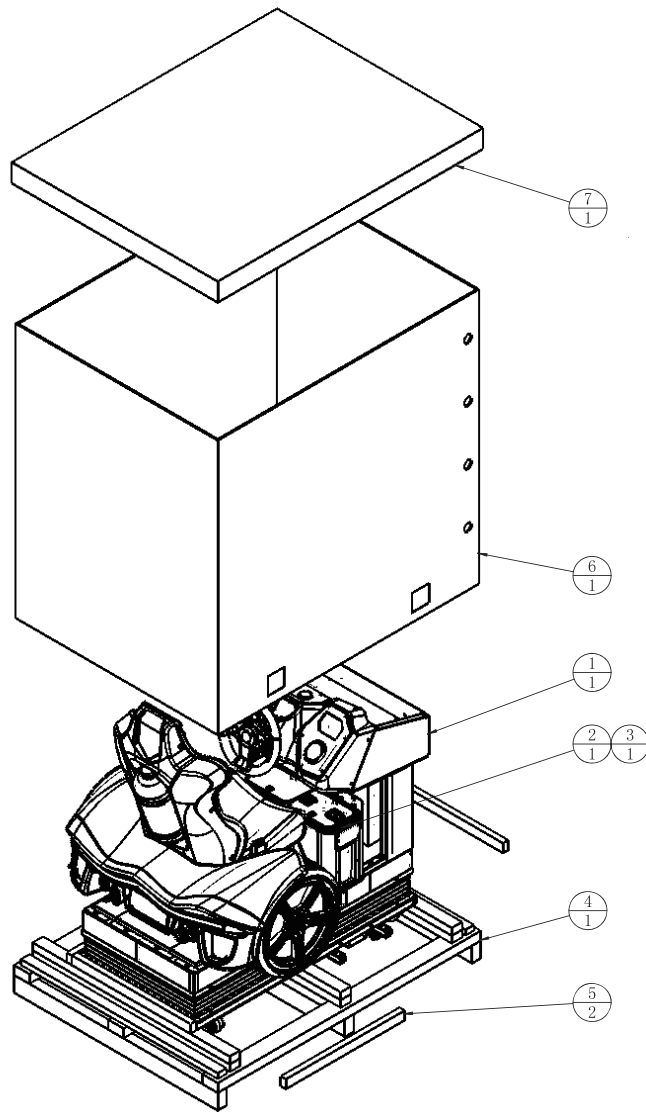

产品名称 Machine Name	ASPHALT ASPHALT ASPHALT
箱体重量 Box Weight	260 kg
箱体尺寸 Box Size	1550 × 1200 × 1650 mm (W) (D) (H)
箱体备注 Box Note	车体平台组件、钱箱组件
C/NO.	2/3

7	A9DX-9902E04	seat cover	water 2C850gT-7	1	
6	A9DX-9902E03	seat coaming	water 2C850gT-7	1	
5	A9DX-9902E02	limit wood	wood : 30*50*700	2	
4	A9DX-9902E01	Platform frame of car body platform	wood	1	
3	A9DX-0000A01	Upper cover of cash box connection	SPCC-1.2T	1	
2	A9DX-0600000	Cash box assembly		1	
1		Car body platform assembly		1	
No.	Draw No.	Name	Material/Spec.	Qty.	Product Code

■ Packing Carton 3

产品名称 Product Name	ASPHALT 3	
箱体重量 Box Weight	13	kg
箱体尺寸 Box Size	1250 × 460 × 300	mm (W) (D) (H)
箱体备注 Remarks	顶部灯箱组件、附属品箱	
C/NO.	3/3	零件图位号

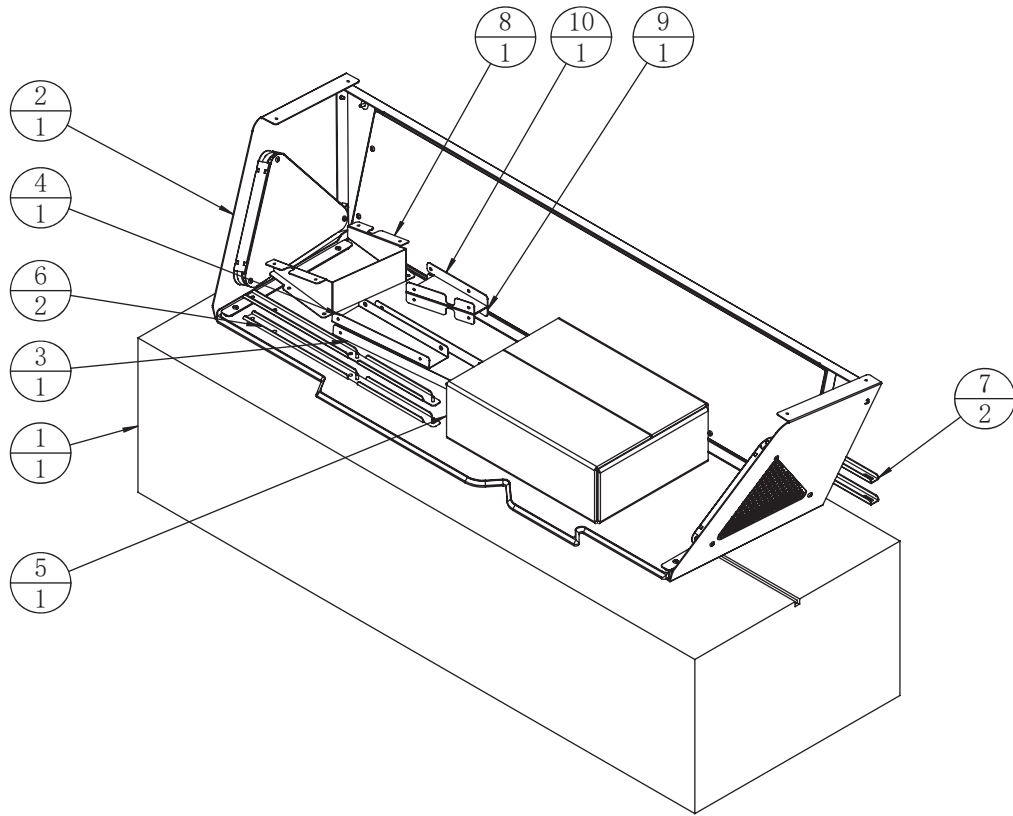

10	A9DX-0100A06	Screen acrylic fixing plate 3			
9	A9DX-0100A05	Screen acrylic fixing plate 2			
8	A9DX-0100A04	Screen acrylic fixing plate 1			
7	A9DX-0700A06	Light box support plate 2	SPCC-1.5T	2	
6	A9DX-0700A05	Light box support plate 1	SPCC-1.5T	2	
5		Accessary List		1	
4	A9DX-0700A04	Haoka board fixing frame 2	SPCC-1.2T	1	
3	A9DX-0700A03	Haoka board fixing frame 1	SPCC-1.2T	1	
2		Top light box assembly		1	
1	A9DX-9903E01	pop packing carton	K=K	1	
No.	Draw No.	Name	Material/Spec.	Qty.	Product Code

2.5 Packing List

Please check the following items after purchasing our product. If any part missing or damaged, please contact our sales person!

Description	Specification	Quantity	Remarks
The anchor antiskid rubber pad	Black rubber-8.0T	4	
Anchor anti-skid pad fixing plate		4	
Weld 1 of anchor anti-skid pad fixing plate	SPCC-1.5T	1	
Weld 2 of anchor anti-skid pad fixing plate	SPCC-1.5T	1	
Water collecting tray		1	
Water collecting tray weldment 1	SPCC-1.2T	1	
Water collecting tray weldment 1	SPCC-1.2T	1	
external hex socket screw	M8*80 (black)	6	
Hexagon triple combination	6*16*12*1.2(black)	8	
spring washer	M8 (black)	6	
plain washers	φ8*φ16*2.0 (black)	6	
hex socket cap screws	M4*8 (Chrome)	8	
cross the big flat head screw	M4*12 (Chrome)	12	
Hex head Cap Screw	M4 (Plating color)	4	
Lexus key		2	
sponge	sponge 200mm*100mm*20mm	1	
network cable	AMP Gigabit network cable 5M	1	
ac cable	3m (1.0m m ²)	2	
Manual	coated paper	1	
cross the big flat head screw	M4*12 (black)	8	

2.6 Install Direction

1. Remove the top light box package, and take out the top light box assembly, Haoka board fixing frame 1, Haoka board fixing frame 2, light box supporting plate 1, Light box support plate 2;

Remove the screen packaging, take out the light box background plate and light box background decoration;

Use four cross big flat head screws M4*12 (chrome-plated) and four nuts to lock the HOKA plate holders 1, 2 and two light box support plates 1. On the light box background board;

Fix the small decorations on the background of the light box together with four cross big flat head screws M4*12 (chrome plated);

Fix the small decorations on the background of the light box together with four cross big flat head screws M4*12 (chrome plated);

Use four cross big flat head screws M4*12 (chrome-plated) to fix the two light box support plates 2 together with the ones installed on the top light box. On the component.

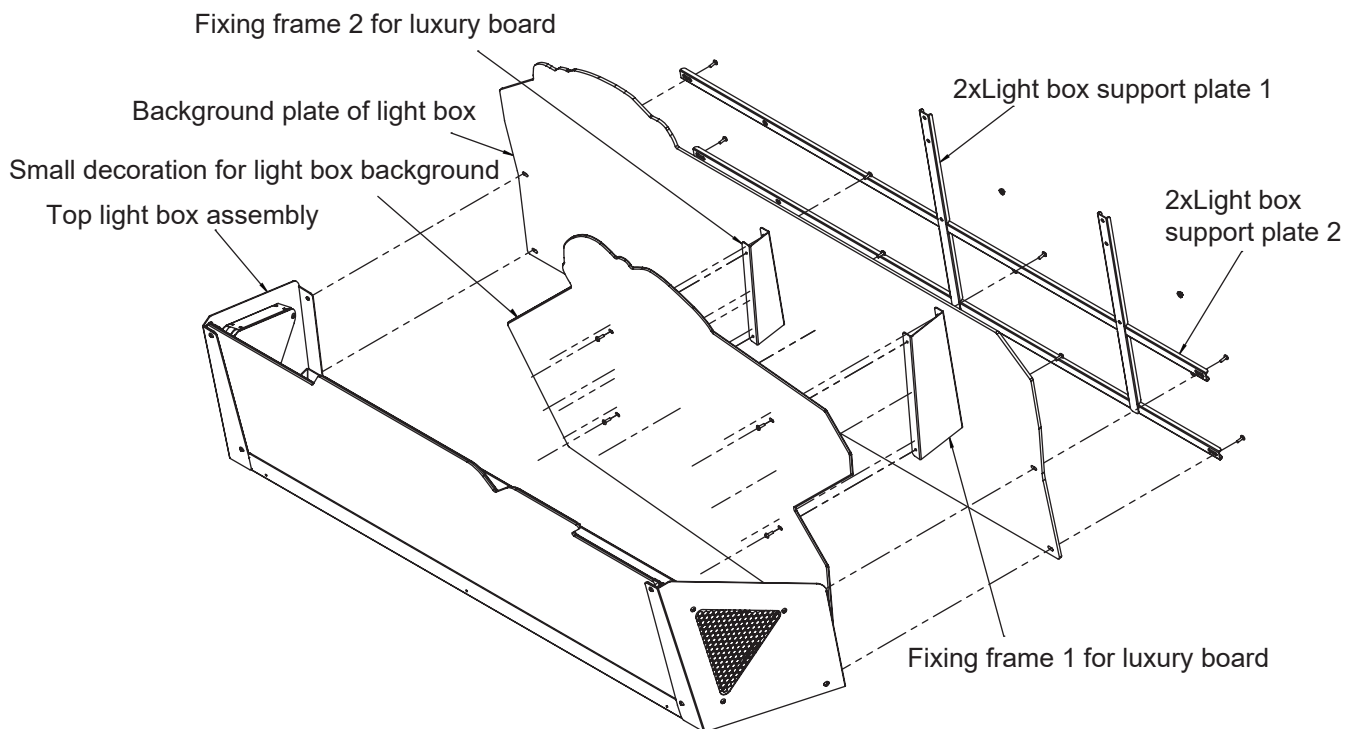

2. Open the maintenance door on the back of the screen frame assembly, lift the top light box assembly on the screen frame assembly, lock the top light box assembly with 8 external hexagonal triad 6*16*12*1.2 (black plating), and lock the screen acrylic fixing plate I, the screen acrylic fixing plate II and the screen acrylic fixing plate III on the machine table with 8 cross flat head screws M4*8 (black plating).

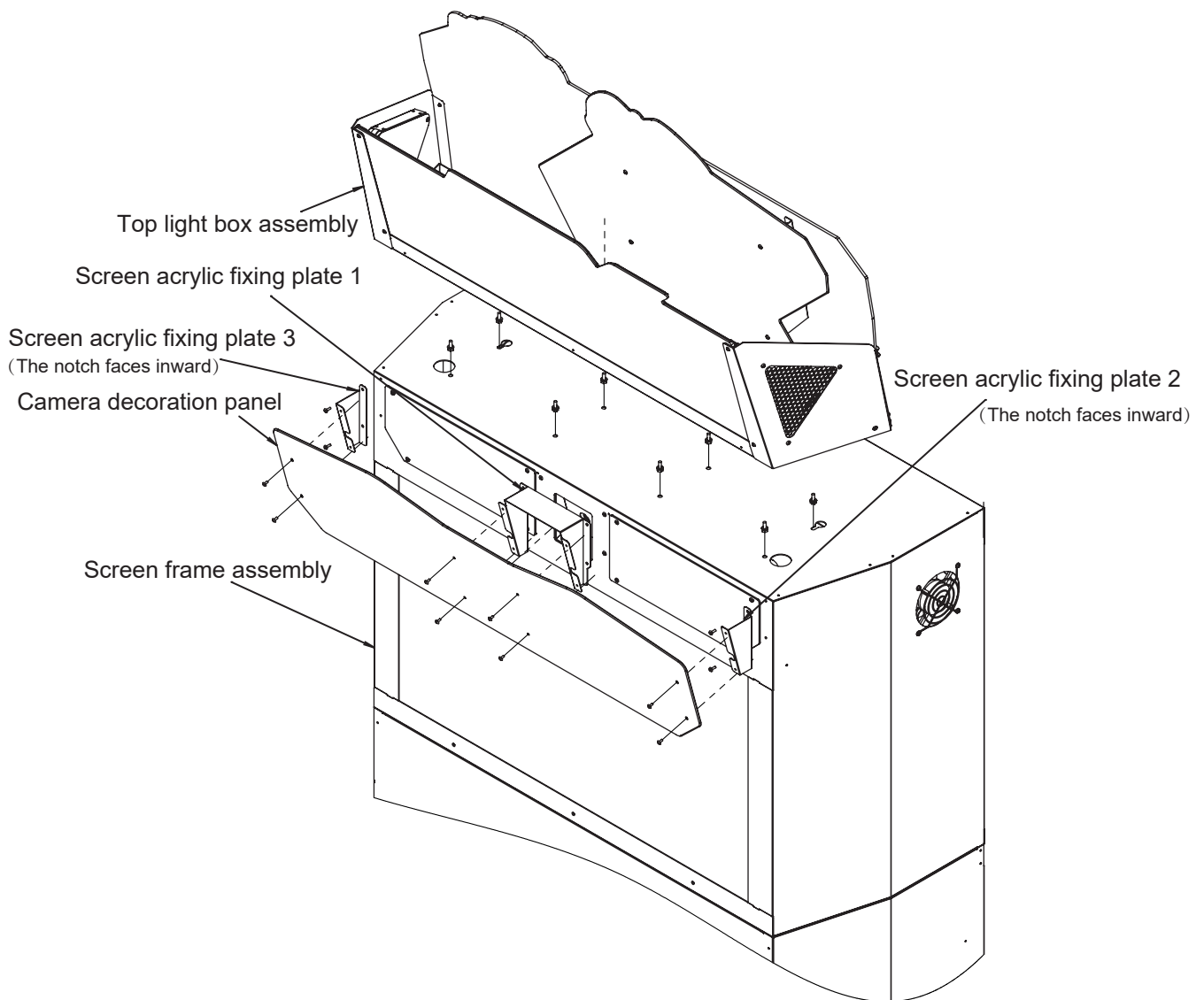

3. Disassemble the package of the car body platform, remove the two external hexagon triple screws on the connecting fixing plate (retaining screws), put down the connecting fixing plate and remove the four cross big flat head screws on the connecting cover plate (retaining screws), fix the car body platform components with the removed two external hexagon triple screws, connect the wires, and fix the connecting cover plate again with the removed four cross big flat head screws.

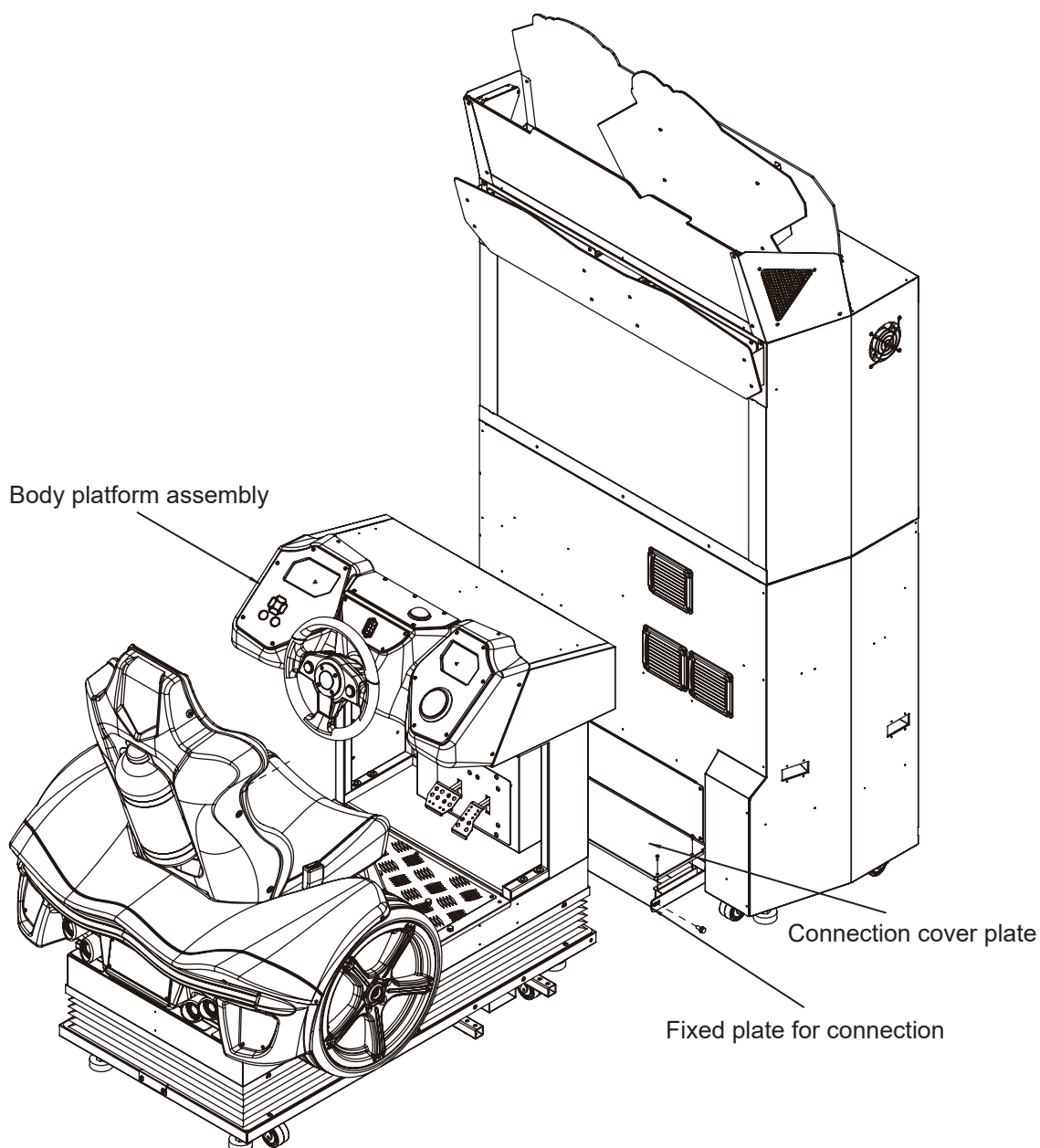

4. Remove four cross large flat head screws for connecting upper cover of cashbox (retaining screw), use six hexagonal screws M8*80 (black plated), spring washers M8 (black plated), flat gaskets $\phi 8 \times \phi 16 \times 2.0$ (black plated) to fix the cashbox assembly onto machine; use the retained four cross large flat head screws to connect and fix the upper cover of cashbox, connect wires, lock all the maintenance doors, and finally mount four fixing plates for foot non-slip mats and foot non-slip rubber mats under the foot to prevent displacement of the machine caused by shaking.

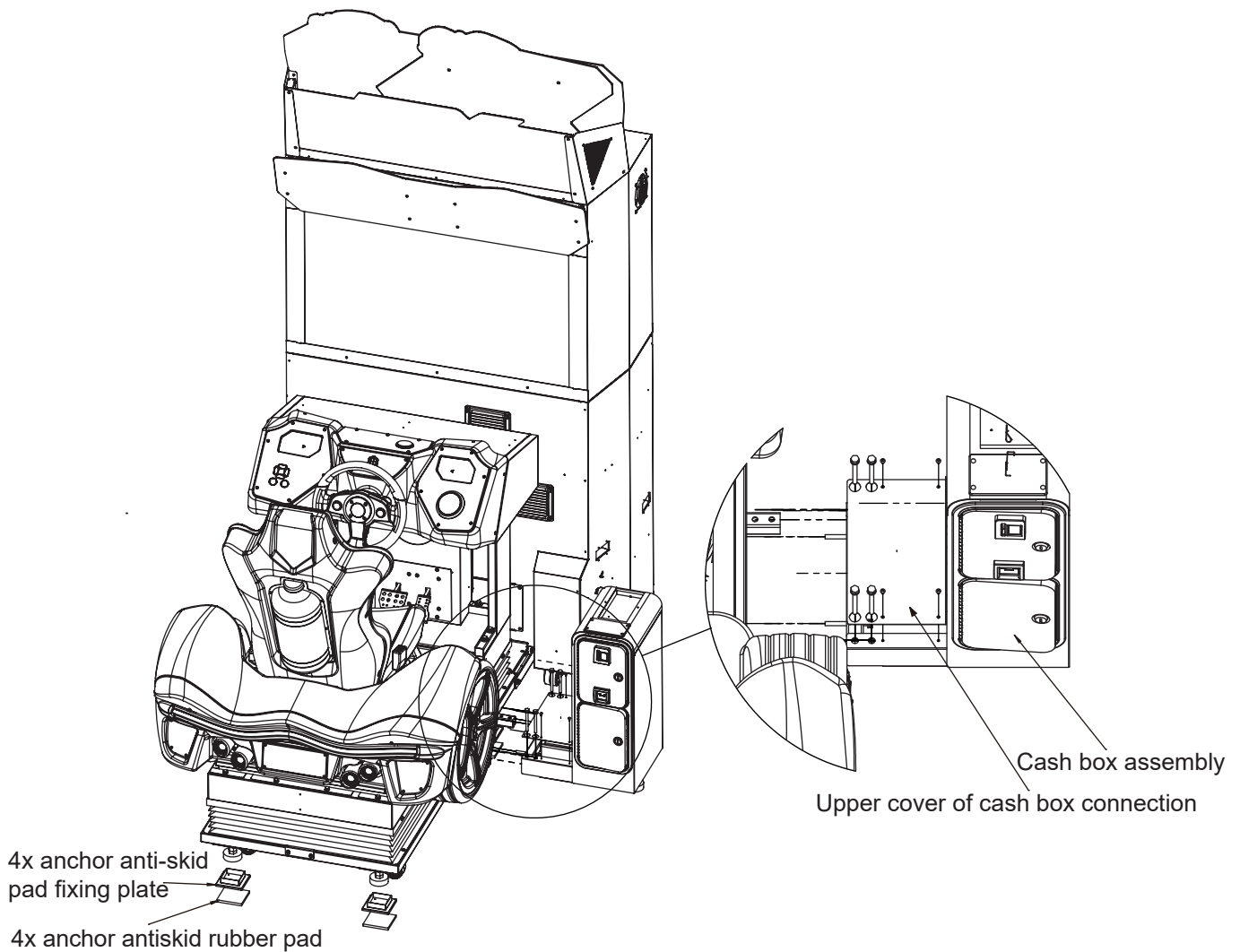

Special attention: When special case occurs in shipment, please check “Installation guide” in attachment box of shipment, and make assembly according to installation guide; special supplement will not be made in this instruction.

2.7 Warranty

■ Scope

- Inquiry regarding product can be assisted for free.
- The warranty scope for consumables and durables may differ from product to product. Please contact our after-sales service center for detailed information. The right of final interpretation is reserved.

■ Exclusive

- Damage caused by force majeure such as god will.
- Failure caused by carelessness, such as water contact, falling down, toppling, knocking.
- Failure caused by disobeying the instructions in this manual.
- Failure caused by operating the machine on inappropriate site.
- Change the original design and configuration for the game without notice.
- Failure to perform regular service and clean.
- Failure to fix the product in line with the manual's requirement.
- Malfunction or part damage caused by electromagnetic interference other electronic equipments generated.

■ Non-warranty Consumables

- Light tube and bulb
- Button lamp and switch
- Fragile items
- Solenoid
- Other spare parts

3. Game Description

3.1 Appearance Design

1. Red is the main color for appearance and color of product, the red represents the speed and passion; for appearance design of machine, being main body, console or seats, streamline red is the main style, which not only lets the whole product looking gorgeous and full of movement on the vision, but also takes players in the racing game full of passion and experience truly;
2. The machine name is equipped with light, bright and conspicuous; on the top, the image of two racing cars galloping in the racing field is used as the background plate; with sparks and tilting car body, the fierce competition in the racing field is demonstrated, such visual shock will let the player have the eager to try and the impulse to conquer the field;
3. For the thickness and texture of the steering wheel, the linear shape of seat for the back, waist and hip, and the changes in movement, all of them are designed with reference to the real racing car, which is very consistent with the ergonomics and kinematics, so as to replicate the real racing environment for players as completely as possible. In addition, the latest vivid platform device is equipped with vibrating speakers, fans and steering wheel force feedback system; it can simulate collision, bumping, steering, acceleration and other driving behaviors, and thus bring real racing experience for players.
4. In terms of lighting, whether the lights on both sides of top of light box, the console or the light bar of the seat, all of them will be changed accordingly depending on the actual operation of the player (accelerating or braking) in the game. The lights are eye-catching and gorgeous with dynamic music, which can catch the eye of the onlookers well.

3.2 Game introduction

This game is a racing entertainment machine authorized by the famous mobile game "<Asphalt 9: Legends>". It adopts vivid platform devices and is equipped with vibrating speakers, fans, and steering wheel force feedback system to simulate driving behaviors such as collision, bumping, steering and acceleration, bringing real racing experience for players.

Famous luxury cars authorized, realistic and delicate cars and scenes, and special effects for wild racing, it breaks through the player's imagination for racing games; multiple modes to get the car drawings and upgrade the car, making the racing more exciting with better results.

3.3 How to play

1. The traditional steering wheel + foot operation mode, characteristic turbo acceleration, and 360-degree rotation button.
2. Fasten the seat belt first, and then insert the token; via rotating the steering wheel, you can select the game mode, car and track, and then press the start button (or step on the accelerator pedal), the game is about to start. After the game starts, step on the accelerator to play the game. During the game, use the relevant buttons to add different game effects (360-degree rotation button, acceleration).
Left of screen
The left side of the screen shows the player's remaining distance; the upper part of the game screen shows the countdown time of game, player ranking/number of players, and other information.
3. You will experience strong movement in the game, ensure that the seat belt is fastened, and press the emergency stop button in case of emergency.

4. Test and Setting

4.1 Game Description

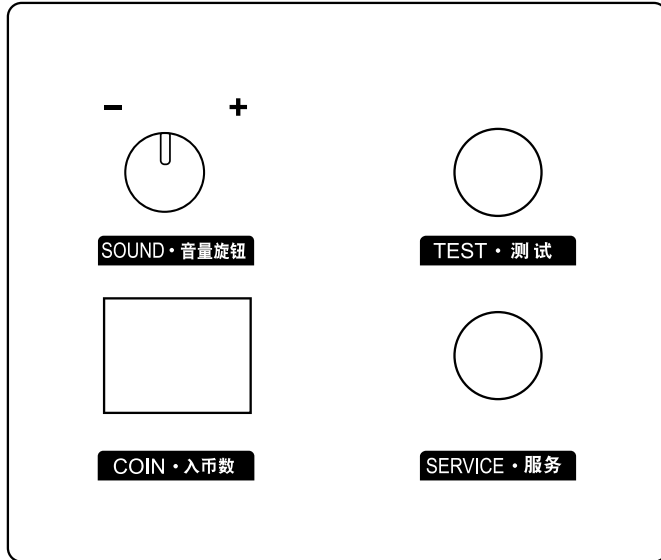

Sound volume knob: Adjust the volume.

TEST: Enter test mode and select

Coins: Coin counter

Service: Enter service points to use as coins without increasing the coin counter.

4.2 Installation

4.2.1 Connection Setting

You can enter **【Connection Setting】** to set up the group number and ID of the cabinet. Enter **【Main Menu】** → **【2 System Setting】** → **【2-2 Connection Setting】**, and appoint all cabinets in connection into the same group, but provide each cabinet a different ID.

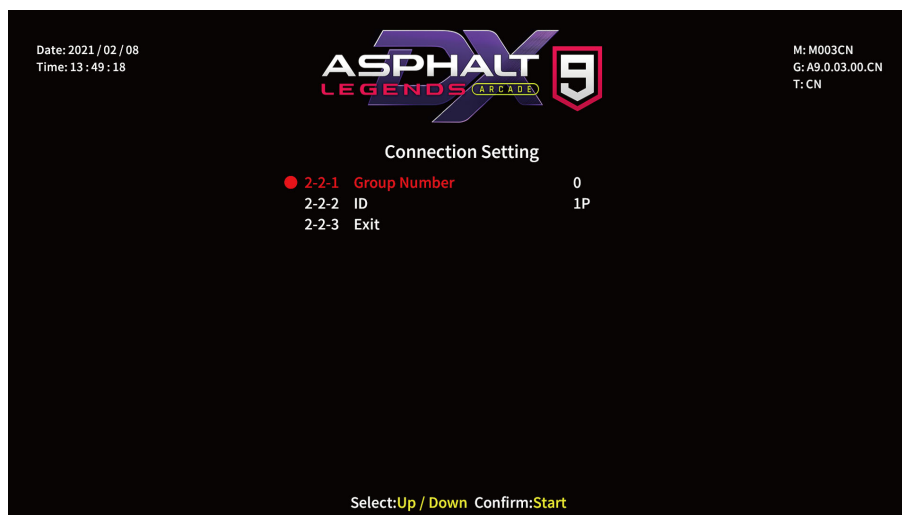

Note: The connection ID of cabinets suggested from left to right in sequence: 1P, 2P, 3P, 4P.

4.2.2 I/O Adjustment

Enter **【Main Menu】** → **【2 System Setting】** → **【2-6 I/O Adjustment】** to run adjustment.

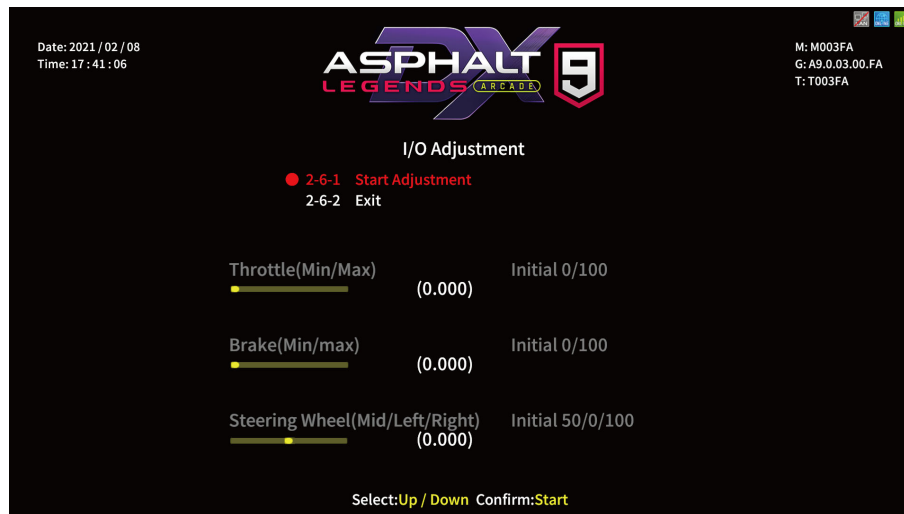

After selecting **【I/O Adjustment】** , it will be adjusted from top to bottom in the Following order

1. Release the throttle and press Nitro button.
2. Step on the throttle and press Nitro button.
3. Release the brake and press Nitro button.
4. Step on the brake and press Nitro button.
5. Adjust steering wheel to middle and press Nitro button.
6. Turn the steering wheel to the left and press Nitro button.
7. Turn the steering wheel to the right and press Nitro button.

4.2.3 Setting Other Related Items

Setting other related items (recommended):

- Enter **【Main Menu】** → **【2 System Setting】** → **【2-1 Time Setting】** , and set the cabinets to be connected to be the same time.
- Enter **【Main Menu】** → **【2 System Setting】** → **【2-3 Country Setting】** and **【2-4 Store Setting】** to set up the location and name of the store.
- Enter **【Main Menu】** → **【3 Game Setting】** → **【3-2 Volume Setting】** , to set up **【3-2-1Daytime Volume Setting】** and **【3-2-2 Evening Volume Setting】**

4.2.4 Important Notes for Staff

When the screen's upper-right corner shows the message **【Platform error!】** or **【Adjustment error!】** in red letters, please follow the steps below to restart the motion platform calibration:

- Open the cabinet's coin insertion compartment
- press the **【Test】** button to enter **【Main Menu】**
- Enter **【Main Menu】** → **【2 System Setting】** → **【2-7 Air Spring Adjustment】** to perform motion platform adjustment (please refer to **【3-4-5 Air Spring Adjustment】** for more details).

- If the error still cannot be resolved by performing the steps listed above, please contact us for repairs.

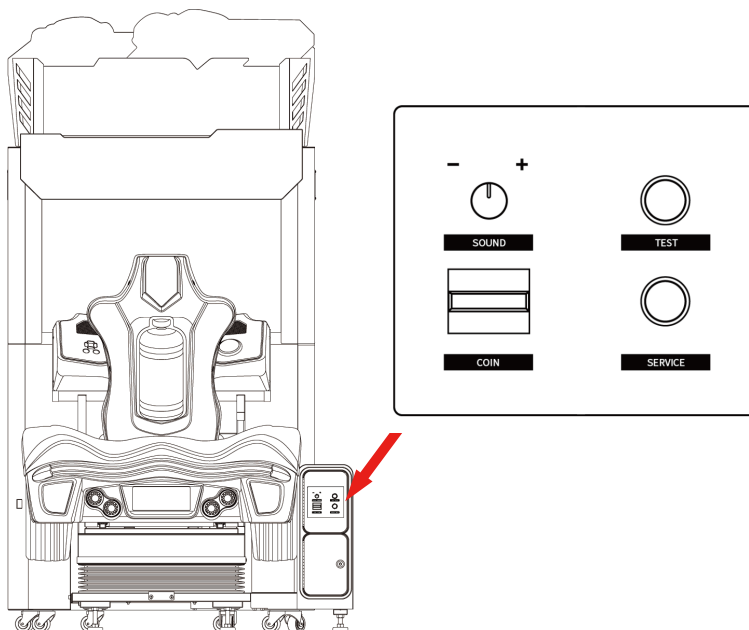

When the screen's lower-left corner shows the icon and the message **【Motion platform OFF.】**, please press the **【Emergency Stop】** button again to cancel the Emergency Stop function.

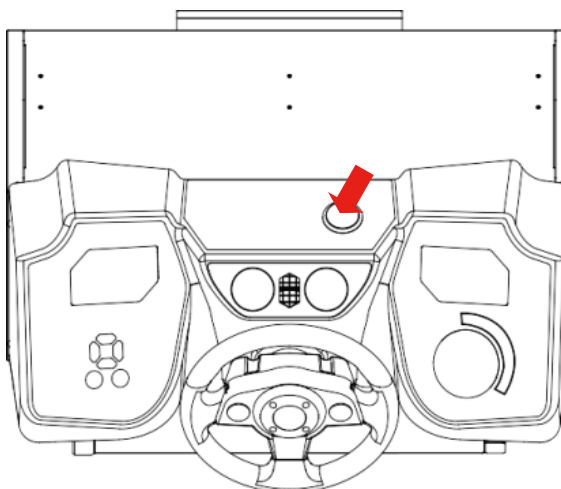

When the screen's upper- right corner shows the message **【I/O 1-1 error】** or **【I/O 1-2 error】**、**【I/O 2 error】** in red letters, please restart the machine. If the error still persists after restarting the machine, please check cable connections or contact us for repairs.

If a player suddenly feels ill during gameplay and needs to stop the game, press and hold the **【Switch】** , **【Nitro】** button、 Step on the Brake to terminate the game early.

4.3 How to Play

Except the basic operations such as speeding and stepping on the brake, other operations are as follows:

1. Turning the steering wheel left / right to select options.

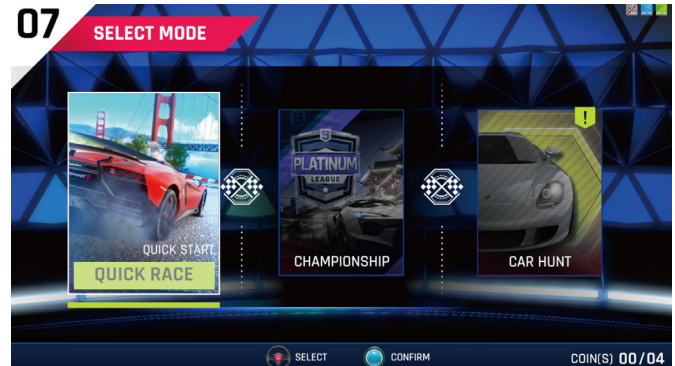

2. Turning the steering wheel to the left or right could make turns.



3. Press the Nitro Button to use Nitro in the game.



4. Press the Wheel Button to perform 360 Stunts in the game.

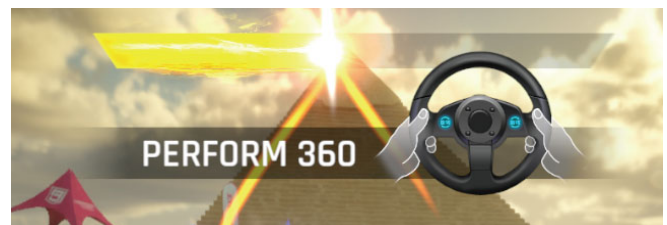

Instructions Of The Control Buttons

Arrow Keys & Start Select and Confirm



Emergency Stop Button
Stop the motion platform during the game

Steering Wheel
Control the car turning



Nitro
Confirm, Nitro

Wheel Button
Perform 360

Throttle & Brake
Control the car speed

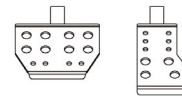

4.3.1 Linking & Networking for Cabinets Information

In the below figure, it shows how the cabinets (no. of cabinets from 2 to 4) should be linked up are as follows: with the router by cables separately.

Note: Please make sure all games are in the same version in order to be linked with.

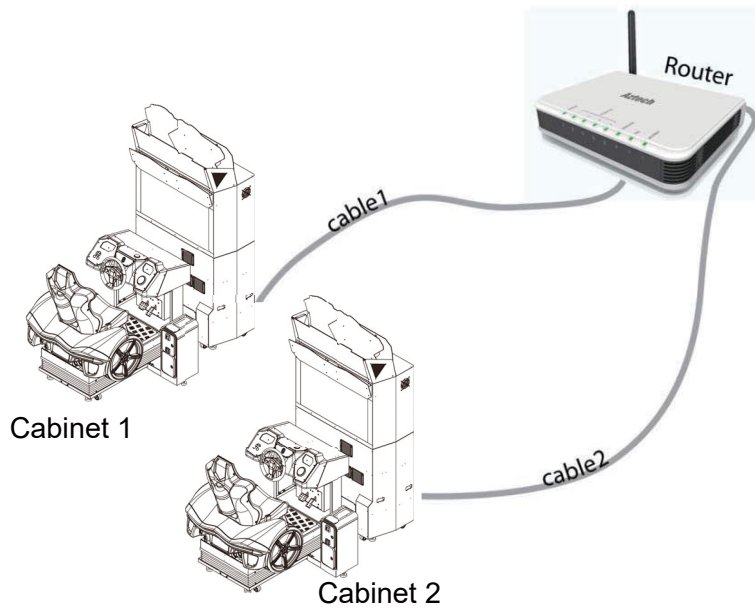

In the router, the LAN ports are where cable(s) to PCS should be inserted; the WAN port is where the Internet cable should be inserted.

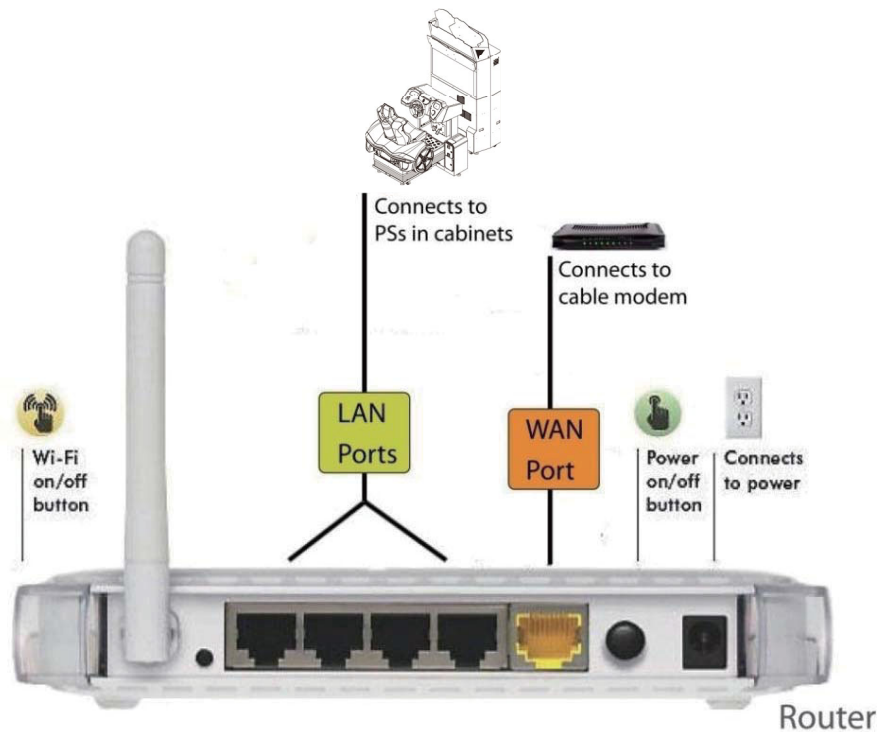

4.4 Instruction Of The Game Display

Game Version Number will appear on the Screen

Connection Setting



Coin(s)

Rank

Nitro Bar

Total Time



Distance Finished

RPM / KPH

Coin(s)

Brand / Car

4.5 Using the Operator Settings

4.5.1 Menu Structure

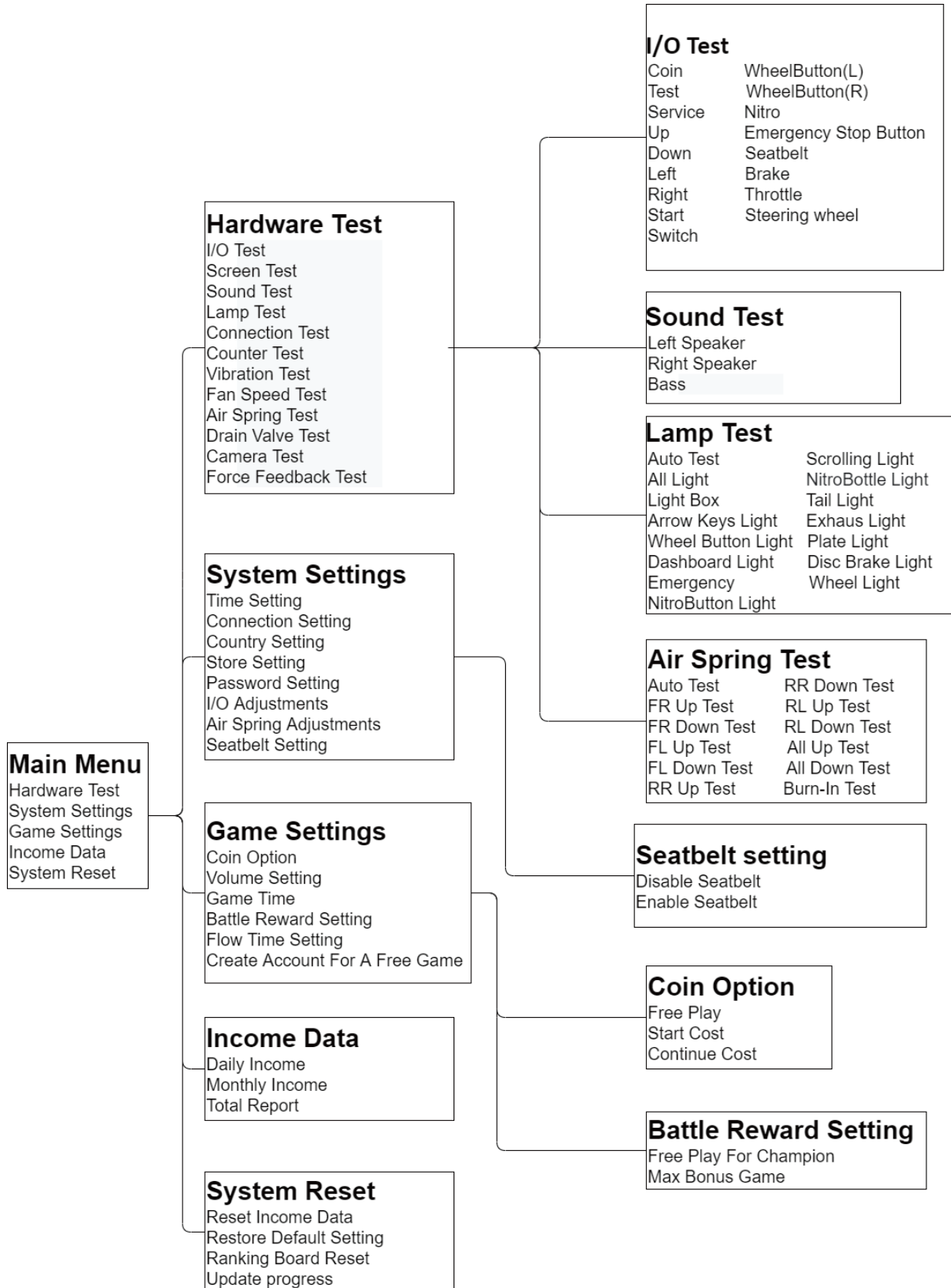

4.5.2 Main Menu Operation

Open the cabinet's coin insertion compartment, press the **【Test】** button to enter **【WARNING】**

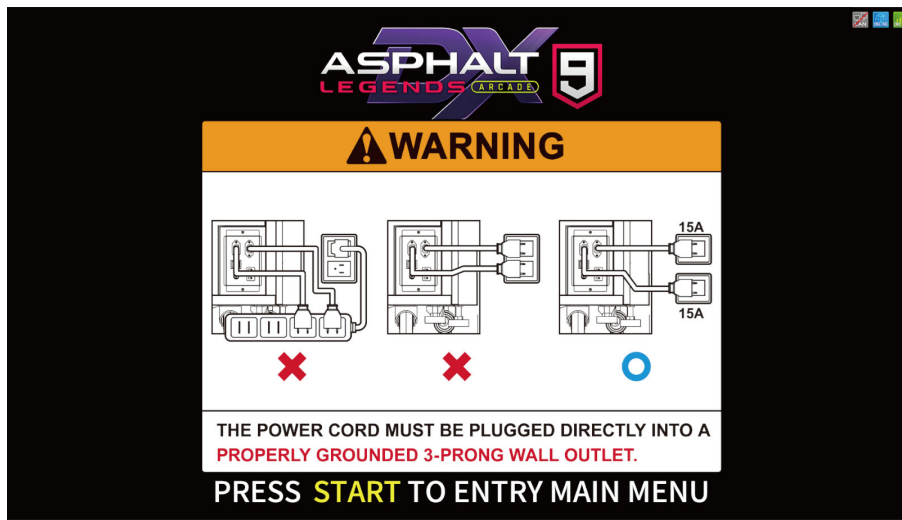

Press the **【Start】** button to enter **【Main Menu】**

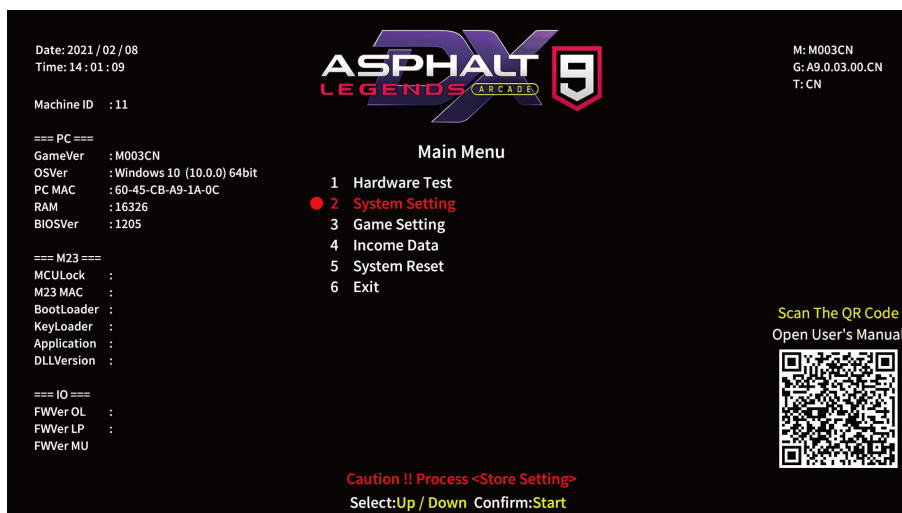

In the menu, follow the steps below to navigate:

- Use the **【Up】** and the **【Down】** to select the options, the option currently selected is marked in red.
- Press the **【Start】** button to confirm the selection or enter the sub-menu.
- After completing the setting or testing, return to Main Menu, use **【Up】** or **【Down】** to select **【Exit】**, then press the **【Start】** button to return to the game screen.

Note: When warning message appear as **【Caution !! Process <I/O Adjustment> <Country Setting> <Store Setting>】** Please process the following setting before exit operator settings.

4.5.3 Hardware Test

You can enter **【Hardware Test】** to test if all hardware is functioning normally or not.

Enter **【Main Menu】** → **【1 Hardware Test】** and the screen will display as below

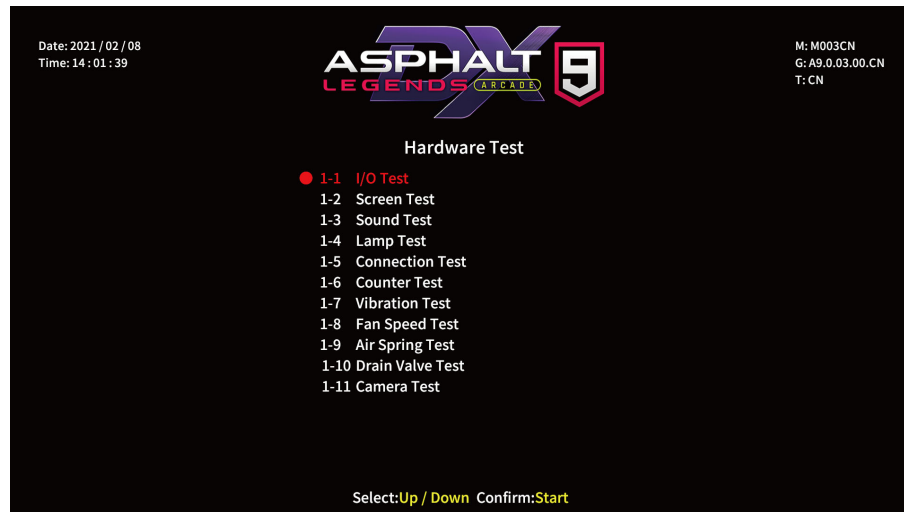

Use the **【Up】** button and **【Down】** button to move the cursor and press the **【Start】** button to enter the sub menu.

After testing is conducted, move the cursor to **【1-13 Exit】** , then press the **【Start】** button to leave this page and return to the **【Main Menu】** .

Regarding detailed descriptions of the sub menu in **【Hardware Test】** , refer to the contents below.

4.5.3.1 I/O Test

In the page of **【I/O Test】** , you can run the testing of specific application to see if it is functioning normally or not.

Enter **【Main Menu】** → **【1 Hardware Test】** → **【1-1 I/O Test】** , and the screen will display as below:

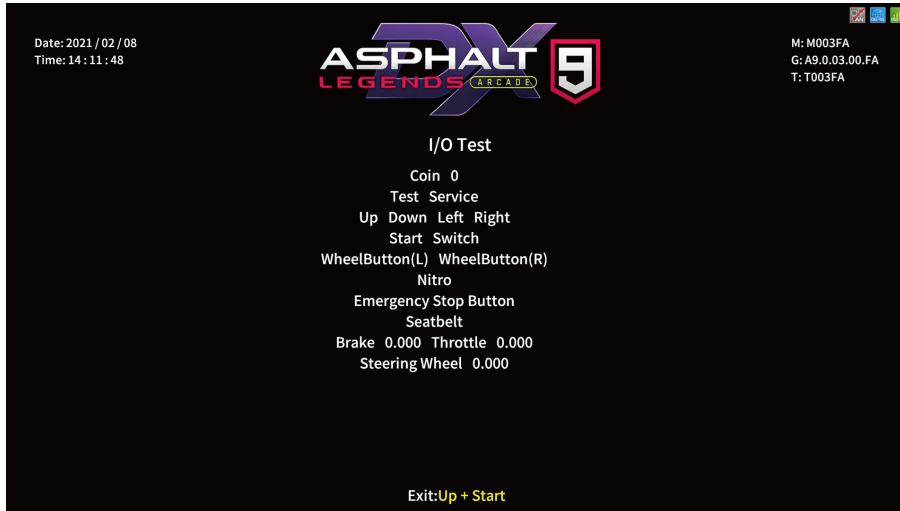

After you enter the page of **【I/O Test】** , you can run the testing of a specific application as explained in the chart below:

Application	Testing method	Result
Coin	Insert coins	When you insert a coin, the amount of coins inserted will increase by 1. Value range between 00 and 99.
Test	Press the button	"White" became "Red"
Service	Press the button	"White" became "Red"
Up	Press the button	"White" became "Red"
Down	Press the button	"White" became "Red"
Left	Press the button	"White" became "Red"
Right	Press the button	"White" became "Red"
Start	Press the button	"White" became "Red"
Switch	Press the button	"White" became "Red"
WheelButton(L)	Press the button	"White" became "Red"
WheelButton(R)	Press the button	"White" became "Red"
Nitro	Press the button	"White" became "Red"
Emergency Stop Button	Press the button	"White" became "Red"
Seatbelt	Fasten seat belt	"White" became "Red"
Brake	Step on the brake	When the brake is release the corresponding status and value will be 0, and when being stepped on it, the value will be around 1
Throttle	Step on the throttle	When the throttle is release the corresponding status and value will be 0, and when being stepped on it, the value will be around 1.
Steering Wheel	Turn the steering wheel to the right and left	When the steering wheel is turning to the left or the right. The corresponding status and value will be around -1 or 1.

After testing is completed, Press the **【Start】** button and the **【Down】** button to leave this page, and return to **【Hardware Test】** .

Note: If the values of the throttle, brake and steering wheel are abnormal, enter **【2-6 I/O Adjustment】** to make adjustments.

4.5.3.2 Screen Test

In the page of **【Screen Test】** , you can test whether the white balance, color level, and lattice are functioning normally or not.

Enter **【Main Menu】** → **【1 Hardware Test】** → **【1-2 Screen Test】** , and the screen will display as below:

After entering **【Screen Test】** , the system will then process the testing, and the following six pictures will be displayed for you to adjust the white balance, color level, and lattice.

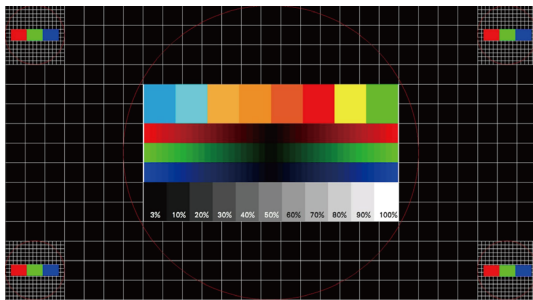

the page of **【Screen Test】** , press the **【Start】** button to change the displayed picture. After the testing is completed, press the **【Start】** button to return to **【Hardware Test】** .

4.5.3.3 Sound Test

In the page of **【Sound Test】** , you can run the testing of specific application to see if it is functioning normally or not.

Enter **【Main Menu】** → **【1 Hardware Test】** → **【1-3 Sound Test】** , and the screen will display as below:

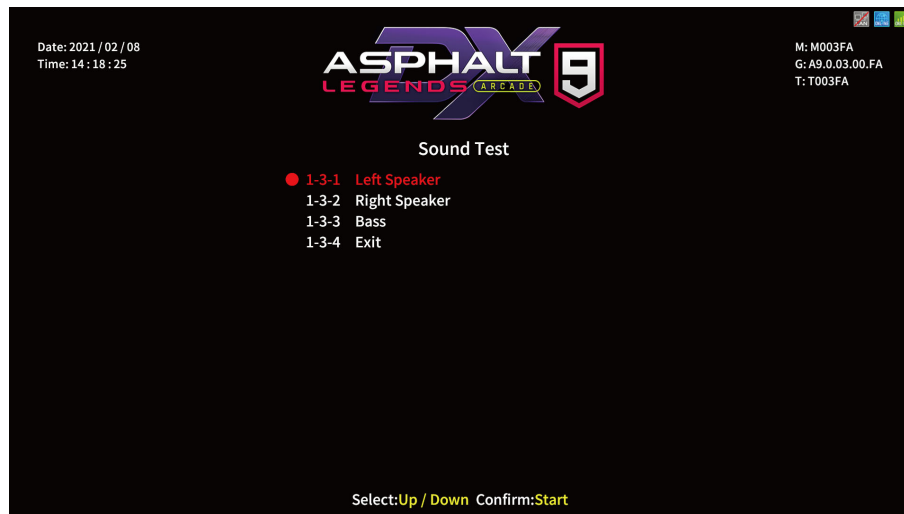

Move the cursor, and choose the soundtrack to be tested, then press the **【Start】** button to start the testing.

The soundtrack being tested will keep producing a certain sound. Press the **【Start】** button to discontinue the testing process.

After the test is completed, move the cursor to **【1-3-4 Exit】** , and press the **【Start】** button to return to **【Hardware Test】** .

4.5.3.4 Lamp Test

In the page of **【Lamp Test】** , you can test if each light is functioning normally or not. Enter **【Main Menu】** → **【1 Hardware Test】** → **【1-4 Lamp Test】** , and the screen will display as below:



Use the **【Up】** button and **【Down】** button move the cursor, then press the **【Start】** button to run testing.

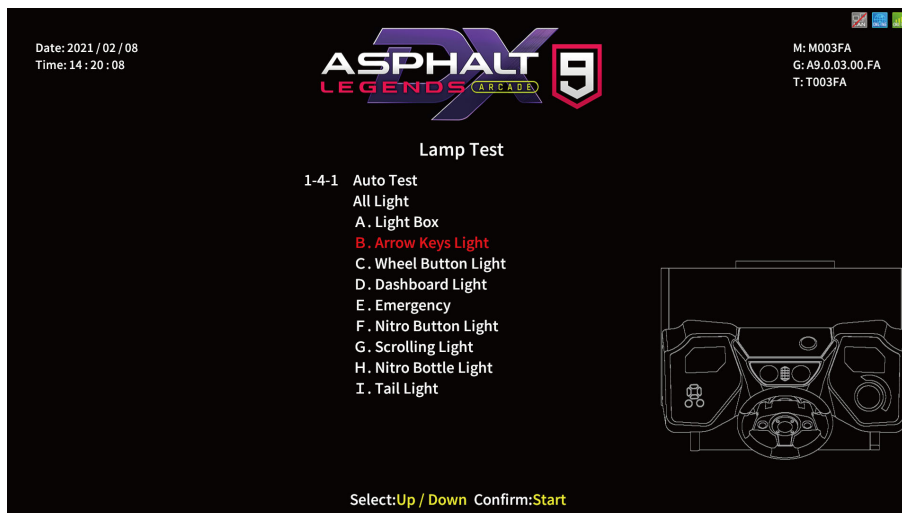

While testing, press the **【Start】** button one more time to discontinue the testing process.

move the cursor to **【1-4-2 Exit】** , and press the **【Start】** button to return to **【Hardware Test】** .

4.5.3.5 Connection Test

In the page of **【Connection Test】** , you can test whether each cabinet of the same group is functioning normally.

Enter **【Main Menu】** → **【1 Hardware Test】** → **【1-5 Connection Test】** , and the screen will display as below:

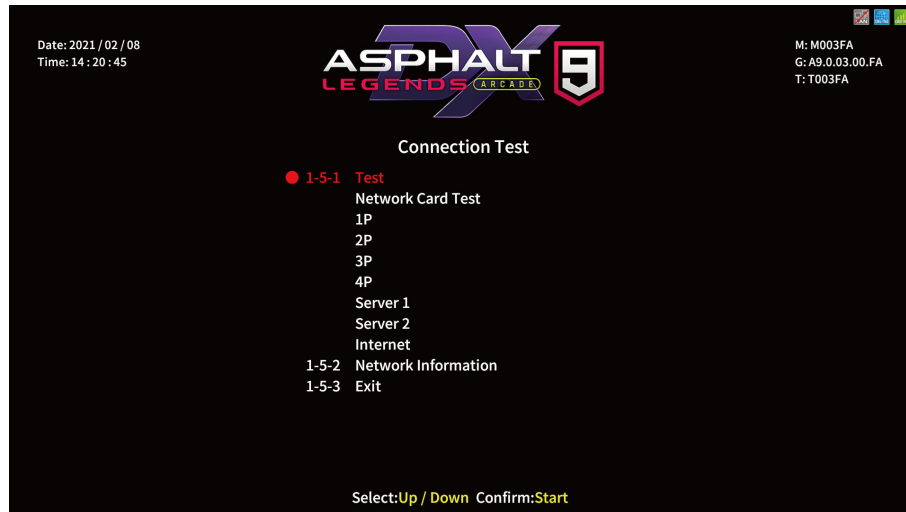

move the cursor to **【1-5-1 Test】** , and press the **【Start】** button to start testing. Possible connection status includes: **【Connected】** , **【Connection Failed】** .

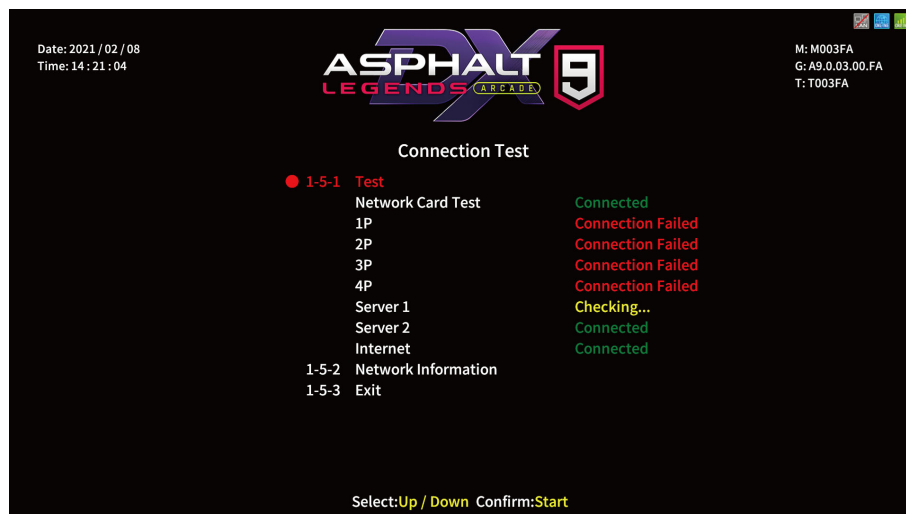

Move the cursor to **【1-5-2 Network Information】** , and press the **【Start】** button to enter the sub menu.

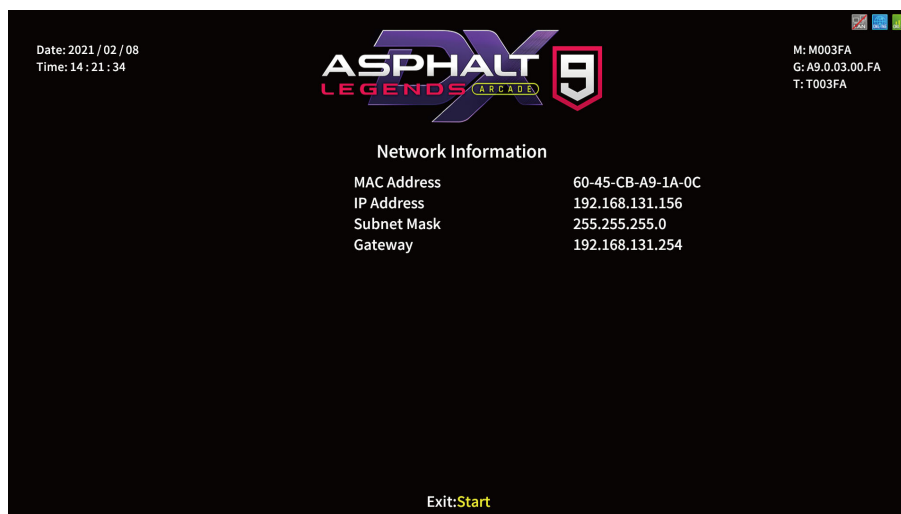

In the page of **【Network Information】** , press the **【Start】** button to return to **【Connection Test】** .

4.5.3.6 Counter Test

In the page of **【Counter Test】** , you can test whether the counter is functioning normally or not.

Enter **【Main Menu】** → **【1 Hardware Test】** → **【1-6 Counter Test】** , and the screen will display as below:

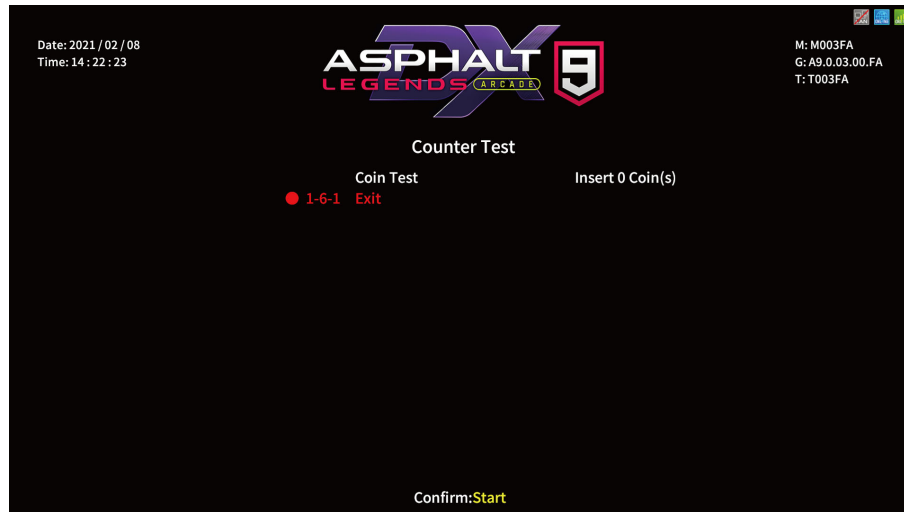

After you enter the page of **【Counter Test】** , insert coins to the coin slot, and the number on the right will go up as more coins are inserted. Also, the counter inside the coin counter will indicate the number too.

After the test is completed, move the cursor to **【1-6-1 Exit】** and press **【Start】** button to return to **【Hardware Test】** .

4.5.3.7 Vibration Test

In the page of **【Vibration Test】** , you can test whether the vibration speaker is functioning normally or not.

Enter **【Main Menu】** → **【1 Hardware Test】** → **【1-7 Vibration Test】** , and the screen will display as below:

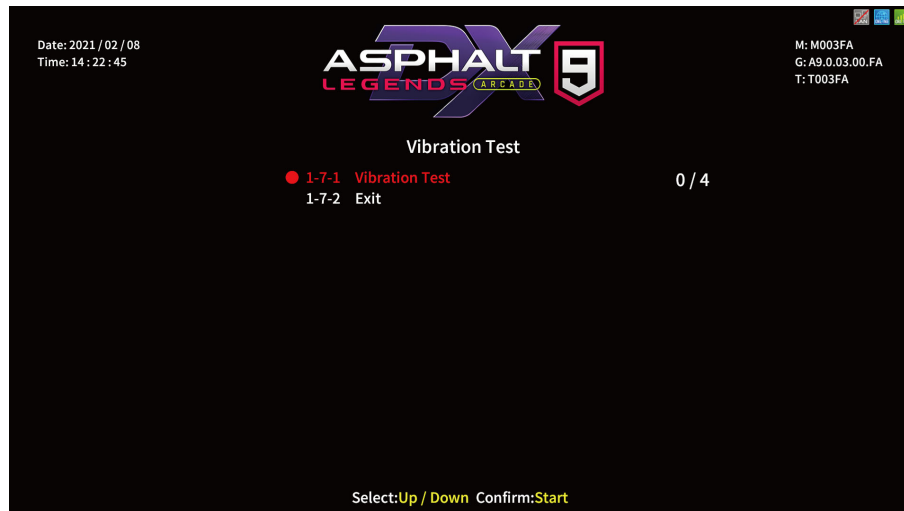

Use the **【Up】** button and **【Down】** button move the cursor, then press the **【Start】** button to run testing.

While testing, press the **【Start】** button one more time to discontinue the testing process.

move the cursor to **【1-7-2 Exit】** , and press the **【Start】** button to return to **【Hardware Test】** .

4.5.3.8 Fan Speed Test

In the page of **【Fan speed Test】** , you can test whether the fan is functioning normally or not.

Enter **【Main Menu】** → **【1 Hardware Test】** → **【1-8 Fan Speed Test】** , and the screen will display as below:

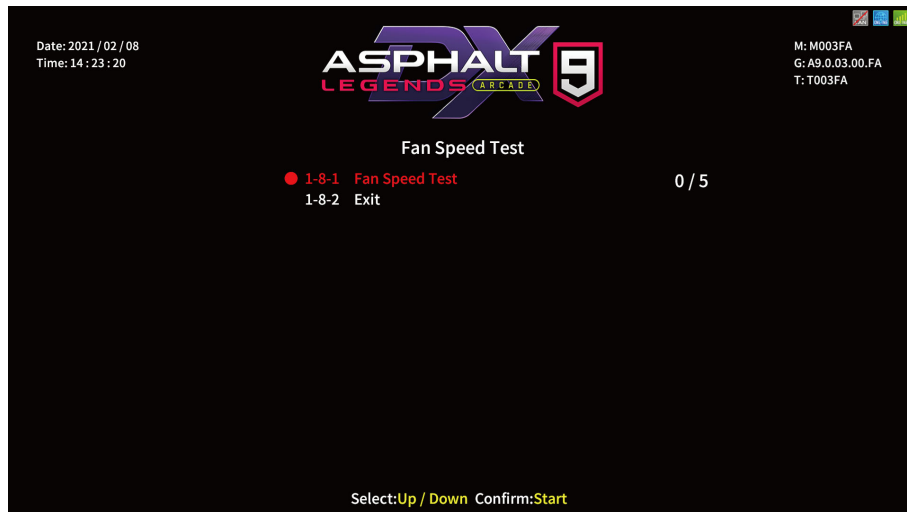

Use the **【Up】** button and **【Down】** button move the cursor, then press the **【Start】** button to run testing.

While testing, press the **【Start】** button one more time to discontinue the testing process.

Move the cursor to **【1-8-2 Exit】** , and press the **【Start】** button to return to **【Hardware Test】** .

4.5.3.9 Air Spring Test

In the page of **【Air Spring Test】** , you can test whether the air spring is functioning normally or not.

Enter **【Main Menu】** → **【1 Hardware Test】** → **【1-9 Air Spring Test】** , and the screen will display as below.

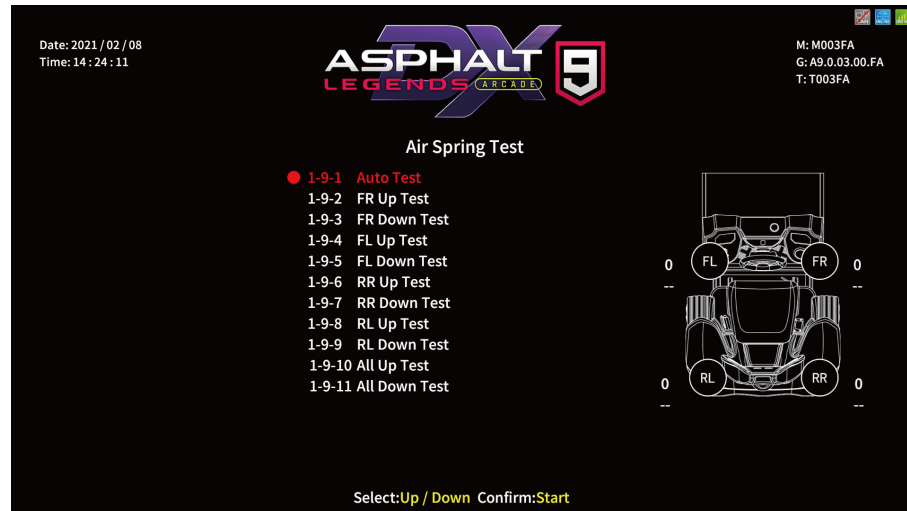

Move the cursor and then press the **【Start】** button to test the air spring on the cursor you have selected.

While testing, press the **【Start】** button will stop the test.

When the **【Emergency stop】** has been activate, the warning message will be appear as **【Motion Off】** .

Move the cursor to **【1-9-12 Exit】** , and press the **【Start】** button to return to **【Hardware Test】** .

4.5.3.10 Drain Valve Test

In the page of **【Drain Valve Test】** , you can test whether the drain valve is functioning normally or not.

Enter **【Main Menu】** → **【1 Hardware Test】** → **【1-10 Drain Valve Test】** , and the screen will display as below:

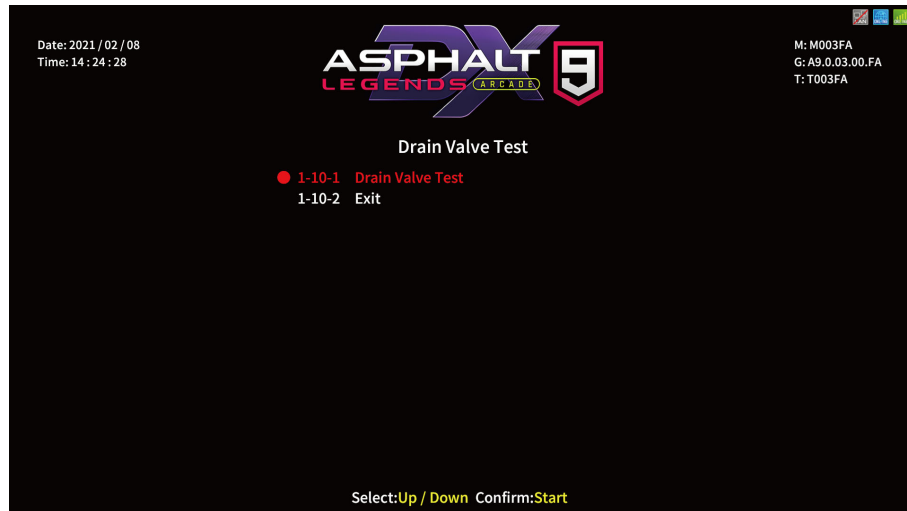

Move the cursor to **【Drain Valve Test】** , then press the **【Start】** button to start testing.

The Drain Valve Test will automatically stop after 5 seconds. In addition, you can press the **【Start】** button one more time to discontinue the testing process.

Move the cursor to **【1-10-2 Exit】** , and press the **【Start】** button to return to **【Hardware Test】** .

4.5.3.11 Camera Test

In the page of **【Camera test】** , you can test whether the drain valve is functioning normally or not.

Enter **【Main Menu】** → **【1 Hardware Test】** → **【1-11 Camera Test】** , and the screen will display as below:



In the page of **【Camera Test】** , An image will appear in the rectangular space. Press the **【Start】** button to return to **【Hardware Test】** .

4.5.3.12 Force Feedback Test

In the page of **【Force Feedback Test】** , you can test whether the force feedback is normally functioning or not.

Enter **【Main Menu】** → **【1 Hardware Test】** → **【1-12 Force Feedback Test】** , and the screen will display as below:

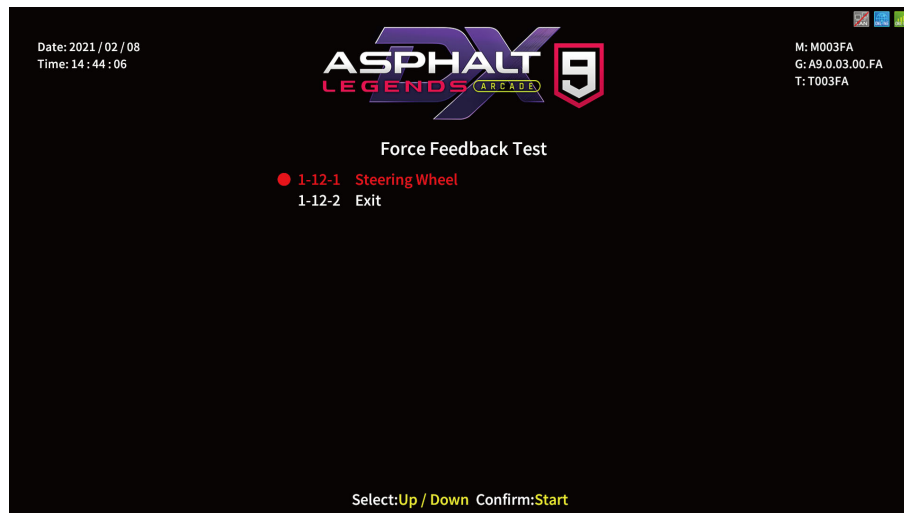

Use the **【Up】** button and **【Down】** button move the cursor, then press the **【Start】** button to run testing.

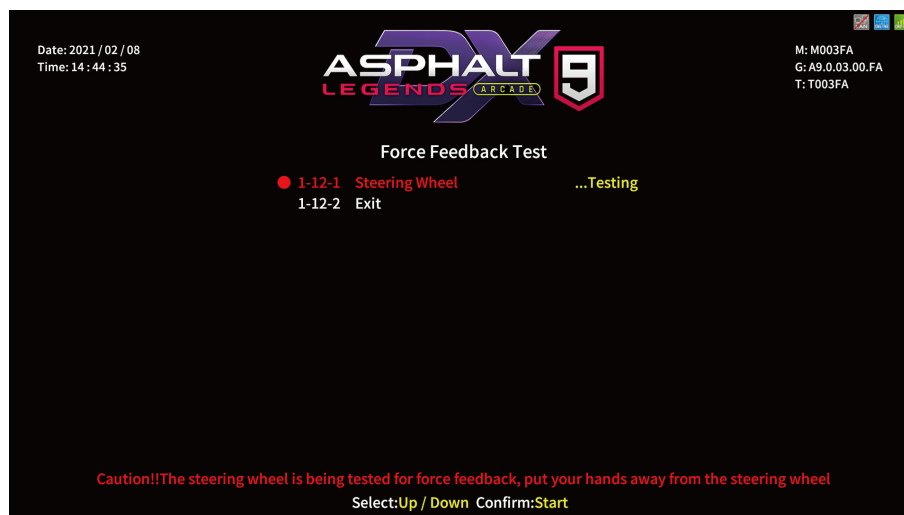

While testing, warning message appear **【Caution!!The steering wheel is being tested for force feedback, put your hands away from the steering wheel】**

Move the cursor to **【1-12-2 Exit】** and press the **【Start】** button to return to **【Hardware Test】** .

4.6 System Setting

In the page of **【System Setting】** , you can set up the system.

Enter **【Main Menu】** → **【2 System Setting】** , and the screen will display as below:

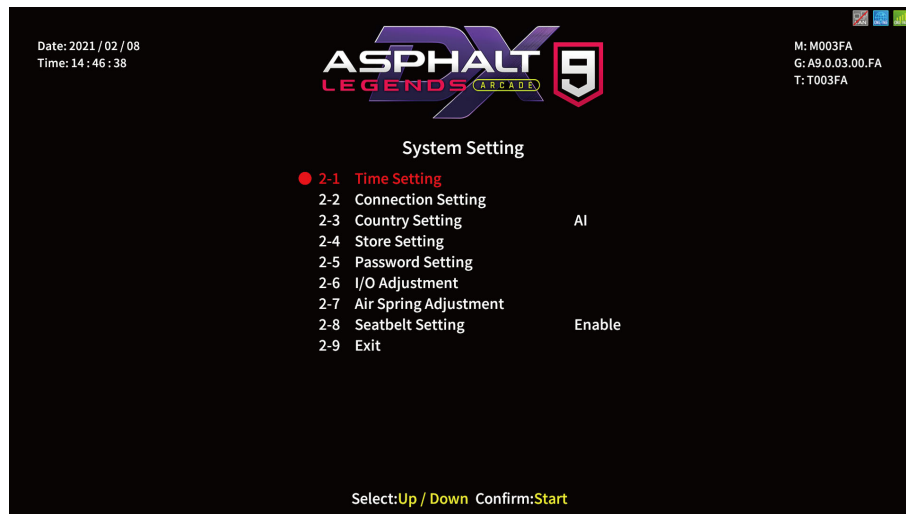

Use the **【Up】** button and **【Down】** button to move the cursor and press the **【Start】** button to the sub menu.

Move the cursor to **【2-9 Exit】** and press the **【Start】** button to return to **【Main Menu】**
Regarding the detailed descriptions of the sub menu in **【System Setting】** , refer to the following content.

4.6.1 Time Settings

In the page of **【Time Setting】** , you can set up your local time.

Note: **【Date】** , **【Time】** will be automatically synchronized with the server's time when connected to the server.

Enter **【Main Menu】** → **【2 System Setting】** → **【2-1 Time Setting】** , and the screen will display as below:

When the machine is not connected to the server, **【Date】** and **【Time】** can be changed. Use the **【Up】** button and **【Down】** button to move the cursor and press the **【Start】** button to set Date and Time.

Move the cursor to **【2-1-4 Exit】** and press the **【Start】** button to enable Time Setting changes. When **【Yes】** is selected, the machine will automatically restart. When **【No】** is selected, the screen will automatically direct to the page of **【System Setting】** .

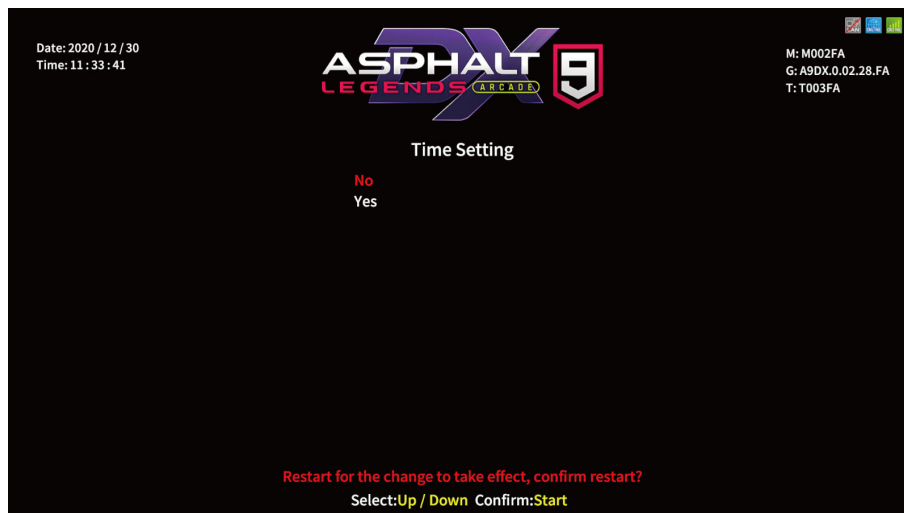

Move the cursor to **【2-1-3 Timezone】** and press the **【Start】** button to enter **【Country Setting】** page.

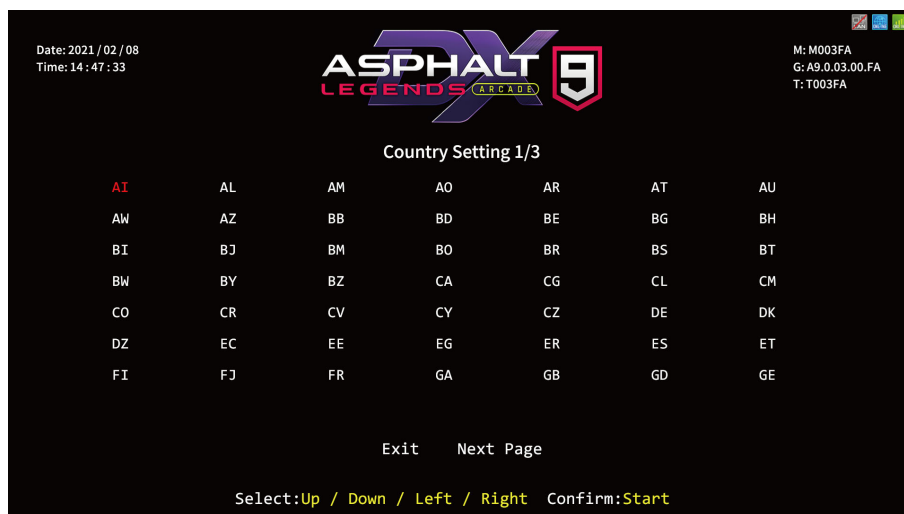

Use the **【Up】** , **【Down】** , **【Left】** , **【Right】** button to move the cursor and press the **【Start】** button to select Country.

If the country chosen has multiple time zone, or **【Other】** is selected, screen will automatically direct to the page of **【Timezone Setting】**



4.6.2 Connection Setting

In the page of **【Connection Setting】**, you can set the group and the ID of the cabinet. Note: To connect to the machine, please set up the same group in the settings. The recommended ID value settings for the machine, from left to right, are: 1P, 2P, 3P, 4P. Enter **【Main Menu】** → **【2 System Setting】** → **【2-2 Connection Setting】**, and the screen will display as below:

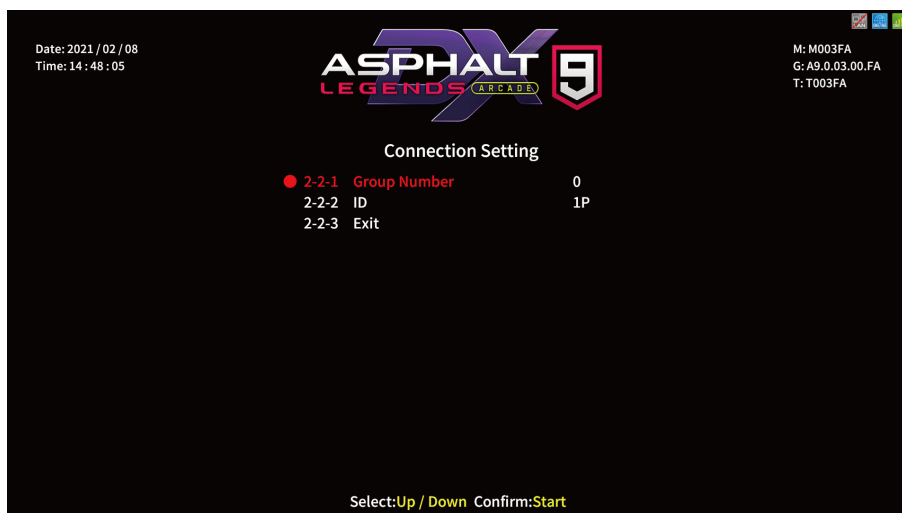

Use the **【Up】** button and **【Down】** button move the cursor and press the **【Start】** button to the sub menu.

Choose the **【2-2-1 Group Number】**, then press the **【Start】** button to setting the group number of the cabinet.

Choose the **【2-2-2 ID】**, then press the **【Start】** button to setting the ID of the cabinet. When completed, move the cursor to **【2-2-3 Exit】**, then press the **【Start】** button to return to the page of **【System Setting】**.

4.6.3 Country Setting

In the page of **【Country Setting】** , you can set your current location.
Enter **【Main Menu】** → **【2 System Settings】** → **【2-3 Country Setting】** , and the screen will display as below:



Use the **【Up】** , **【Down】** , **【Left】** , **【Right】** button move the cursor and press the **【Start】** button to setting Country.

After your preferred setting is chosen, press the **【Start】** button, and return to **【System Setting】** .

4.6.4 Store Setting

In the page of **【Store Setting】** , you can set your Store.

Enter **【Main Menu】** → **【2 System Setting】** → **【2-4 Store Setting】** , and the screen will display as below:



Use the **【Up】** , **【Down】** , **【Left】** , **【Right】** button move the cursor and press the **【Start】** button to confirm the letter you want to input.

When completed, move the cursor to **【OK】** , then press the **【Start】** button to return to the page of **【System Setting】** .

4.6.5 Password Setting

In the page of **【Password Setting】** , you can reset your password.
Enter **【Main Menu】** → **【2 System Setting】** → **【2-5 Password Setting】** , and the screen will display as below:

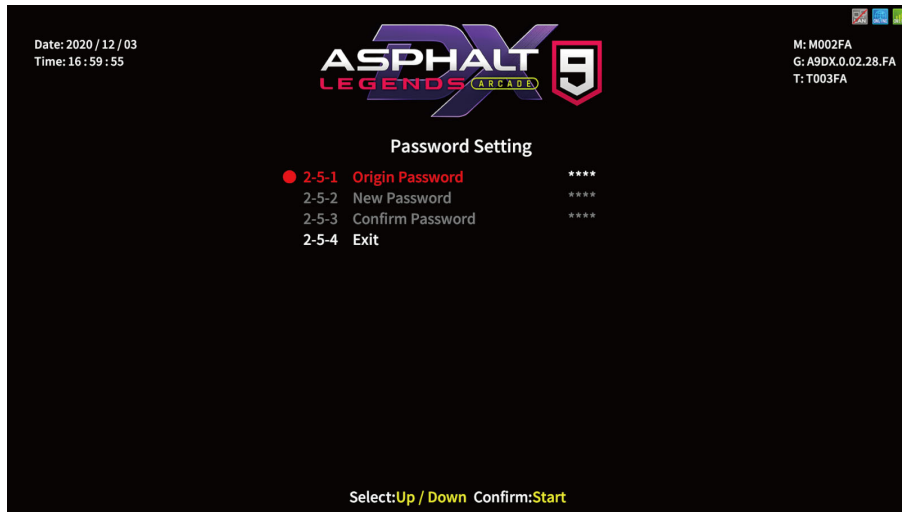

Press the **【Start】** button to enter origin password.
Use the **【Up】** button and **【Down】** button move the cursor and press the **【Start】** button to enter the selected numbers.
After the origin password has been entered, you can continue to enter and confirm the new password.
Once the new password has been entered and confirmed, will appear in green below.

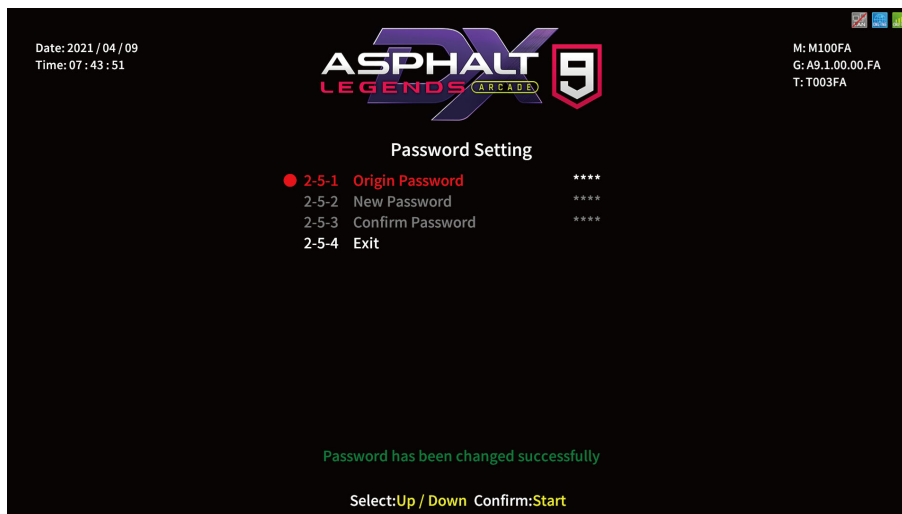

Move the cursor to **【2-5-4 Exit】** and press the **【Start】** button to return to **【System Setting】**

4.6.6 I/O Adjustment

In the page of **I/O Adjustment** , you can adjust the minimum and maximum value of the throttle, brake and steering wheel.

Enter **Main Menu** → **2 System Setting** → **2-6 I/O Adjustment** , and the screen will display as below:

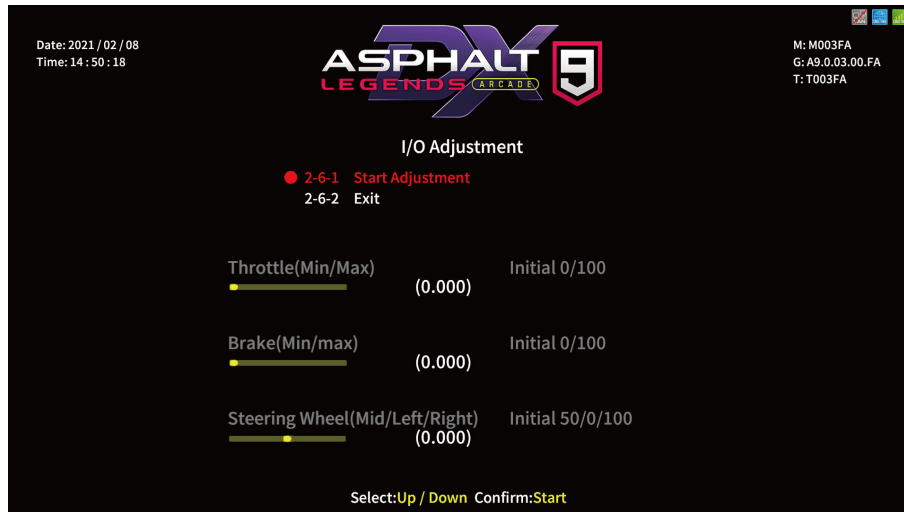

Move the cursor to **2-6-1 Start Adjustment** , then press the **Start** button to start the process.

While adjusting, pictures and tips will appear on the screen.

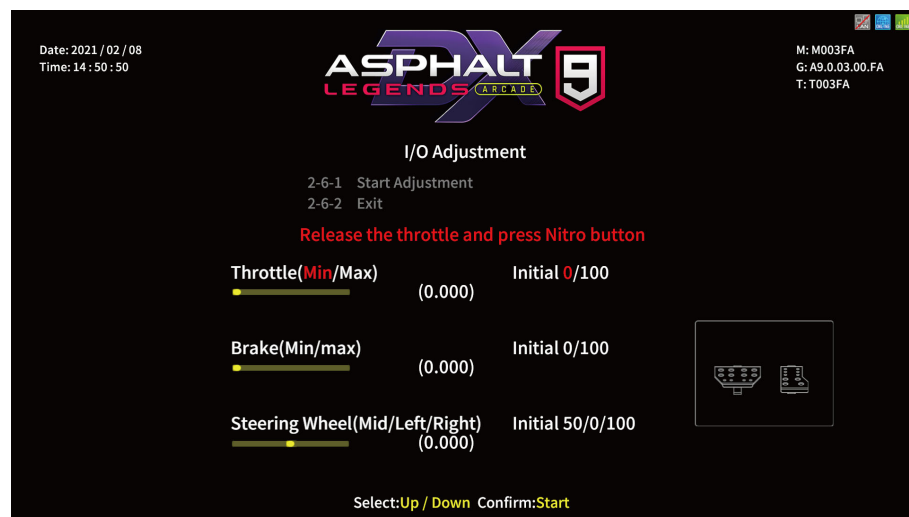

Repeat the above step, and calibrate other values.

After all adjustments are made, an icon of **Adjustment completed** will pop up, then press the **Start** button to return to **System Setting**

4.6.7 Air Spring Adjustment

In the page of **【Air Spring Adjustment】** , you can adjust the minimum and maximum value of the air spring when the motion platform not in function right or malfunction. Enter **【Main Menu】** → **【2 System Setting】** → **【2-7 Air Spring Adjustment】** , and the screen will display as below:



Move the cursor to the **【2-7-1 Start Adjustment】** and press the **【Start】** button to start adjustment



After the adjustment is completed, move the cursor to the **【2-7-2.Exit】** and then press the **【Start】** button to return to **【System Setting】** .

4.6.8 Seatbelt Setting

In the page of **【Seatbelt Setting】** , you can set the seatbelt on or off.

Note: When the setting is on, player must fasten seat belt to activates the motion platform during the game.

Enter **【Main Menu】** → **【2 System Setting】** → **【2-8 Seatbelt Setting】** , and the screen will display as below:

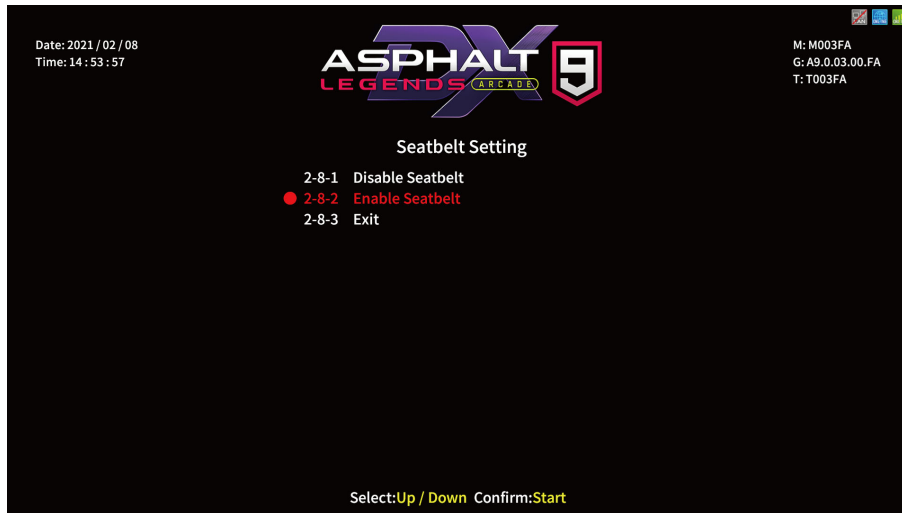

After your preferred setting is chosen, press the **【Start】** button, and return to **【System Setting】** .

Move the cursor to **【2-8-3 Exit】** and press the **【Start】** button to return to **【System Setting】** .

4.7 Game Setting

In the page of **【Game Setting】** , you can set up all related features of the game. Enter **【Main Menu】** → **【3 Game Setting】** , and the screen will display as below:

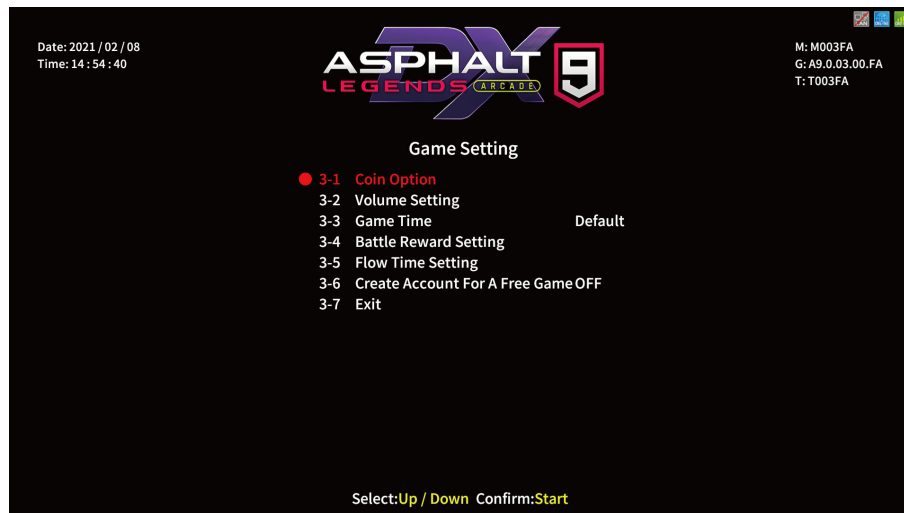

Use the **【Up】** button and **【Down】** button move the cursor and press the **【Start】** button to the sub menu.

After setup is completed, move the cursor to **【3-7 Exit】** , and press the **【Start】** button to return to **【Main Menu】** .

Regarding the detailed description of the sub menu in the **【Game Setting】** refer to the following content.

4.7.1 Coin Option

In the page of **【Coin Option】** , you can select Free play or Coin.

Enter **【Main Menu】** → **【3 Game Setting】** → **【3-1 Coin Option】** , and the screen will display as below:

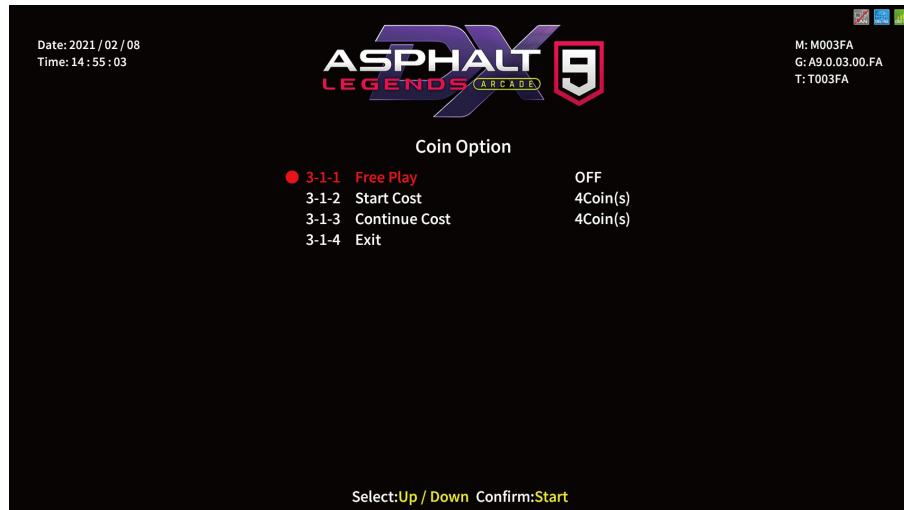

Move the cursor to choose the **【3-1-1 Free Play】** , then press the **【Start】** button to start the process.

Note: When the **【3-1-1 Free Play】** is set to be **【OFF】** , the **【3-1-2 Start Cost】** and the **【3-1-3 Continue Cost】** can be setting.

When the setting process is completed, move the cursor to **【3-1-4 Exit】** ,and press **【Start】** button to return to **【Game Setting】** .

○

4.7.2 Volume Setting

In the page of **【Volume Setting】** , you can determine the start time of daytime and evenings and the corresponding volume.

Enter **【Main Menu】** → **【3 Game Setting】** → **【3-2 Volume Setting】** , and the screen will display as below:

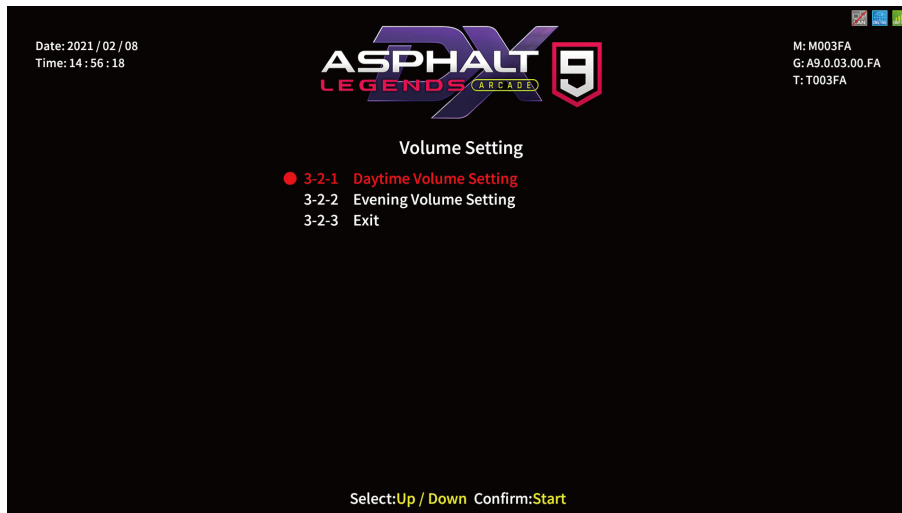

Move the cursor to choose the **【Daytime(Evening) Volume Setting】** , then press the **【Start】** button to enter the page of **【Daytime (Evening) Volume Setting】** , and the screen will display as below:

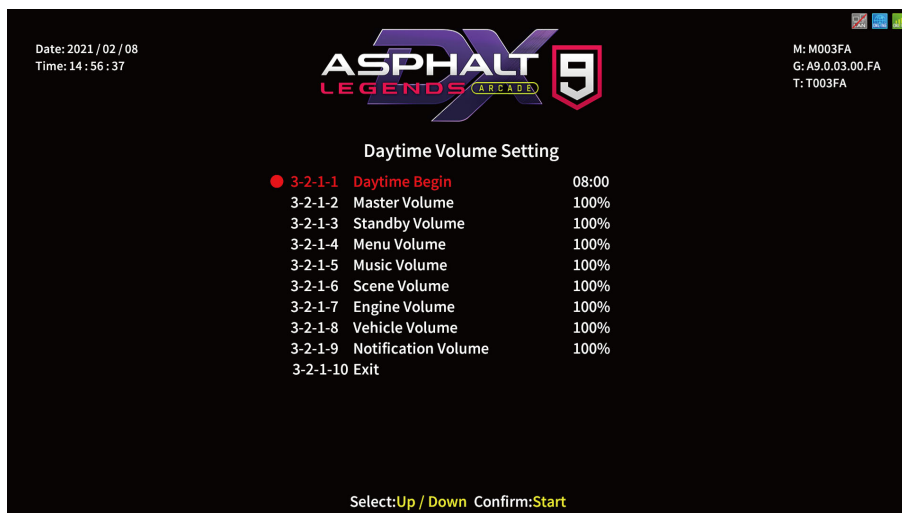

Move the cursor to choose the item, then press the **【Start】** button to start the process.

When the setting process is completed, move the cursor to **【3-2-1-10 Exit】** , and press the **【Start】** button to return to **【Volume Setting】** .

In the page of **【Volume Setting】** , Move the cursor to **【3-2-3 Exit】** , and press the **【Start】** button to return to **【Game Setting】** .

4.7.3 Game Time

In the page of **【Game Time】** , you can determine the game time of Quick Race Mode and Multiplayer Mode.

Enter **【Main Menu】** → **【3 Game Setting】** → **【3-3 Game Time】** , and the screen will display as below:

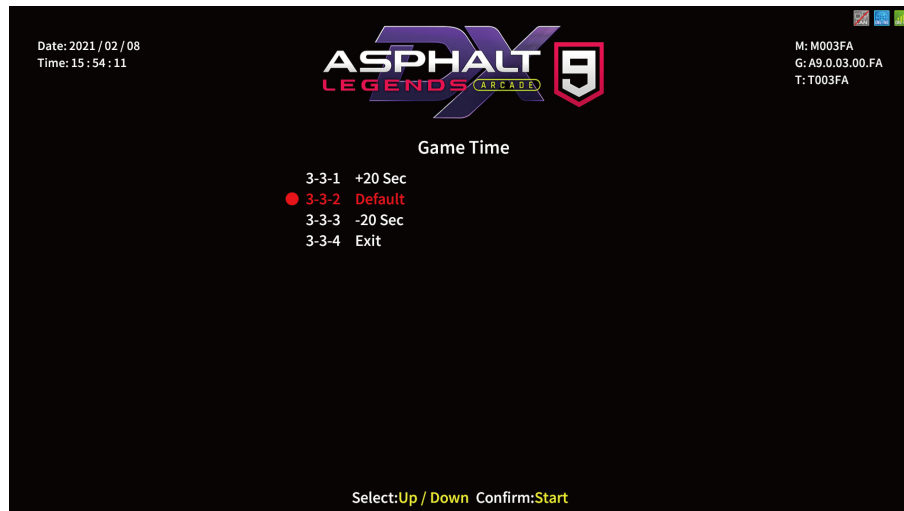

Move the cursor to **【3-3-4 Exit】** and press the **【Start】** button to return to **【Game Setting】** .

4.7.4 Battle Reward Setting

In the page of **【Battle Reward Setting】** , you can turn the setting for Continuous Battle for Championship to On/Off. The setting steps are as follows:

Enter **【Main Menu】** → **【3 Game Setting】** → **【3-4 Battle Reward Setting】** , and the screen will display as below:

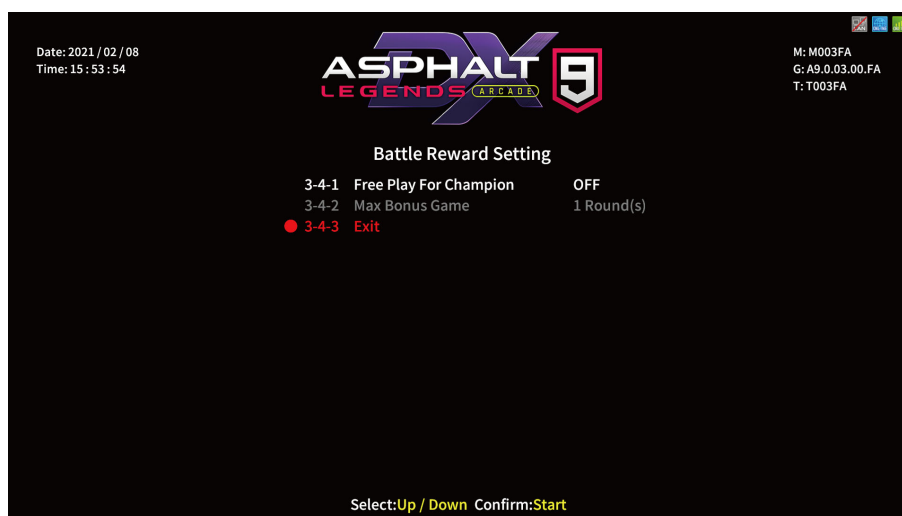

Move the cursor to choose the **【3-4 Battle Reward Setting】** , then press the **【Start】** button to start the process.

Note: **【3-4-1 Battle Reward Setting】** is set to be **【ON】** , the **【3-4-2 Max Bonus Game】** can be setting.

When the setting process is completed, move the cursor to **【3-4-3 Exit】** ,and press **【Start】** button to return to **【Game Setting】** .

4.7.5 Flow Time Setting

In the page of **【Flow Time Setting】** , you can determine the duration of each process:
Enter **【Main Menu】** → **【3 Game Setting】** → **【3-5 Flow Time Setting】** , and the screen will display as below:

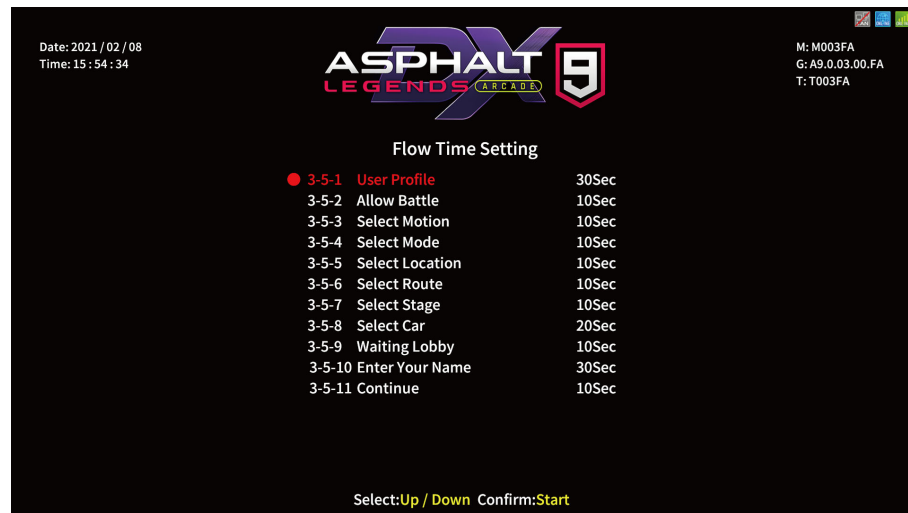

Move the cursor to choose the item, then press the **【Start】** button to start the process.

When the setting process is completed, move the cursor to **【3-5-12 Exit】** , and press the **【Start】** button to return to **【Game Setting】** .

4.7.6 Create Account For A Free Game

In the page of **【Create Account For A Free Game】** , You can determine if players can play the game for free once by creating an Facebook Account.

Enter **【Main Menu】** → **【3 Game Setting】** → **【3-6 Create Account For A Free Game】** , and the screen will display as below:

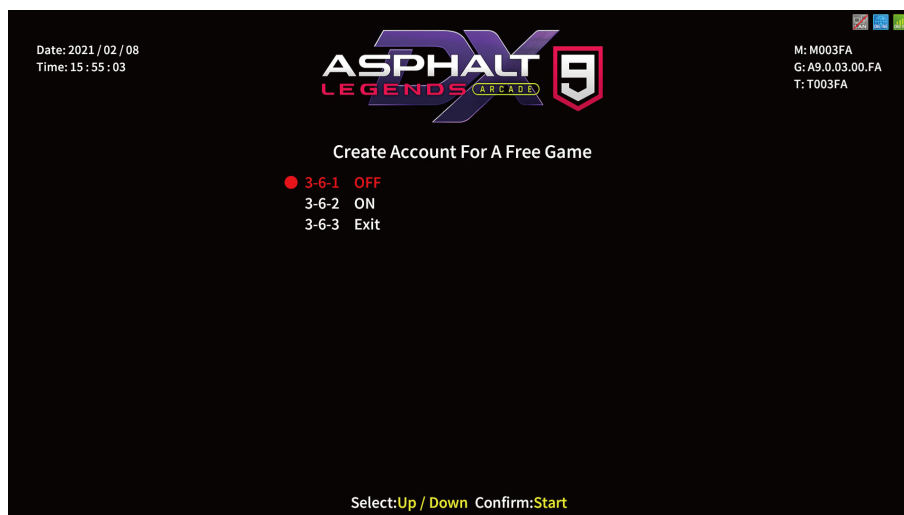

When **【Create Account For A Free Game】** is set to be **【ON】** , The chance to play the game for free can only be used on the game after the player created an account ,and will not be kept if not used.

When the setting process is completed, move the cursor to **【3-6-3 Exit】** , and press the **【Start】** button to return to **【Game Setting】** .

4.8 Income Data

In the page of **【Income Data】** , you can check the daily, monthly and total revenue. Enter **【Main Menu】** → **【4 Income Data】** , and the screen will display as below:

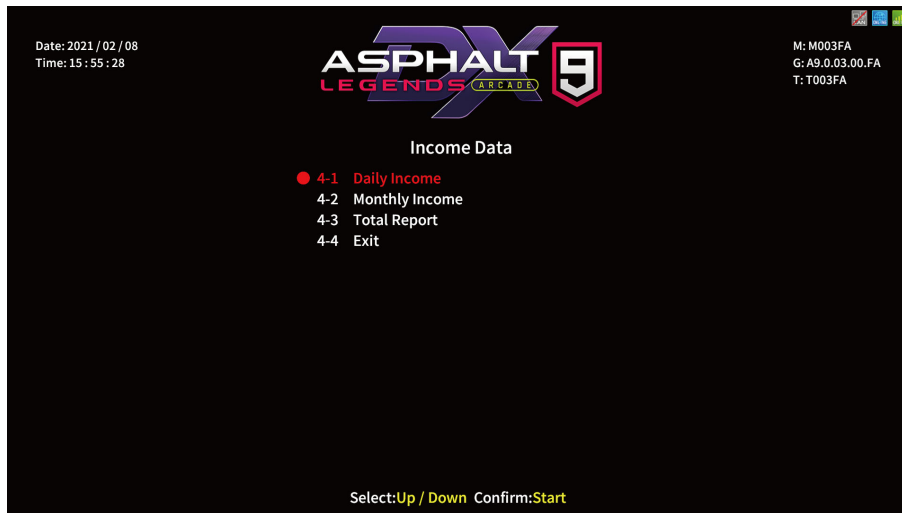

Use the **【Up】** button and **【Down】** button move the cursor and press the **【Start】** button to the sub menu.

Move the cursor to **【4-4 Exit】** and press the **【Start】** button to return to **【Main Menu】** .

Regarding the detailed data of the sub menu in the **【Income Data】** , refer to the following content.

4.8.1 Daily Income

In the page of **【Daily Income】** , you can check the daily revenue of each cabinet. Enter **【Main Menu】** → **【4 Income Data】** → **【4-1 Daily Income】** ,and the screen will display as below:

Date	Coin(s)	Total Game	New Game	Continue	Versus Bonus	Freeplay	Versus	Service	Current Coin(s)	Current Service	Operation Time	Game Time	Avg. Game Time
2021 / 02 / 08	7	0	0	0	0	0	0	0	0	0	00:06:47	00:00:00	00:00:00
2021 / 02 / 05	*29	2	2	0	0	0	0	0	8	0	00:18:08	00:02:04	00:01:02
2021 / 02 / 04	6	0	0	0	0	0	0	0	0	0	00:02:53	00:00:00	00:00:00
2021 / 01 / 29	0	0	0	0	0	0	0	0	0	0	01:31:58	00:00:00	00:00:00
2021 / 01 / 28	8	2	2	0	0	0	0	0	8	0	07:29:38	00:41:14	00:20:37
2021 / 01 / 25	0	0	0	0	0	0	0	0	0	0	00:00:49	00:00:00	00:00:00
2021 / 01 / 23	21	5	4	1	0	0	0	0	20	0	00:16:44	00:11:59	00:02:23
2021 / 01 / 22	42	2	2	0	0	0	0	0	8	0	02:09:43	00:09:44	00:04:52
2021 / 01 / 21	9	0	0	0	0	0	0	0	0	0	00:06:18	00:00:00	00:00:00
2021 / 01 / 20	0	0	0	0	0	0	0	0	0	0	00:40:53	00:00:00	00:00:00
2021 / 01 / 19	84	11	10	1	0	0	0	0	44	0	05:00:23	00:39:49	00:03:37
Average	18	2	20	0	0	0	0	0	8	0	01:36:45	00:09:32	00:04:46

Select:Up / Down Exit:Start

Descriptions of each items:

Item	Descriptions
Date	Date of record
Coin(s)	Total number of coins inserted that day
Total Game	Total number of games on that day
New Game	Number of times coins were inserted to start new games that day
Continue	Number of times coins were inserted to continue games that day
Versus Bonus	Total number of winner bonus games on that day
Freeplay	Total number of freeplays on that day
Versus	Total number of versus games on that day
Service	Total number of service buttons used that day
Current Coin(s)	Actual number of coins deducted that day
Current Service	Actual number of Service deducted that day
Operation Time	The total time the machine was on that day
Game Time	Total game time of that day
Avg. Game Time	Average game time of that day Calculation formula: Game Time/Total Game

Use the **【Up】** button and **【Down】** button to move the page, and press the **【Start】** button to return to **【Income Data】** .

4.8.2 Monthly Income

In the page of **【Monthly Income】**, you can check the monthly revenue of each cabinet. Enter **【Main Menu】** → **【4 Income Data】** → **【4-2 Monthly Income】**, and the screen will display as below:

Date	Coin(s)	Total Game	New Game	Continue	Versus Bonus	Freeplay	Versus	Service	Current Coin(s)	Current Service	Operation Time	Game Time	Avg. Game Time
2021 / 02	*42	2	2	0	0	0	0	0	8	0	00:27:50	00:02:04	00:01:02
2021 / 01	164	20	18	2	0	0	0	0	80	0	17:16:31	01:42:47	00:05:08
Average	103	11	20	1	0	0	0	0	44	0	08:52:10	00:52:26	00:04:46

Select:Up/Down Exit:Start

Descriptions of each items:

Item	Descriptions
Date	Date of record
Coin(s)	Total number of coins inserted that month
Total Game	Total number of games on that month
New Game	Number of times coins were inserted to start new games that month
Continue	Number of times coins were inserted to continue games that month
Versus Bonus	Total number of winner bonus games on that month
Freeplay	Total number of freeplays on that month
Versus	Total number of versus games on that month
Service	Total number of service buttons used that month
Current Coin(s)	Actual number of coins deducted that month
Current Service	Actual number of Service deducted that month
Operation Time	The total time the machine was on that month
Game Time	Total game time of that month
Avg. Game Time	Average game time of that month Calculation formula: Game Time/Total Game

Use the **【Up】** button and **【Down】** button to move the page, and press the **【Start】** button to return to **【Income Data】**.

4.8.3 Total Report

In the page of **【Total Report】** , you can check the total revenue of each cabinet.
Enter **【Main Menu】** → **【4 Income Data】** → **【4-3 Total Report】** ,and the screen will display as below:

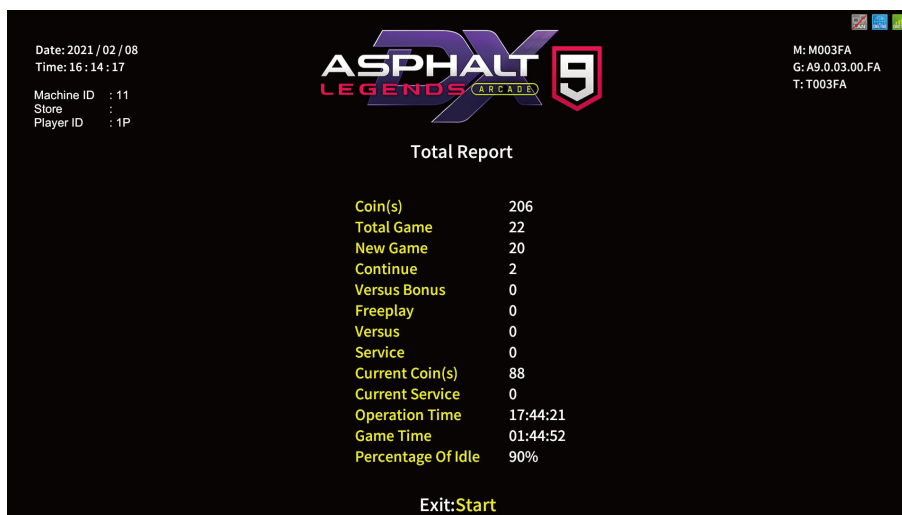

Descriptions of each items:

Item	Descriptions
Coin(s)	Total number of coins deducted overall
Total Game	Total number of games overall
New Game	Number of times coins were inserted to start new games in total
Continue	Number of times coins were inserted to continue games in total
Versus Bonus	Total number of winner bonus games overall
Freeplay	Total number of freeplays overall
Versus	Total number of versus games overall
Service	Total number of Service overall
Current Coin(s)	Actual number of coins deducted overall
Current Service	Number of service buttons used in total
Operation Time	The total time the machine was on overall
Game Time	Total game time overall
Percentage Of Idle	Percentage of time the machine was sitting idle after it was switched on Calculation formula: (Operation time - Game Time)/ Operation time x100%

Press the **【Start】** button to return to **【Income Data】** .

4.9 System Reset

In the page of **【System Reset】** , you can delete the income data or set the system to the default setting.

Enter **【Main Menu】** → **【5 System Reset】** , and the screen will display as below:

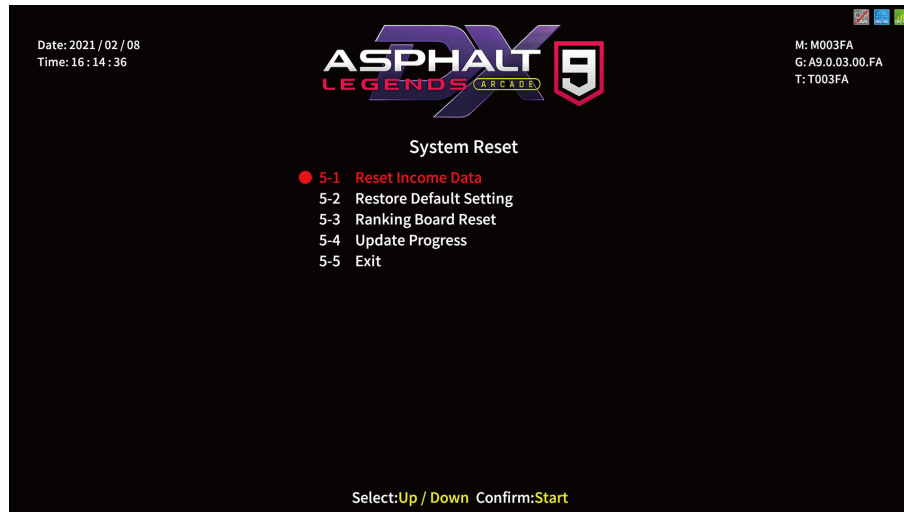

Use the **【Up】** button and **【Down】** button move the cursor and press the **【Start】** button to the sub menu.

After setup is completed, move the cursor to **【5-5 Exit】** , and press the **【Start】** button to return to **【Main Menu】** .

Regarding the detailed descriptions of the sub menu in **【System Reset】** , refer to the following content.

4.9.1 Reset Income Data

In the page of **【Reset Income Data】** , you can delete the data of daily income and monthly income.

Enter **【Main Menu】** → **【5 System Reset】** → **【5-1 Reset Income Data】** ,and the screen will display as below:

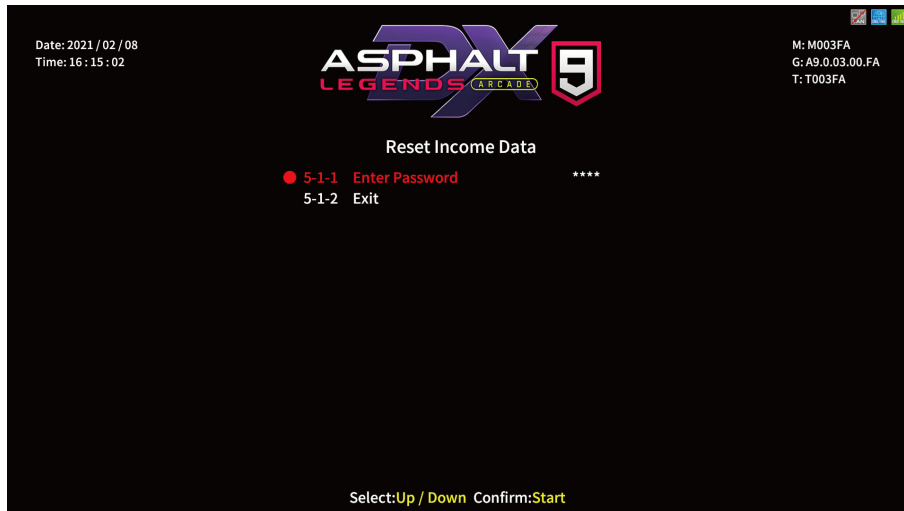

Move the cursor to choose **【5-1-1 Enter Password】** , and press the **【Start】** button to start entering the set password. Or you can select **【5-1-2 Exit】** to exit the page and return to the **【5 System Reset】** .

To change, Use the **【Up】** button and **【Down】** button .Then press the **【Start】** button to enter the selected numbers.

After the password has been entered, the following screen will be displayed:

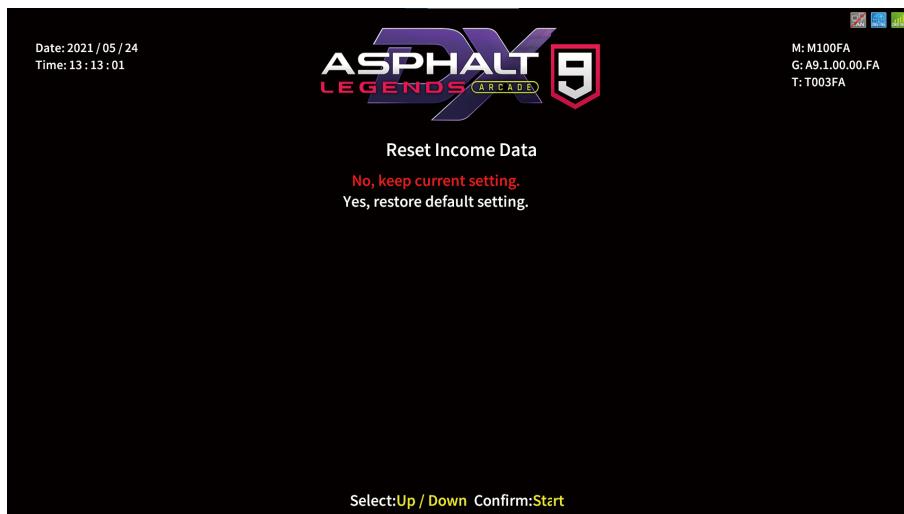

Move the cursor to **【Yes, restore default setting.】** , and press the **【Start】** button to Reset Income Data. If Clear was successful the words **【Reset Complete】** will appear in red.

Note: This function cannot delete the data of **【Total Income】** .

When **【No, keep current setting.】** is selected, the screen will automatically direct to the page of **【5 System Reset】** .

4.9.2 Restore Default Setting

In the page of **【Restore Default Setting】** , you can set the system to the default setting. Enter **【Main Menu】** → **【5 System Reset】** → **【5-2 Restore Default Setting】** ,and the screen will display as below:

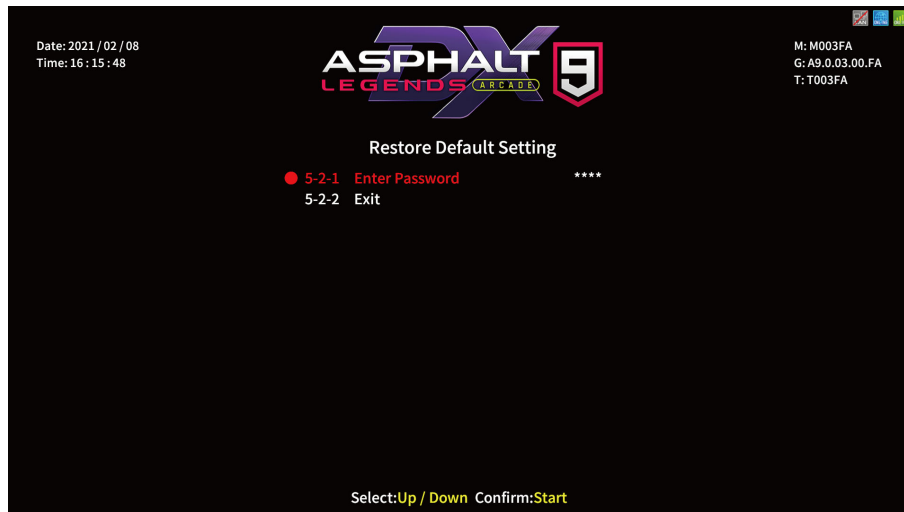

Move the cursor to choose **【5-2-1 Enter Password】** , and press the **【Start】** button to start entering the set password. Or you can select **【5-2-2 Exit】** to exit the page and return to the **【5 System Reset】** .

To change, Use the **【Up】** button and **【Down】** button .Then press the **【Start】** button to enter the selected numbers.

After the password has been entered, the following screen will be displayed:

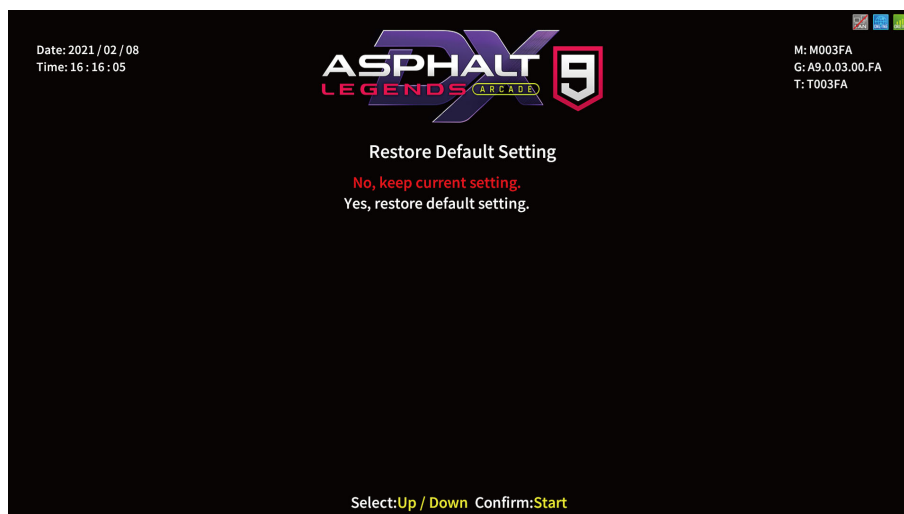

Move the cursor to **【Yes, restore default setting.】** , and press the **【Start】** button to Reset Default Data. If Clear was successful the words **【Reset Complete】** will appear in green.

When **【No, keep current setting.】** is selected, the screen will automatically direct to the page of **【5.System Reset】** .

The settings below will be reset to default:

System Setting: Connection Setting, Country Setting, Store Setting, Password Setting, I/O Adjustment, Air Spring Adjustment, Seatbelt Setting.

Game Setting: Coin Option, Volume Setting, Game Time, Battle Reward Setting, Flow Time Setting, Create Account For A Free Game.

Note: please refer to section 4.10 setting defaults for more details.

4.9.3 Ranking Board Reset

In the page of **【Ranking Board Reset】** , you can reset the ranking board record to the default setting.

Enter **【Main Menu】** → **【5 System Reset】** → **【5-3 Ranking Board Reset】** ,and the screen will display as below:

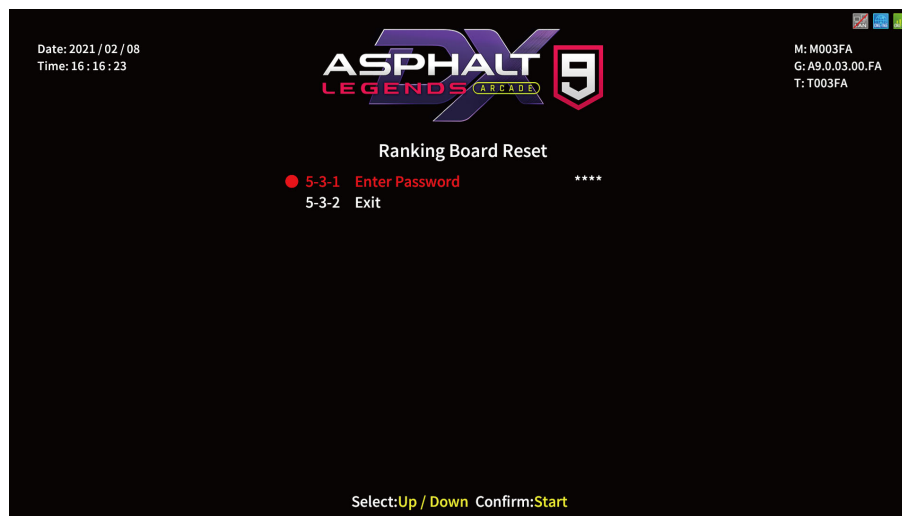

Move the cursor to choose **【5-3-1 Enter Password】** , and press the **【Start】** button to start entering the set password. Or you can select **【5-3-2 Exit】** to exit the page and return to the **【5 System Reset】** .

To change, Use the **【Up】** button and **【Down】** button .Then press the **【Start】** button to enter the selected numbers.

After the password has been entered, the following screen will be displayed:

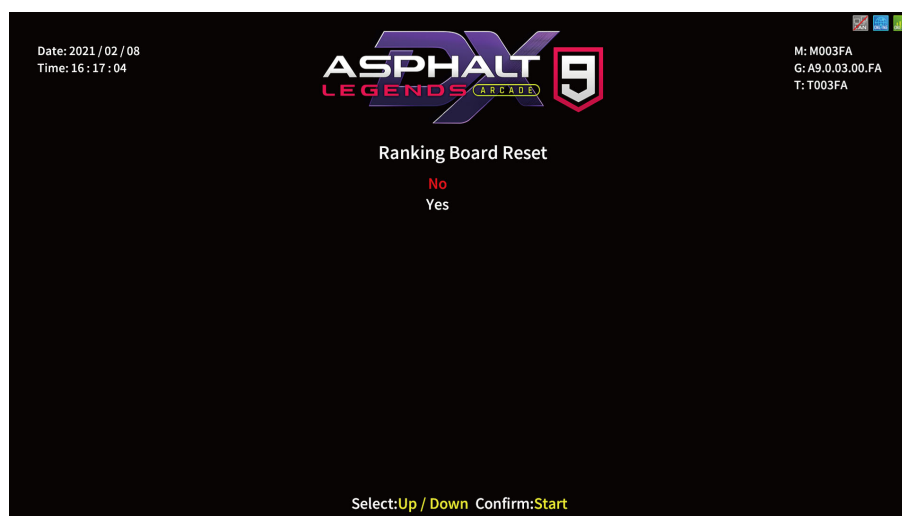

Move the cursor to **【Yes】** , and press the **【Start】** button to Reset Income Data. If Clear was successful the words **【Reset Complete】** will appear in green.

When **【No】** is selected, the screen will automatically direct to the page of **【5 System Reset】** .

Note: Only Local Ranking Board Will be reset.

4.9.4 Update Progress

In the page of **【Update Progress】** , you can check it there is an update for the latest version. The set-up steps are as follows.

Enter **【Main Menu】** → **【5 System Reset】** → **【5-4 Update Progress】** ,and the screen will display as below:

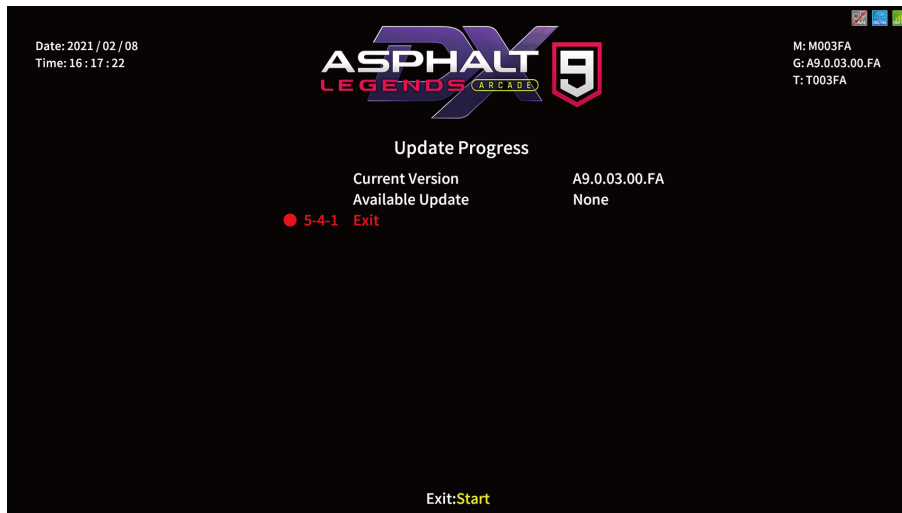

Enter the page to check if you have the latest version, press the Start key to confirm and return to the previous menu.

4.10 Game Setting Defaults

Name of the Setting	Default Setting	Available Setting
Coin Option→Free Play	OFF	OFF, ON
Coin Option→Start Cost	6	1,2,3...20
Coin Option→Continue Cost	6	1,2,3...20
Volume Setting→Daytime Volume Setting→Daytime Begin	8:00	00:00~23:00(set by the hour)
Volume Setting→Evening Volume Setting→Evening Begin	18:00	00:00~23:00(set by the hour)
VolumeSetting→Daytime/Evening Volume Setting→Master Volume	100%	0%,10%,20%...100%
VolumeSetting→Daytime/Evening Volume Setting→Standby Volume	100%	0%,10%,20%...100%
VolumeSetting→Daytime/Evening Volume Setting→Menu Volume	100%	0%,10%,20%...100%
VolumeSetting→Daytime/Evening Volume Setting→Music Volume	100%	0%,10%,20%...100%
VolumeSetting→Daytime/Evening Volume Setting→Scene Volume	100%	0%,10%,20%...100%
VolumeSetting→Daytime/Evening Volume Setting→Engine Volume	100%	0%,10%,20%...100%
VolumeSetting→Daytime/Evening Volume Setting→Vehicle Volume	100%	0%,10%,20%...100%
Daytime/Evening Volume Setting→Notification Volume	100%	0%,10%,20%...100%
Game Time	Default	+20 Sec, Default, -20 Sec
Battle Reward Setting→Free Play For Champion	OFF	OFF, ON
Battle Reward Setting→Max Bonus Game	1	1,2,3...10, Unlimited
Flow Time Setting→User Profile	30	1,2,3...60
Flow Time Setting→Allow Battle	10	1,2,3...30
Flow Time Setting→Select Motion	10	1,2,3...30
Flow Time Setting→Select Mode	10	1,2,3...30
Flow Time Setting→Select Location	10	1,2,3...30
Flow Time Setting→Select Route	10	1,2,3...30
Flow Time Setting→Select Stage	10	1,2,3...30
Flow Time Setting→Select Car	20	1,2,3...30
Flow Time Setting→Waiting Lobby	10	1,2,3...30
Flow Time Setting→Enter Your Name	30	1,2,3...30
Flow Time Setting→Continue	10	1,2,3...30
Create Account For A Free Game	OFF	OFF, ON
Seatbelt Setting	Enable	Disable , Enable
Password Setting	0000	0000~9999

5. Maintenance and Service

5.1 Maintenance and service

Even though the machine works normally for a long time, the fault will occur. Therefore, please perform routine check and maintenance concerning the following to ensure a long-term use.

■ External Inspection

- Stick “Warning” stickers correctly, keep it legible.
- Firmly tighten the bolt for each adjuster.
- Tighten screws for speaker assembly.
- Tighten the signboard firmly.
- Check if the screws fixing the parts loose.
- Check if the connectors loose or missing.

■ Operation Inspection (With power on)

- Sound is normally emitted from the speakers or not.
- Fluorescent lamps and LED and button lamps light up or not
- Coin acceptor works properly or not.
- Lifting and falling devices work properly or not.
- YZ sensor works properly or not.

After completing all the checks, operate the game again and check the above items with full care!

■ Servicing (conducted by a technician only)

- Cut off the main power supply to avoid injury or electric shock when performing maintenance.
- Please contact our service center when performing any work that is not specified in this Manual, and follow the instruction provided by the service center.
- For consumables and spare parts (including screws), please use products specified by Wahlap Technology.
- Even though the main power is cut off, there is still high temperature and high pressure in the power board and the monitor. The person will be burnt or get an electric shock if he touches such parts. Please pay full attention to avoid contact.
- Be sure to cut off the main power when you alter a spare part or unplug a connector.

5.2 Part Replacement

5.2.1 Repair and replacement of coin box and the light bar of cashbox

[Replace the coin box]

1. Open the coin door with the key;
2. Remove the screws fixing the coin device, remove and replace the coins device (pay attention to the connection of wires);
3. Assemble in reverse order.

[Replace the light bar of cashbox]

1. Open the coin door with the key;
2. Remove the nuts fixing the light bar of cashbox, remove and replace the light bar of cashbox (pay attention to the connection of wires);
3. Assemble in reverse order.

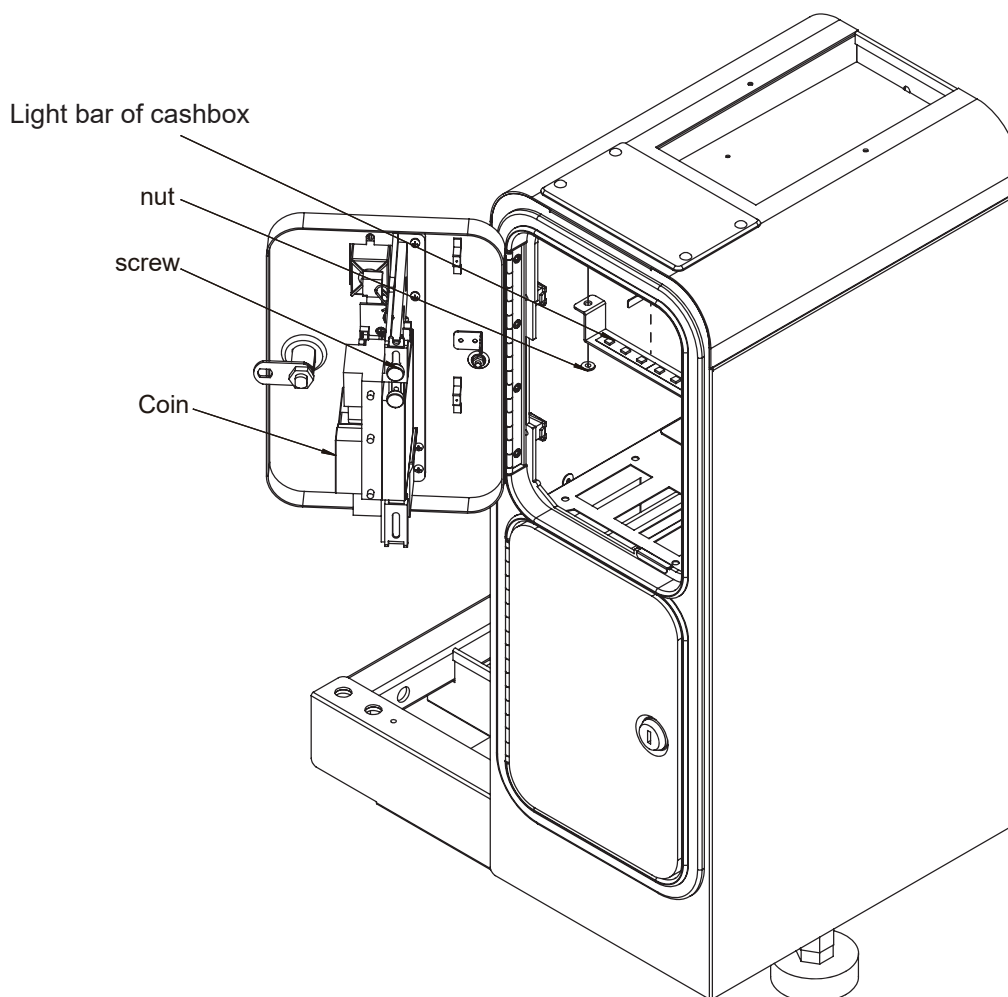

5.2.2 Repair and replacement of light bar for exhaust tube and 5050 soft strip light

[Replace light board of exhaust tube]

1. Remove the screws fixing the plastic-forming tail fin, and then remove the screws fixing the exhaust pipe assembly (pay attention to the connection of wires);
2. Finally, remove the screws fixing the light board of exhaust tube, remove and replace the light board of exhaust tube;
3. Assemble in reverse order.

[Replace 5050 soft strip light (WS2815 chip)]

1. Remove the screws fixing the plastic-forming tail fin,
2. Use a screwdriver to pry out the 5050 soft strip light, remove and replace the 5050 soft strip light (pay attention to the connection of wires);
3. Assemble in reverse order.

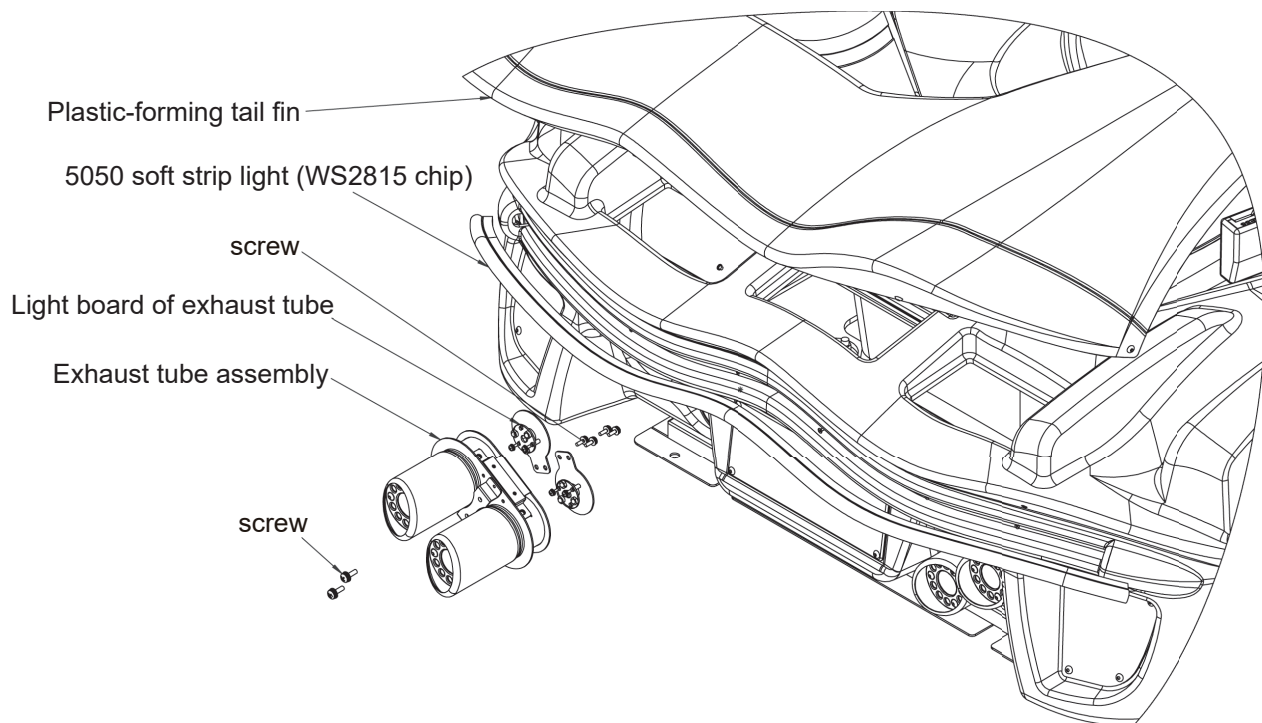

5.2.3 Maintenance and replacement of (film) switch buttons and light board (LED) of button

[Replace (film) switch button]

1. Remove the screws fixing acrylic on the left side of console, and then remove the screws fixing (film) switch button;
2. Remove and replace the (film) switch button (pay attention to the connection of wires);
3. Assemble in reverse order.

[Replace light board (LED) of button]

1. Remove the screws fixing acrylic on the right side of console, and then remove the screws fixing light board (LED) of button;
2. Remove and replace the light board (LED) of button (pay attention to the connection of wires);
3. Assemble in reverse order.

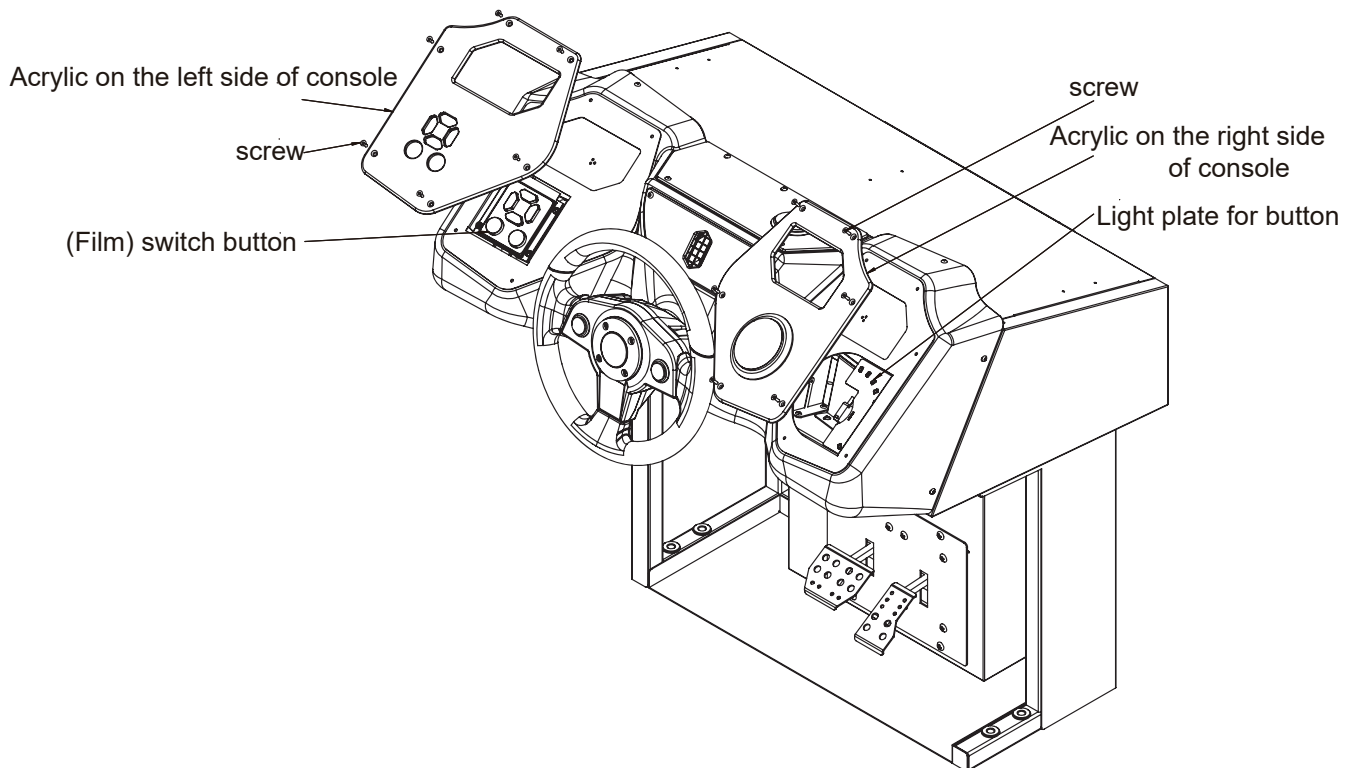

5.2.4 Repair and replacement for I/O control panel and motor control panel

[Replace I/O control panel]

1. Remove the screws fixing the cover of console, and then remove the screws of the I/O control panel;
2. Remove and replace the I/O control panel (pay attention to the connection of wires);
3. Assemble in reverse order.

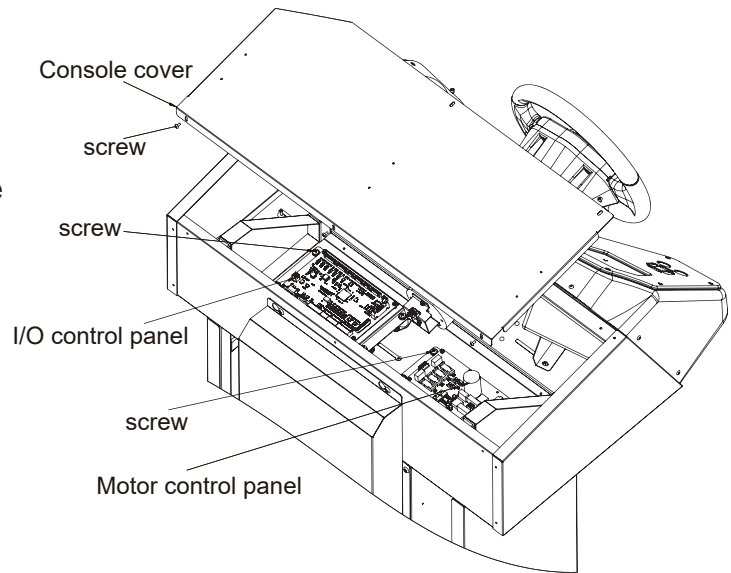

[Replace motor control panel]

1. Remove the screws fixing the cover plate of console, and then remove the screws of the motor control panel;
2. Remove and replace the motor control panel (pay attention to the connection of wires);
3. Assemble in reverse order.

5.2.5 Maintenance and replacement of woofer

1. Remove the screws fixing the back cover of the woofer, and then remove the screws fixing the console woofer assembly;
2. Finally remove the screw of the woofer, remove and replace the woofer (pay attention to the connection of wires);
3. Assemble in reverse order.

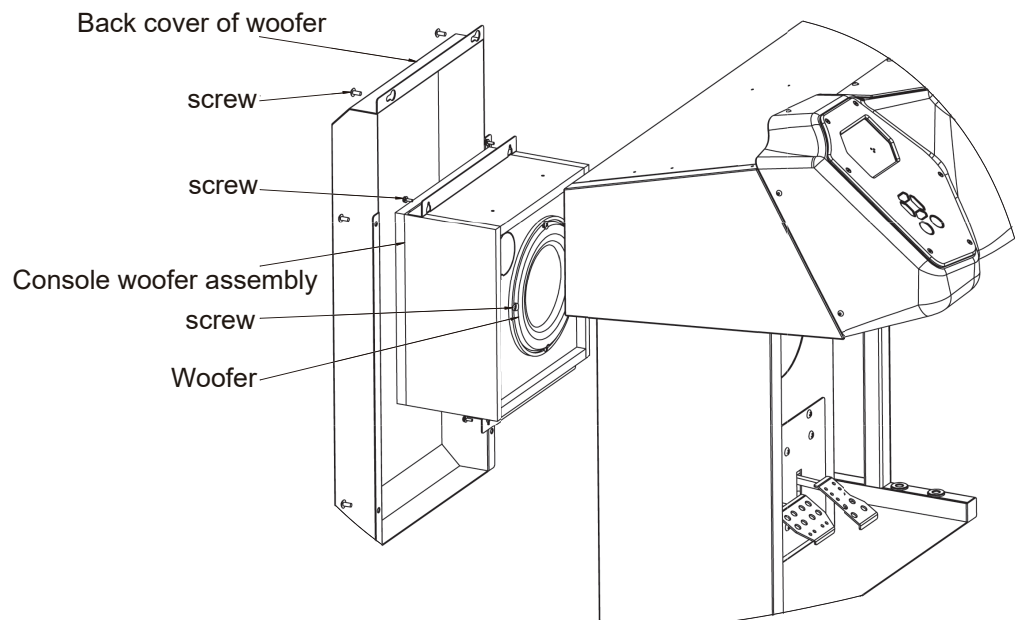

5.2.6 Maintenance and replacement of 5050 soft strip light (L=800mm) and 5050 soft strip light (LPD6803 chip)

Refer to the instructions in assembly drawing A9DX-0000000, remove the top light box assembly (note the connection of wires);

[Replace 5050 soft strip light(L=800mm)]

1. Remove the screws fixing the background decoration components of light box, and then remove the screws on protection cover of light box;
2. Finally, remove the nut fixing the PVC board for light, remove and replace the 5050 soft strip light (pay attention to the connection of wires);
3. Assemble in reverse order.

[Replace the 5050 soft strip light (LPD6803 chip)]

1. Remove the screws fixing the fixing plate for decorative light bar, and then remove the screws fixing the cover plate of decorative light bar;
2. Remove and replace the 5050 soft strip light (LPD6803 chip) (pay attention to the connection of wires);
3. Assemble in reverse order.

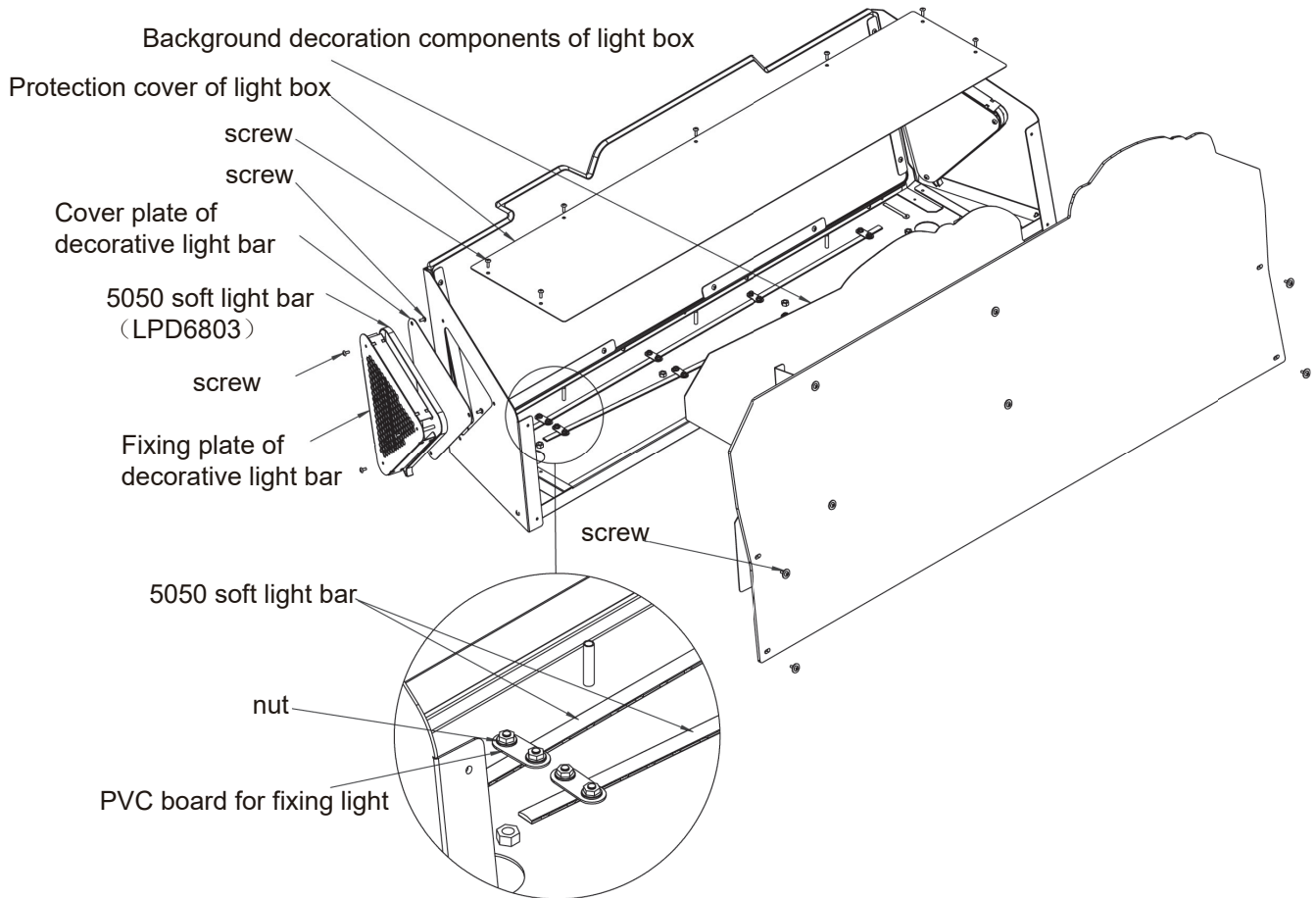

5.2.7 Repair and replacement of 5050 soft strip light and LCD

[Replace 5050 soft strip light]

1. Remove the screws fixing the top service door, and then remove the screws of light box & light bar assembly;
2. Remove and replace the 5050 soft strip light (pay attention to the connection of wires);
3. Assemble in reverse order.

[Replace the LCD]

1. Remove the screws fixing the top service door, and then remove the screws of the LCD component;
3. Assemble in reverse order.
2. Finally remove the screws of the LCD, remove and replace the LCD (pay attention to the connection of wires);

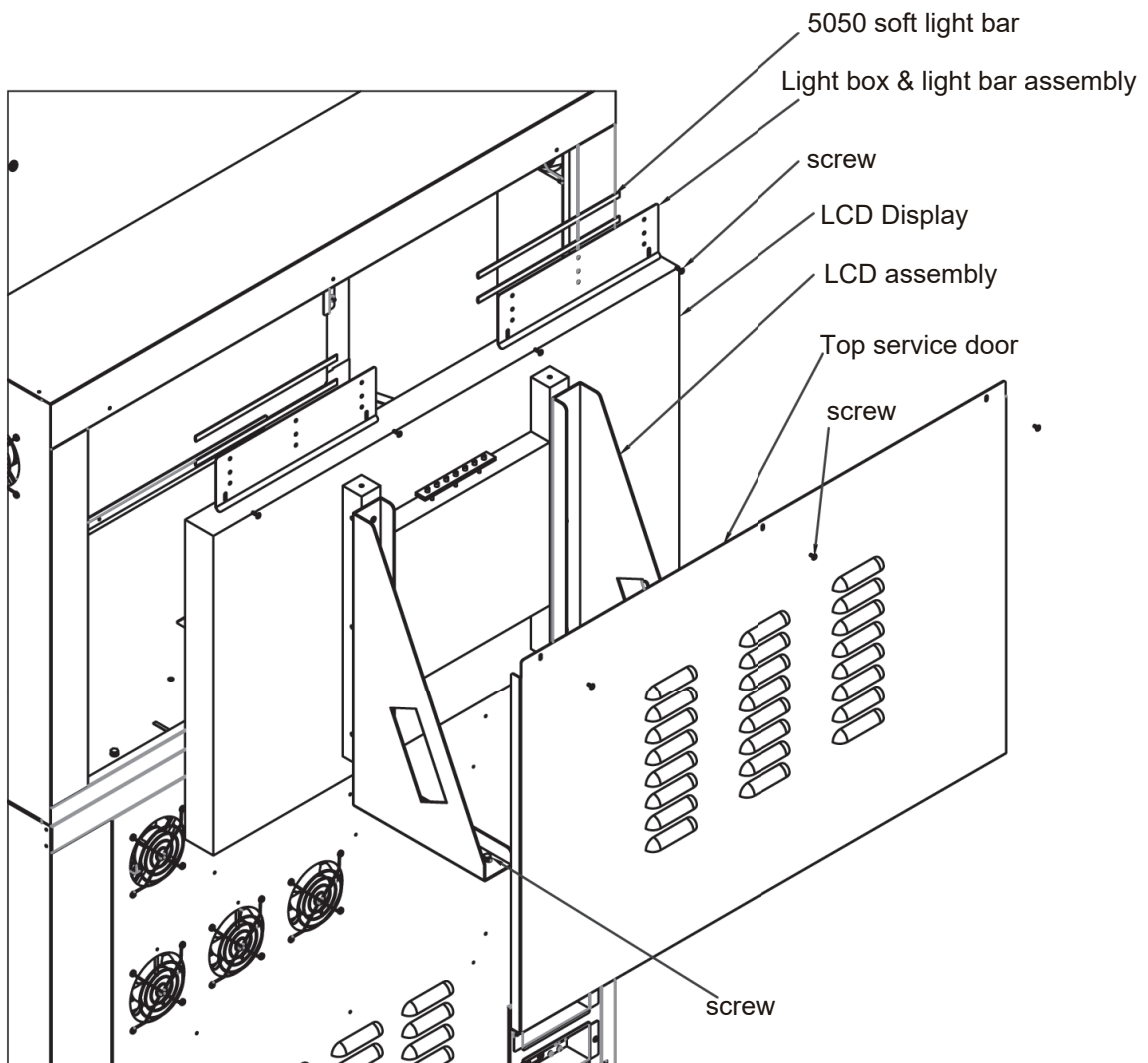

5.2.8 Maintenance and replacement of main machine

1. Open the service door assembly with a key, and then remove the screws fixing the main machine assembly;
2. Finally, remove the screws of the main machine, remove and replace the main machine (pay attention to the connection of wires);
3. Assemble in reverse order

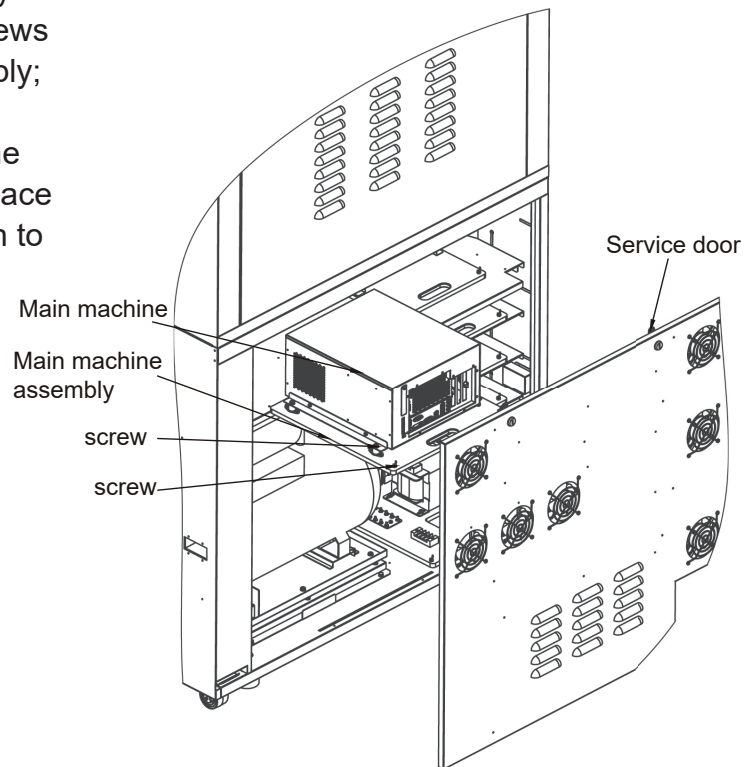

5.2.9 Maintenance and replacement of air compressor

1. Open the service door assembly with key, and then remove the screws fixing the air compressor assembly;
2. Finally, remove the screws of the air compressor, remove and replace the air compressor (pay attention to the connection of wires);
3. Assemble in reverse order.

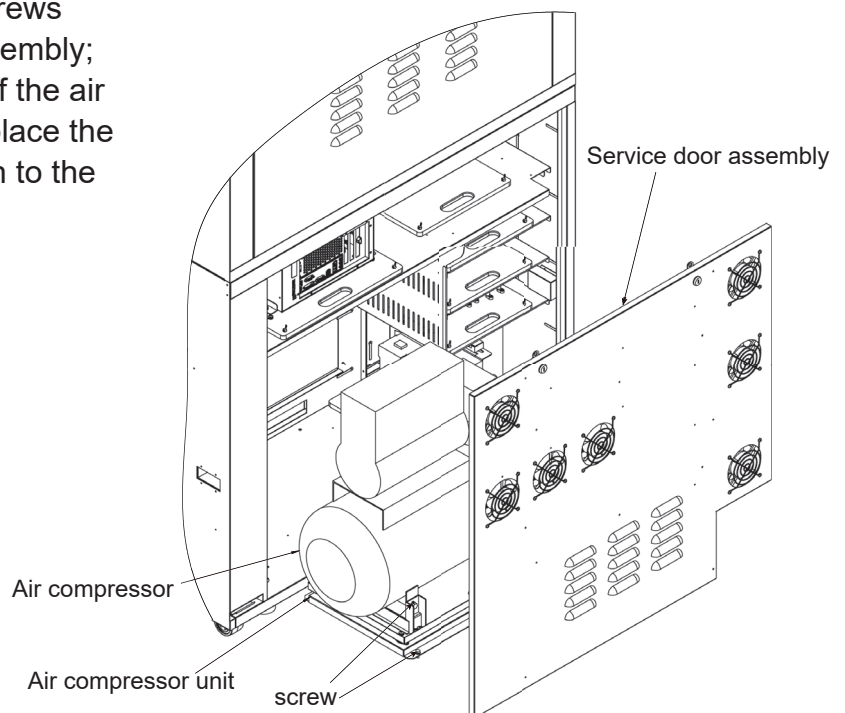

5.2.10 Maintenance and replacement of filters and fluid control valves

[Replace the filter]

1. Open the service door assembly with key, and then remove the nut fixing the filter assembly;
2. Finally, remove the screw of the filter, remove and replace the filter (pay attention to the connection of wires);
3. Assemble in reverse order.

[Replace the fluid control valve]

1. Open the service door assembly with key, and then remove the nuts of fluid control valve assembly;
2. Finally, remove the screw of the fluid control valve, remove and replace the fluid control valve (pay attention to the connection of wires);
3. Assemble in reverse order.

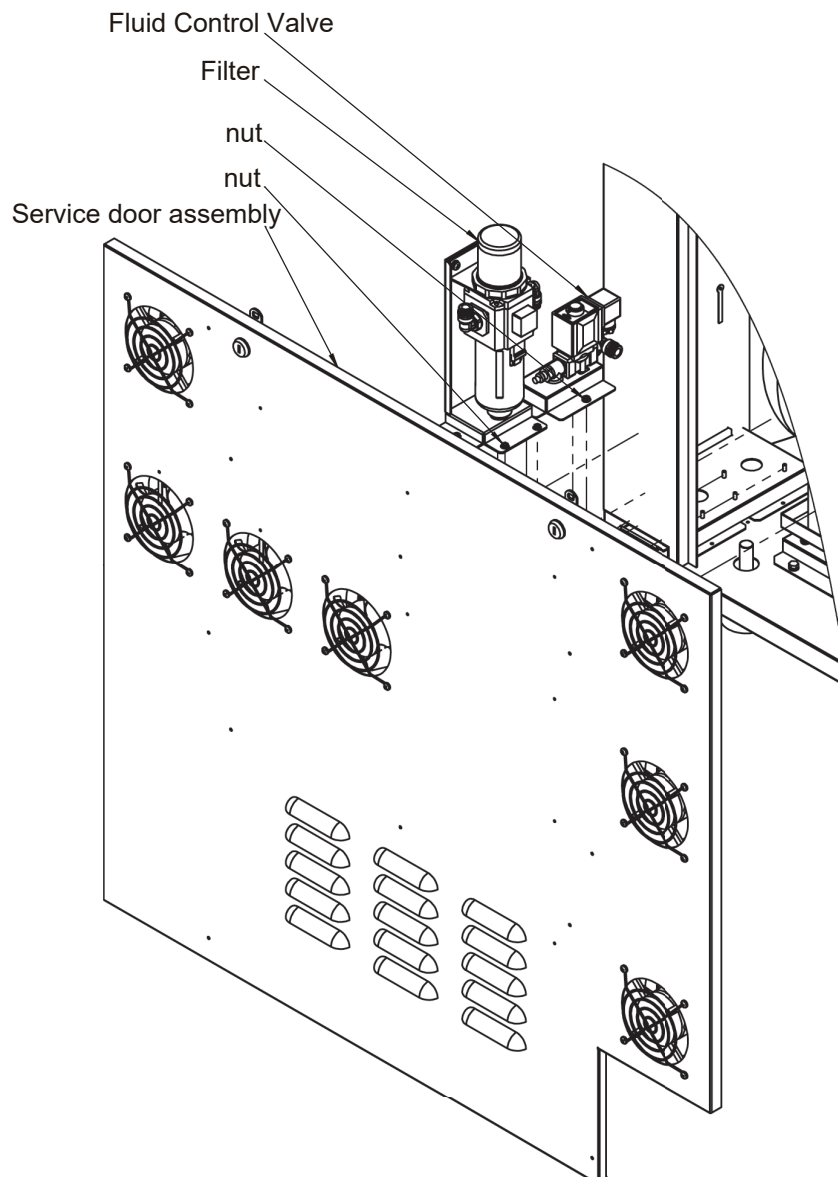

5.2.11 Repair and replace the power box and solenoid valve

[Replace the power box]

1. Remove the screws fixing the platform pedal assembly, and then remove the screws fixing the protection cover of the power box;
2. Finally, remove the screws of the power box, remove and replace the power box (pay attention to the connection of wires);
3. Assemble in reverse order.

[Replace the solenoid valve]

1. Remove the screws fixing the platform pedal assembly, and then remove the screws fixing the solenoid valve assembly;
2. Finally, remove the screw of the solenoid valve, remove and replace the solenoid valve (pay attention to the connection of wires);
3. Assemble in reverse order.

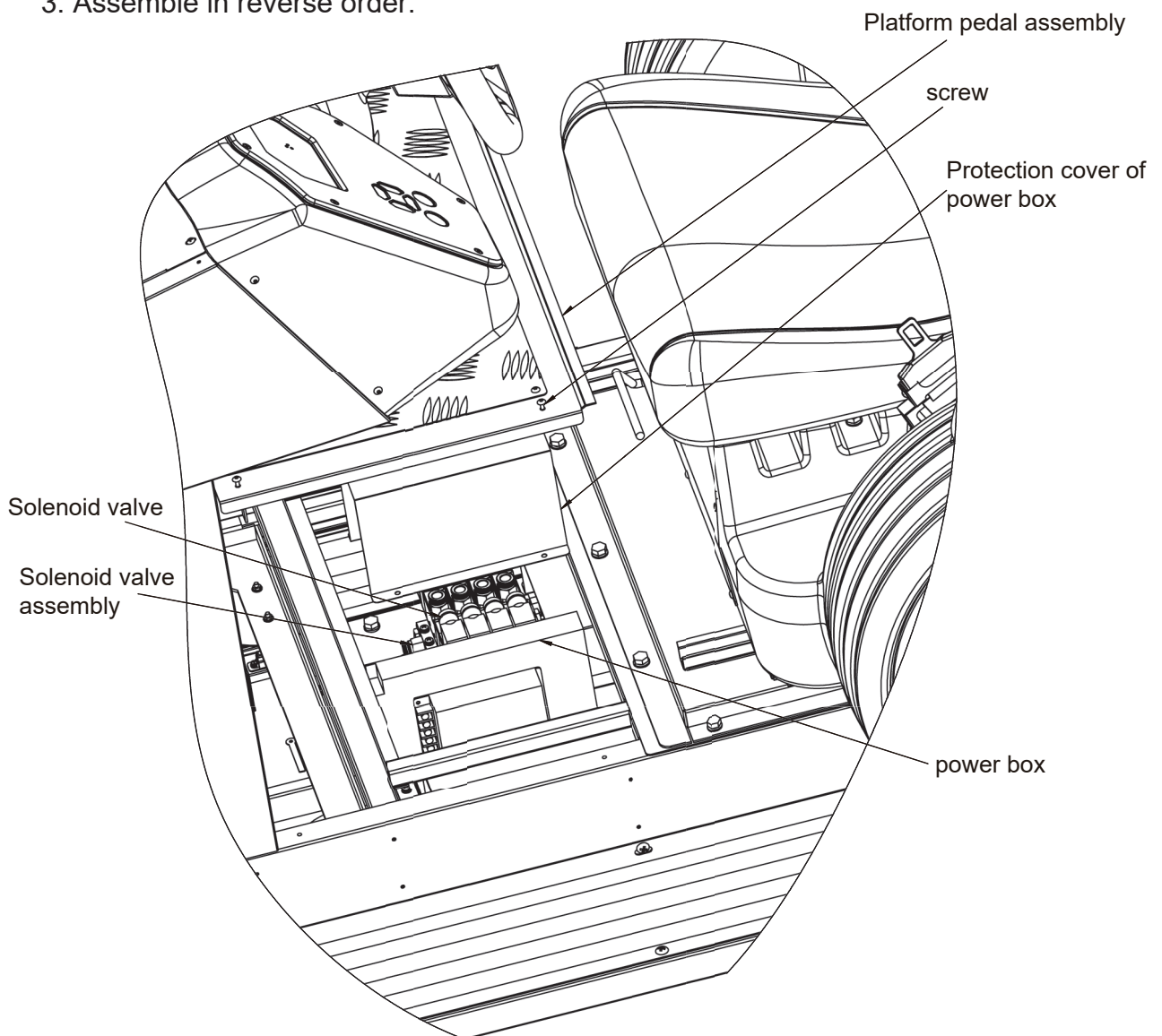

5.2.12 Maintenance and replacement of control panel of air compressor system, and light control pane

[Replace the control panel of the air compressor system]

1. Remove the screws fixing the platform pedal assembly, and then remove the screws of protection cover for I/O board;
2. Finally, remove the screws of the control panel of the air compressor system, remove and replace the control panel of the air compressor system (pay attention to the connection of wires);
3. Assemble in reverse order.

[Replace the light control panel]

1. Remove the screws fixing the platform pedal assembly, and then remove the screws of protection cover for I/O board;
2. Finally, remove the screws of the light control panel, remove and replace the light control panel (pay attention to the connection of wires);
3. Assemble in reverse order.

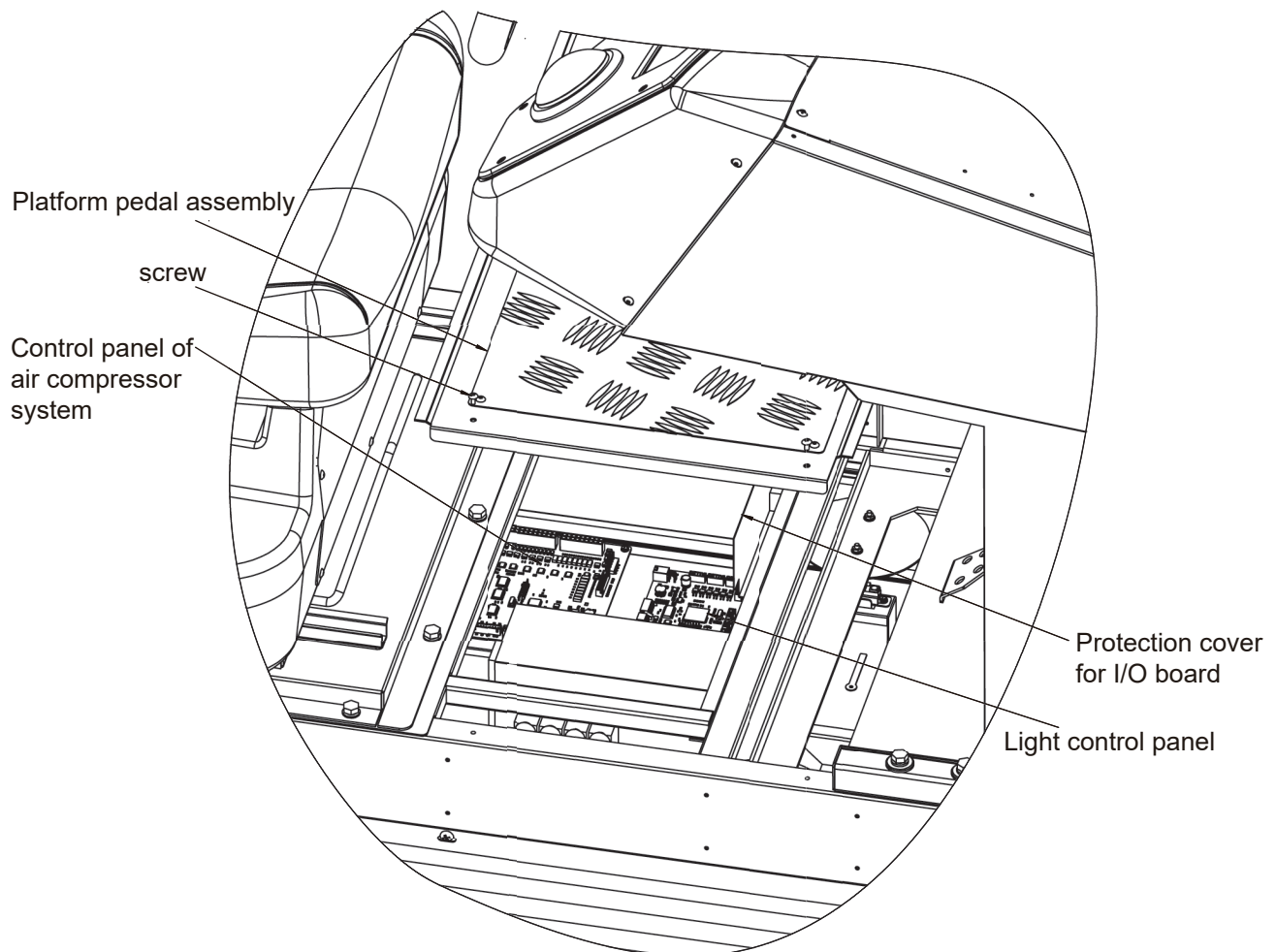

Note: For the unlisted items, refer to Assembling Drawing in chapter 6.

5.3 Air Compressor Maintenance

WARNING

1. The maintenance and examination of the air compressor must be operated by certified technician.
2. In order to avoid electric shock, accidents or injuries of operator, please make sure to cut off the power switch of the air compressor.
3. Even after the power switch is off, the air compressor still remains in high temperature. In order to avoid burns or any danger, please leave the air compressor for at least 1 hour before any maintenance or examination of the air compressor is carried out.

MAINTENANCE - CHECK ITEMS

CHECK ITEMS of Air Compressor		FREQUENCY
1	Checking of Draining Tank	Daily
2	Checking of Sound and Vibration performance of Air Compressor	Daily
3	Checking of START and STOP performance of Components	Every 3 Months
4	Cleaning of Intake and Outtake Filters	
5	Checking of Fluid Control Valve	
6	Checking of Electromagnetic Valve	
7	Checking of Hoses	

1. Checking of Draining Tank

Frequency: Daily

If draining tank is not drained, water will enter the air compressor and causing malfunction. Also, the rust inside the air compressor cannot be discharged causing the clog of filters, electromagnetic valve and other components resulting in malfunction.

- (1): Cut off the power of air compressor to discharge the compressed air and water inside the air compressor.
- (2): Pool out the water inside the draining tank as shown in below diagram:

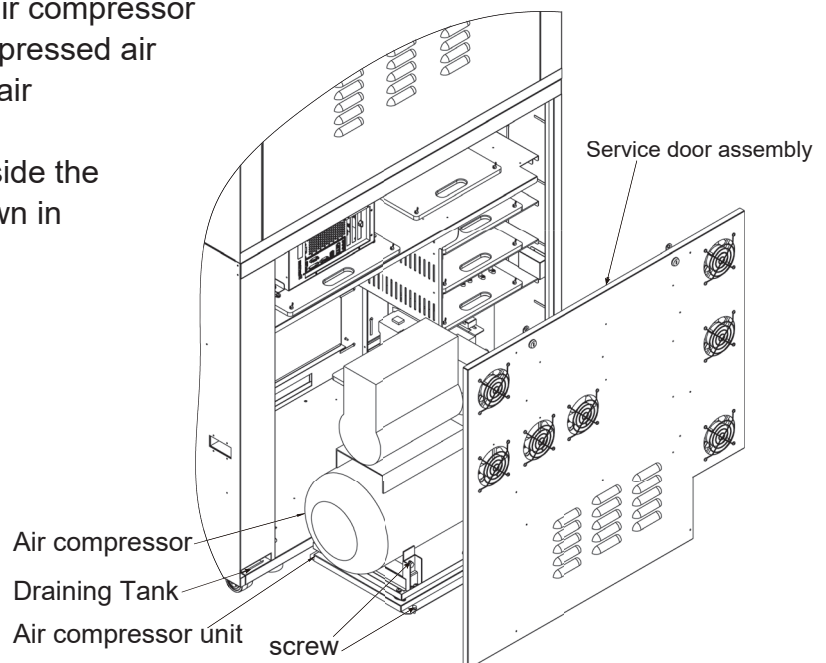

2. Checking of Sound and Vibration performance of Air Compressor

Frequency: Daily

- (1): When the air compressor is operating, please check whether there is any excessive sound and vibration.
- (2): If there is any excessive sound and vibration, please cut off the air compressor power and leave for at least 1 hour for the air compressor to cool down. After that, please check all the air compressor parts, bolts, nuts to see if any is loose.

3. Checking of START and STOP performance of Components

Frequency: Every 3 Months

- (1): Switch on the air compressor to confirm if the air compressor starts normally.
- (2): If the air compressor starts normally, it will stop in normal after 4-5 minutes.
- (3): If the air compressor does not stop in normal after 4-5 minutes, please cut off the power supply of the air compressor unit and the power supply of the main machine. Please check the connection of the air pipes.

4. Cleaning of Intake and Outtake Filters

Frequency: Every 3 Months

If the filter is in dirty condition, clogging will occur and causing the drop of pressure, resulting in malfunction.

- (1): Please remove the air compressor filters. (Please refer to the assembly diagram for details)
- (2): Please remove the dirt around the filters. If the dirt cannot be removed, please replace with a new one.

5. Checking of Fluid Control Valve

Frequency: Every 3 Months

If the fluid control valve is out of work, water cannot be discharged properly, which causing malfunction. Also, the rust inside the air compressor cannot be discharged causing the clog of filters, electromagnetic valve and other components resulting in malfunction.

- (1): Please remove the fluid control valve. (Please refer to the assembly diagram for details)
- (2): Please check to make sure the fluid control valve is in good condition without any damage. Otherwise, please replace with a new one.

6. Checking of Electromagnetic Valve

Frequency: Every 3 Months

- (1): Please remove the electromagnetic valve. (Please refer to the assembly diagram for details)
- (2): Please check to make sure the electromagnetic valve is in good condition without any damage or leakage of air. Otherwise, please replace with a new one.

7. Checking of Hoses

Frequency: Every 3 Months

Please check to make sure all hoses are in good condition without any damage or leakage of air. Otherwise, please replace with a new one.

6. Assembly

6.1 Assembly tree diagram

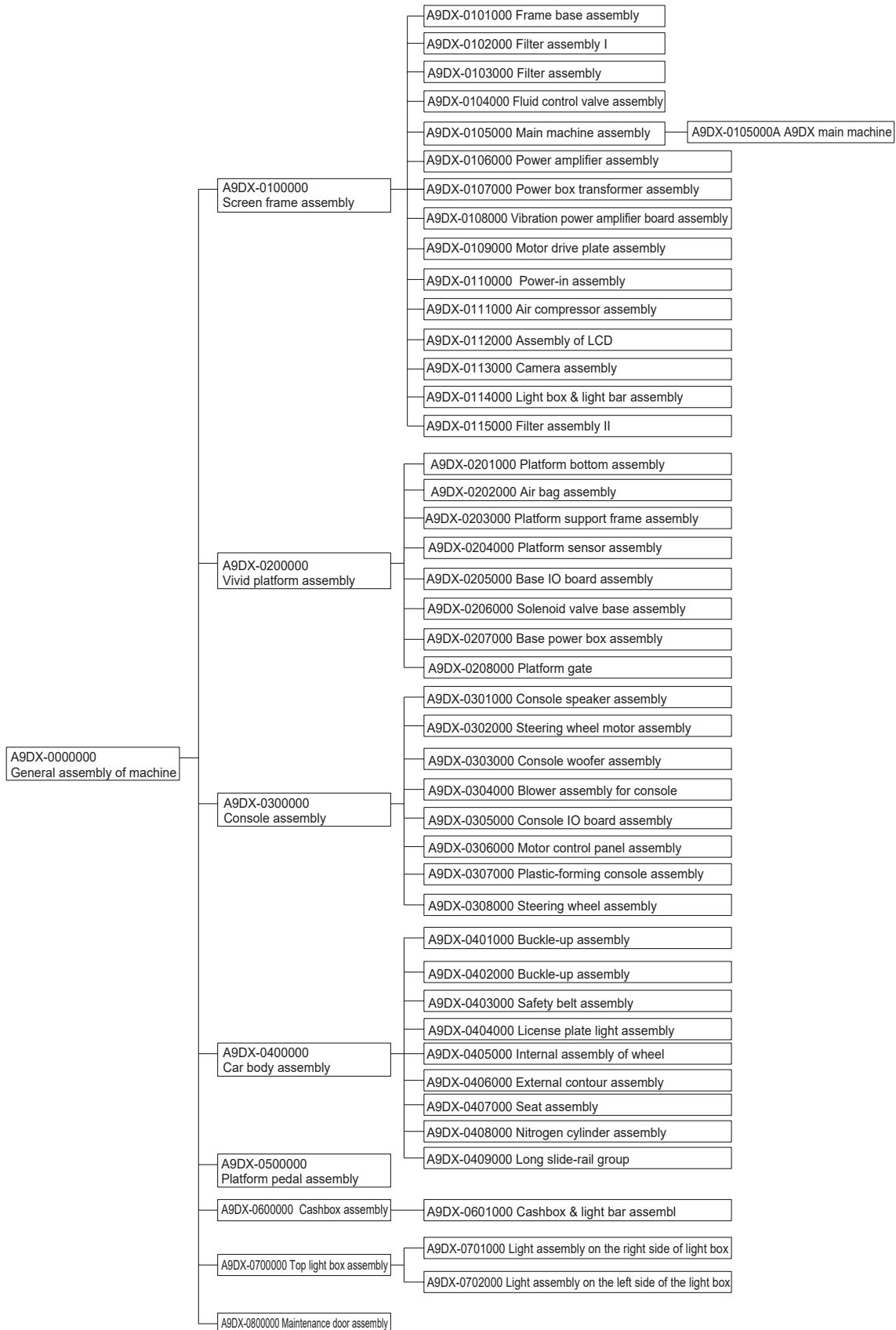

6.2 General assembly of machine(A9DX-0000000)

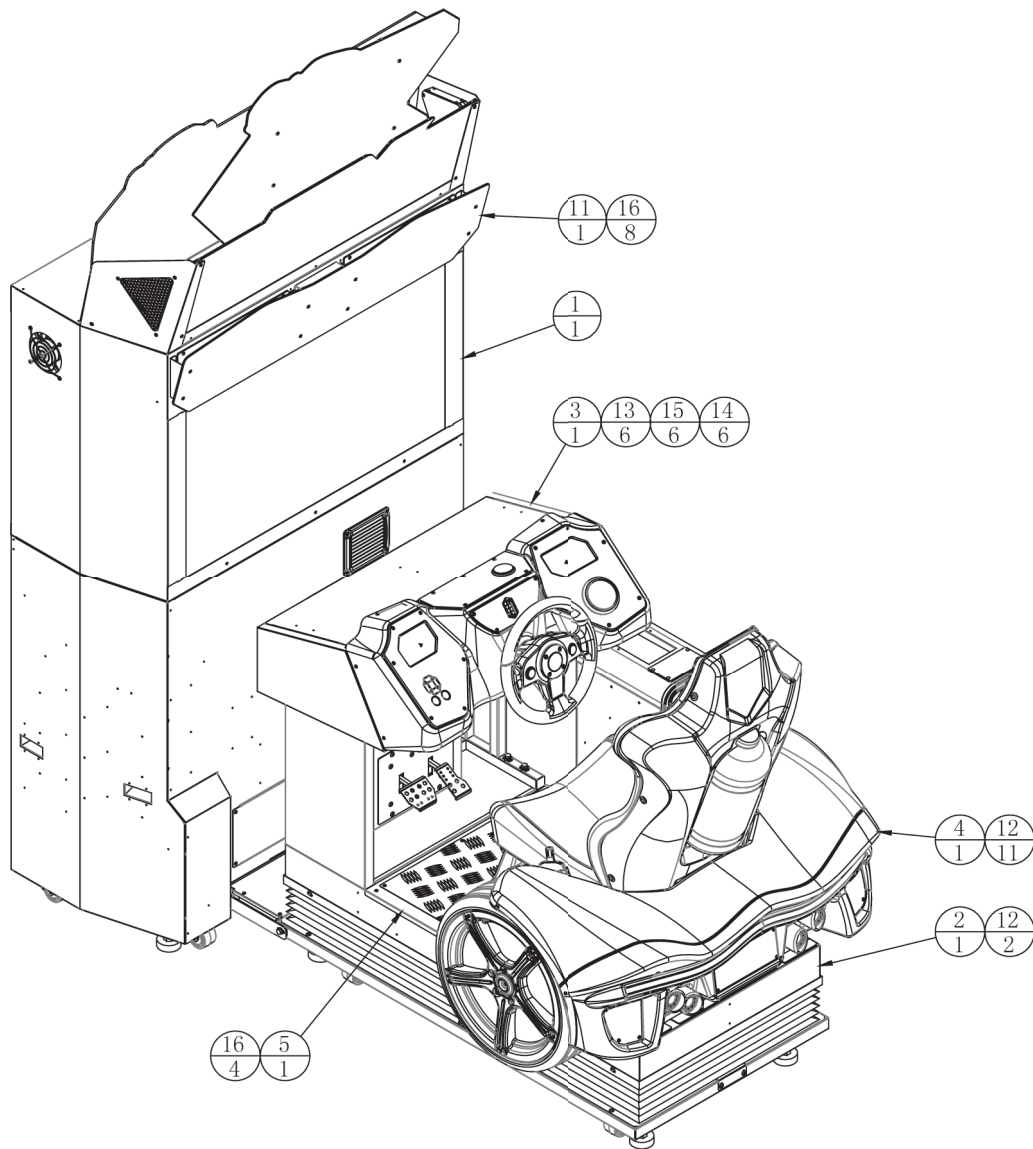

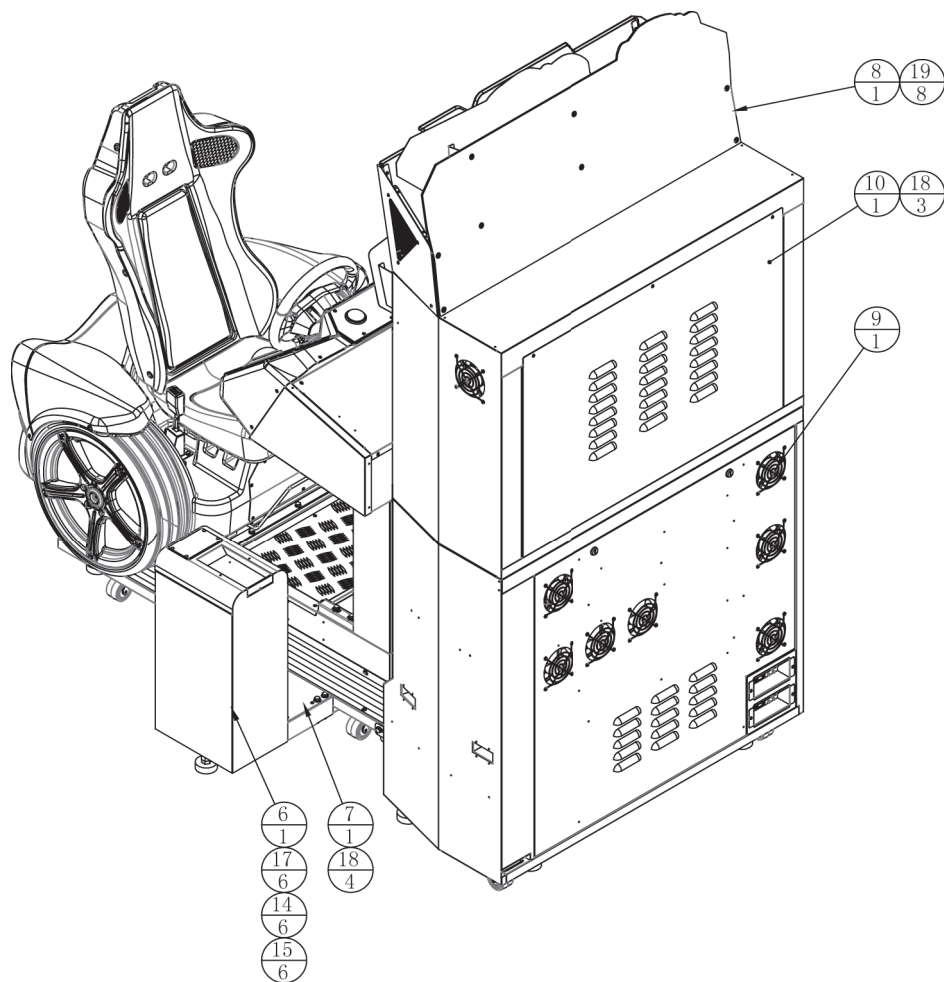

19		Hexagon triple combination	6*16*12*1.2(Black)	8	
18		cross the big flat head screw	M4*8 (Black)	7	
17		external hex socket screw	M8*80 (Black)	6	
16		hex socket cap screws	M4*8 (chrome)	12	
15		plain washers	φ8*φ16*2.0 (Black)	12	
14		spring washer	M8 (Black)	12	
13		external hex socket screw	M8*50 (Black)	6	
12		Hexagon triple combination	8*20*16*1.5(Black)	11	
11	A9DX-P0004	Camera decorative plate	PMMA-3.0T	1	1.7.IG39A00150
10	A9DX-0000A02	Top maintenance door	SPCC-1.5T	1	1.1.IG39A00020
9	A9DX-0800000	Top light box assembly		1	
8	A9DX-0700000	Upper cover of cash box connection		1	
7	A9DX-0000A01	Cash box assembly	SPCC-1.2T	1	1.1.IG39A00010
6	A9DX-0600000	Cashbox assembly		1	
5	A9DX-0500000	Platform pedal assembly		1	
4	A9DX-0400000	Car body assembly		1	
3	A9DX-0300000	Console assembly		1	
2	A9DX-0200000	Vivid platform assembly		1	
1	A9DX-0100000	Screen frame assembly		1	
No.	Draw No.	Name	Material/Spec.	Qty.	Product Code

6.3 Screen frame assembly (A9DX-0100000)

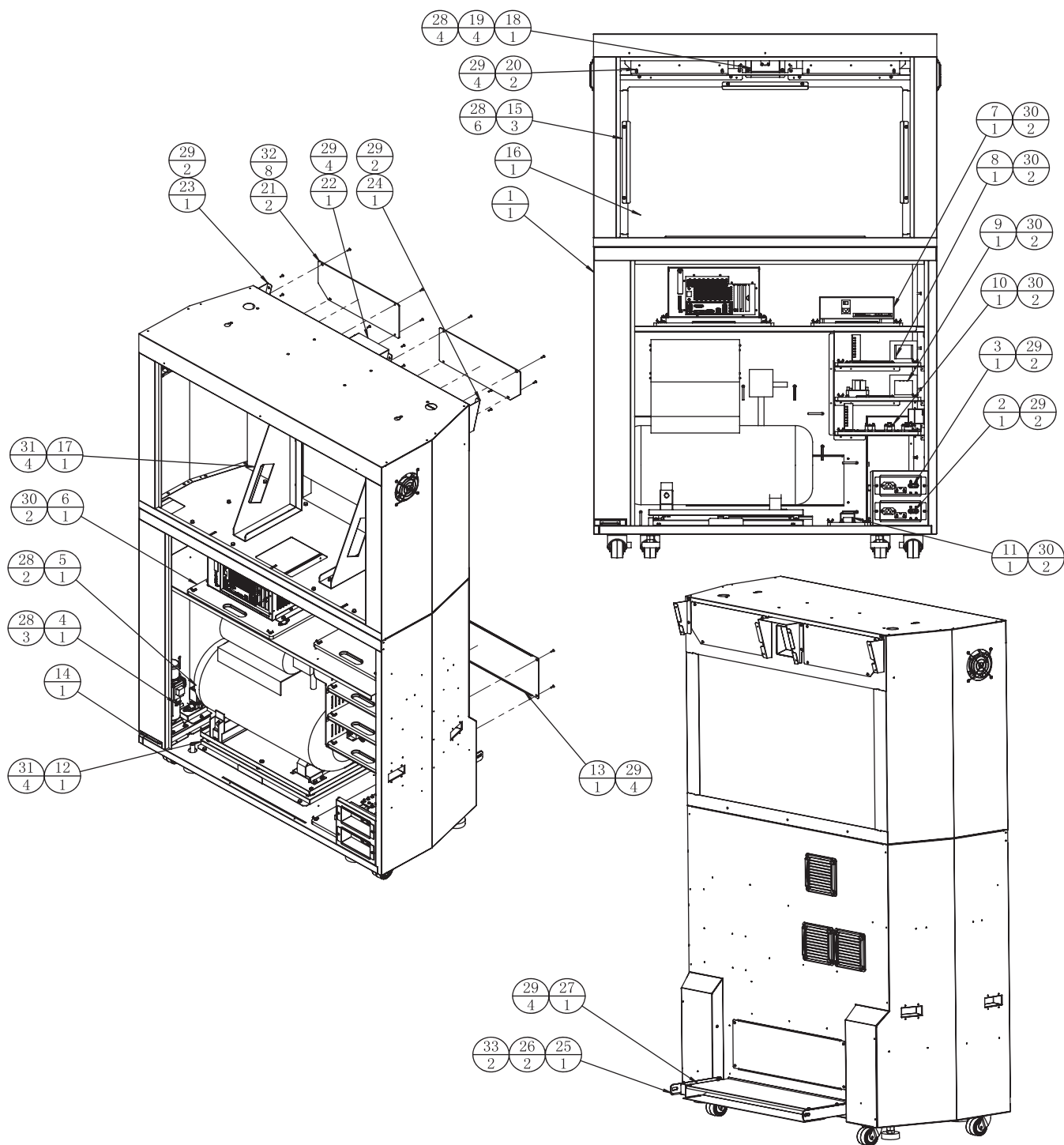

33		Hexagon triple combination	8*30*16*1.5(Black)	2	
32		cross the big flat head screw	M4*12 (chrome)	8	
31		Hexagon triple combination	6*16*12*1.2(Black)	8	
30		butterfly screws	M4*20 (chrome)	12	
29		cross the big flat head screw	M4*12 (Black)	24	
28		hex head cap screw	M4 (Colour)	15	
27	A9DX-0100A08	Connecting cover plate	SPCC-1.5T	1	1.1.IG39A00110
26	HVR-0000C02	Separation column	Black POM	2	1.8.IG32A070
25	A9DX-0100A07	Connecting fixing plate		1	1.1.IG39A00100
24	A9DX-0100A06	Screen acrylic fixing plate 3	SPCC-1.2T	1	1.1.IG39A00090
23	A9DX-0100A05	A fixed screen acryl plate	SPCC-1.2T	1	1.1.IG39A00080
22	A9DX-0100A04	The acryl screen a fixed plate	SPCC-1.2T	1	1.1.IG39A00070
21	A9DX-0100D01	Screen light box cover plate	PMMA-3.0T	2	1.7.IG39A00010
20	A9DX-0114000	Light box & light bar assembly		2	
19		Transistor gasket	TW-102	4	1.4.DC102220
18	A9DX-0113000	Camera assembly		1	
17	A9DX-0112000	Assembly of LCD		1	
16	WAH-0000C05	42" led screen glass a	glass-5.0T	1	1.8.AA030050
15	A9DX-0100A03	Screen glass fixing plate	SECC-1.0T	3	1.1.IG39A00060
14	A9DX-0100A02	Water collecting tray		1	1.1.IG39A00050
13	A9DX-0100A01	Main frame front maintenance door	SPCC-1.5T	1	1.1.IG39A00040
12	A9DX-0111000	Air compressor assembly		1	
11	A9DX-0110000	Power-in assembly		1	
10	A9DX-0109000	Motor drive plate assembly		1	
9	A9DX-0108000	Vibration power amplifier board assembly		1	
8	A9DX-0107000	Power amplifier assembly		1	
7	A9DX-0106000	Power amplifier assembly		1	
6	A9DX-0105000	Main machine assembly		1	
5	A9DX-0104000	Fluid control valve assembly		1	
4	A9DX-0103000	Filter assembly		1	
3	A9DX-0115000	Filter assembly II		1	
2	A9DX-0102000	Filter assembly I		1	
1	A9DX-0101000	Frame base assembly		1	
No.	Draw No.	Name	Material/Spec.	Qty.	Product Code

6.3.1 Frame base assembly (A9DX-0101000)

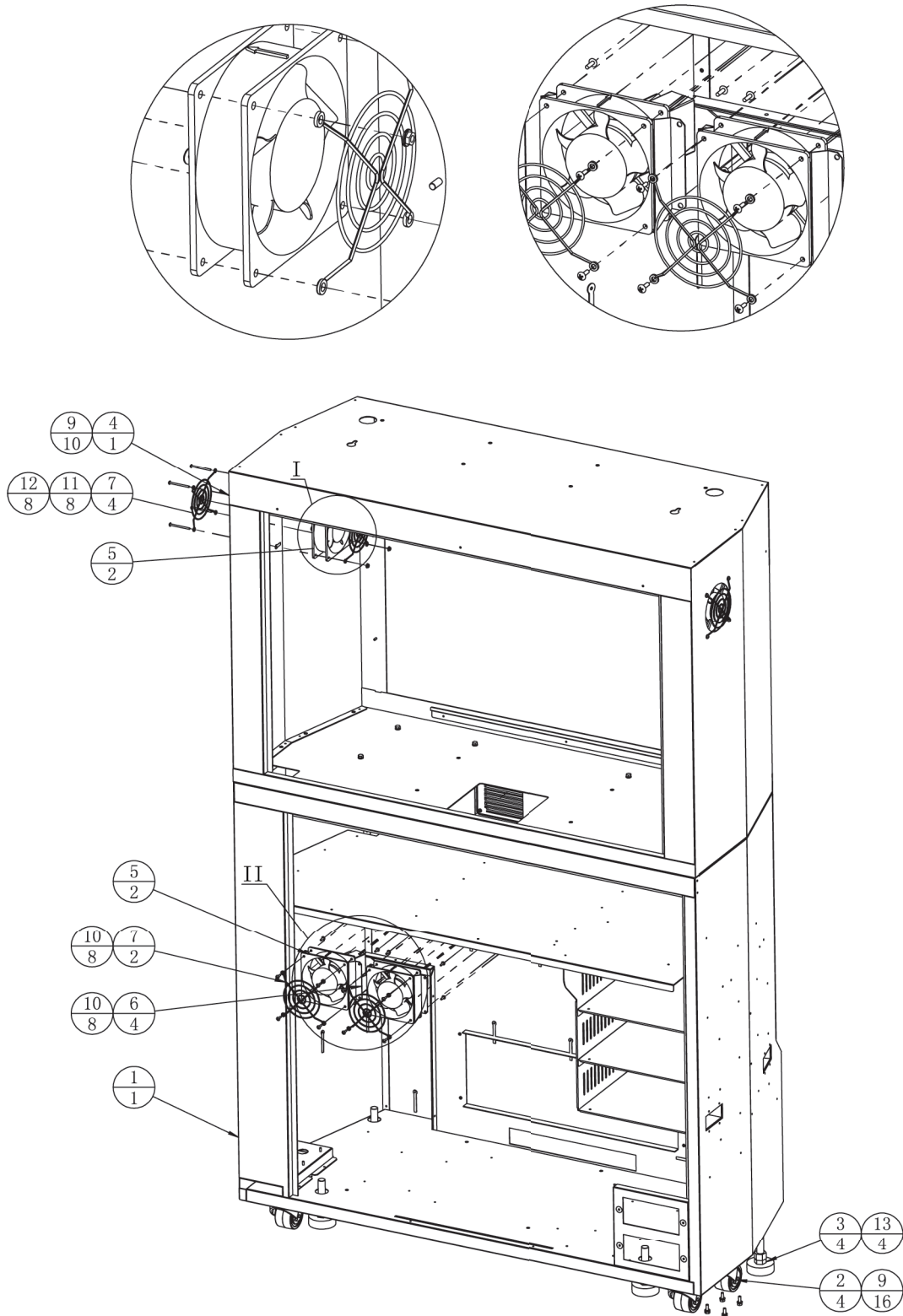

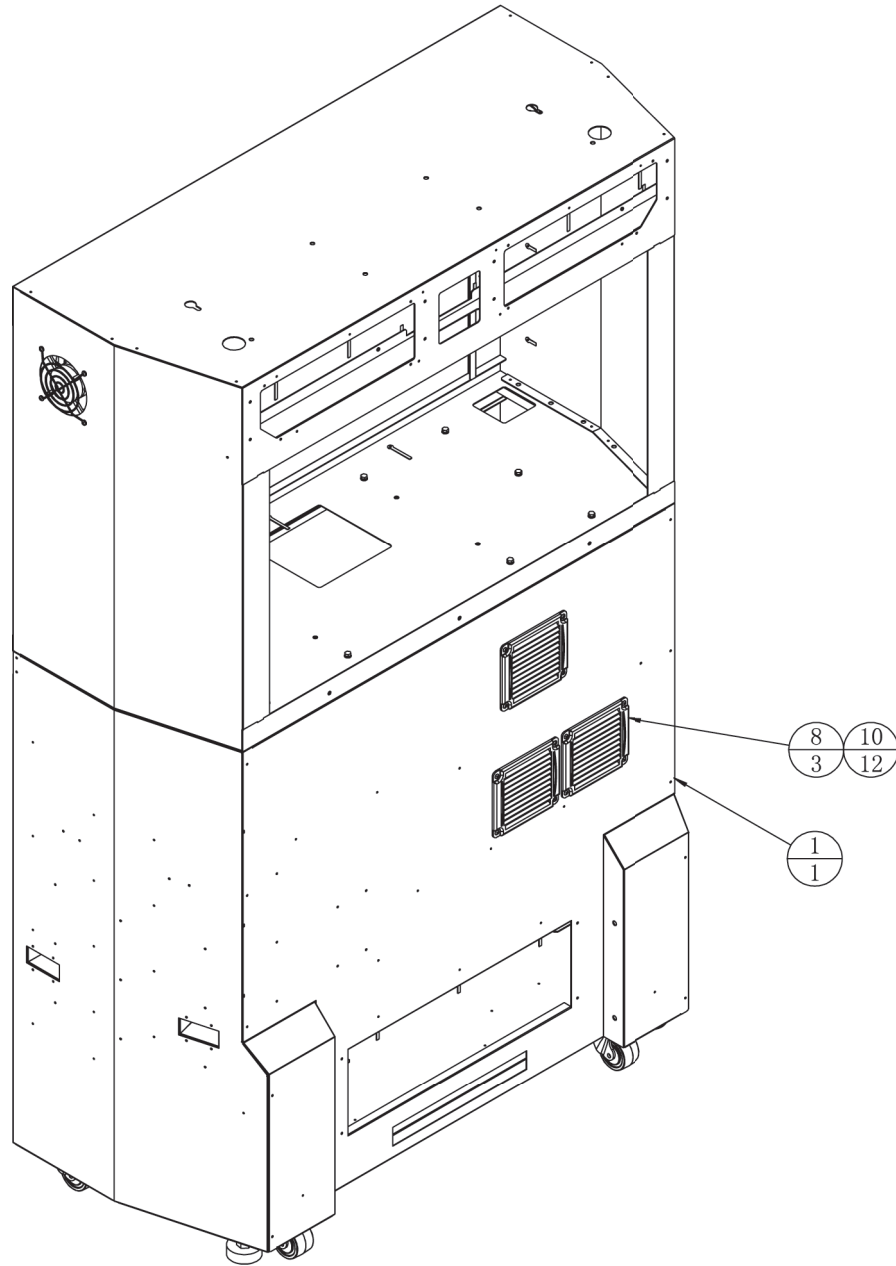

13		hexagon nut	M16 (Colour)	4	
12		hex head cap screw	M4 (Colour)	8	
11		cross the big flat head screw	M4*50 (stainless steel)	8	
10		cross the big flat head screw	M4*12 (Black)	28	
9		Hexagon triple combination	6*16*12*1.2(Black)	26	
8		plastic air network	253-5460	3	1.4.FS500010
7		fan cover	120*120	6	1.4.FS300020
6	vbp-01-14-01	fan bracket	SECC-1.0T	4	1.1.IG13A00280
5		fan with bearing	120*120/AC110V	4	1.4.FS200042
4	A9DX-0101A02	Upper seat of main frame		1	1.1.IG39A00130
3		anchor bolt (rubber bottom)	M16*100(Colour)	4	
2		casters	2.5 inch low center of gravity type	4	1.4.JL302520
1	A9DX-0101A01	Main frame base		1	1.1.IG39A00120
No.	Draw No.	Name	Material/Spec.	Qty.	Product Code

6.3.2 Filter assembly I(A9DX-0102000)

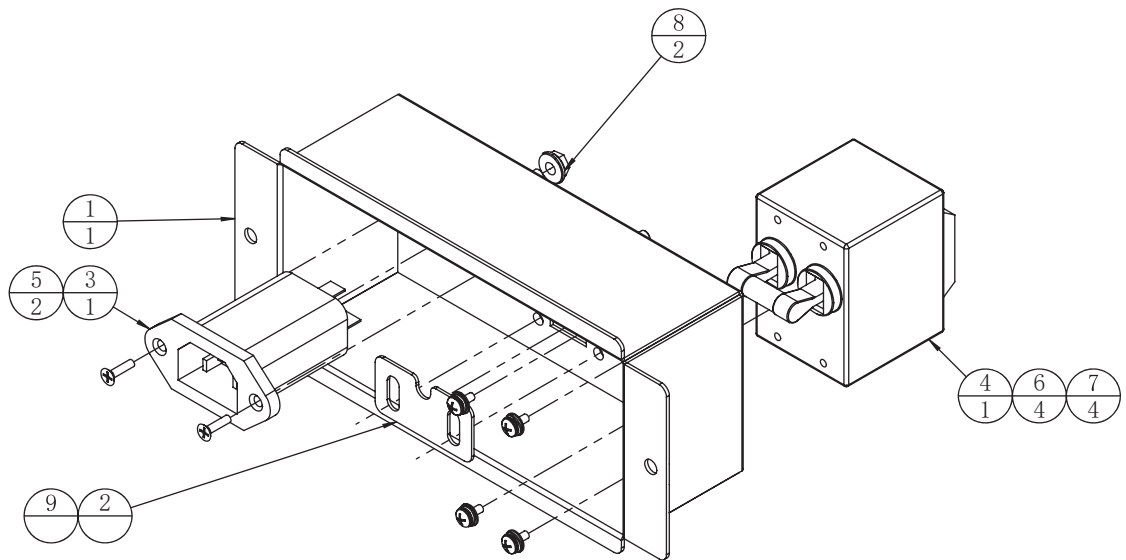

9		cross the big flat head screw	M4*8 (Black)	2	
8		hex head cap screw	M4 (Colour)	2	
7		cross recessed fillister head three-combination screw	M4*8 (chrome)	4	
6		cross recessed fillister head three-combination screw	M3*6 (chrome)	4	
5		cross recessed countersunk head screws	M3*10 (Black)	2	
4		leakage protection switch (double row)	HD30-2PAC 250V/20A	1	1.4.SW804012
3		filter	YB11A2-15A-Q	1	1.4.LB100080
2	A9DX-0102A02	Net wire fixing plate	SPCC-1.0T	1	1.1.IG39A00150
1	A9DX-0102A01	Filter fixing plate	SPCC-1.2T	1	1.1.IG39A00140
No.	Draw No.	Name	Material/Spec.	Qty.	Product Code

6.3.3 Filter assembly(A9DX-0103000)

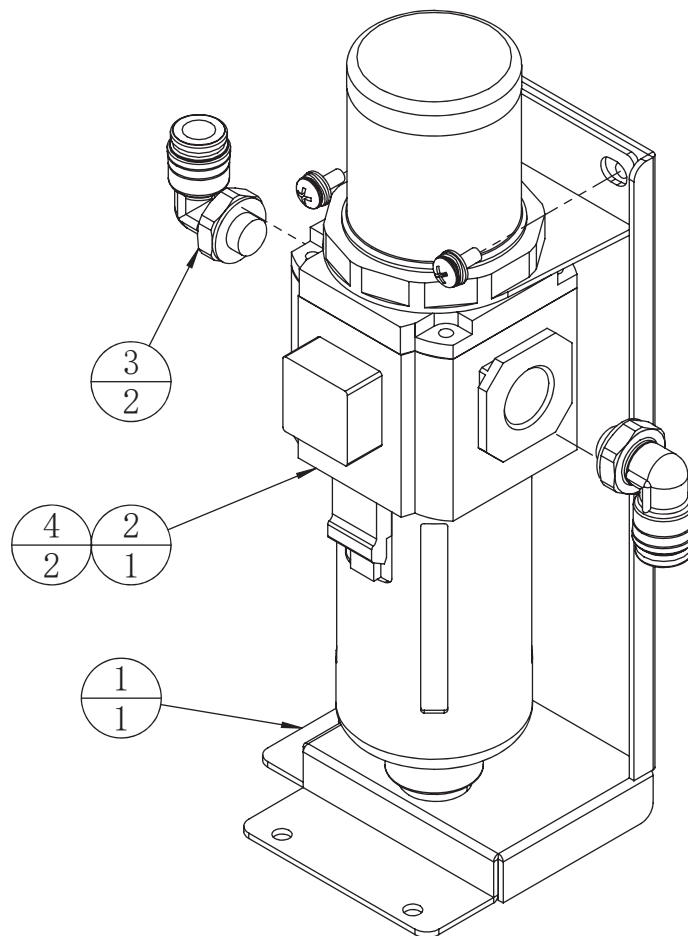

4		cross recessed fillister head three-combination screw	M5*12 (Black)	2	
3		I type screw thread connector	APL10-04	2	1.4.JG072100
2		surge filters	GFR40015AF1	1	1.4.LB200030
1	A9DX-0103A01	Regulator fixed iron	SPCC-2.0T	1	1.1.IG39A00160
No.	Draw No.	Name	Material/Spec.	Qty.	Product Code

6.3.4 Fluid control valve assembly(A9DX-0104000)

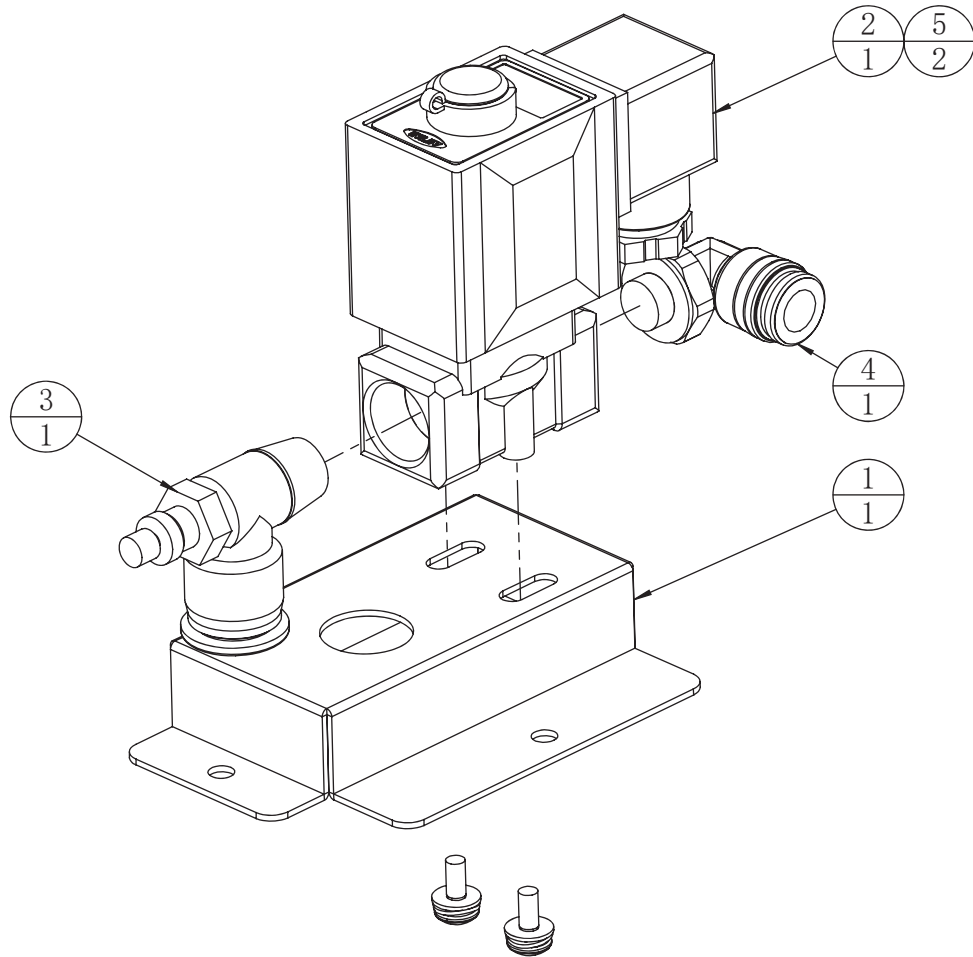

5		cross recessed fillister head three-combination screw	M5*12 (Black)	2	
4		I type screw thread connector	APL10-04	1	1.4.JG072100
3		one-way throttle valve - pipe connector	ASL10-04B	1	1.4.JG09A020
2		fluids control valve	2L050-15-F	1	1.4.JG09A041
1	A9DX-0104A01	Fixed iron of fluid control valve	SPCC-1.5T	1	1.1.IG39A00170
No.	Draw No.	Name	Material/Spec.	Qty.	Product Code

6.3.5 Main machine assembly(A9DX-0105000)

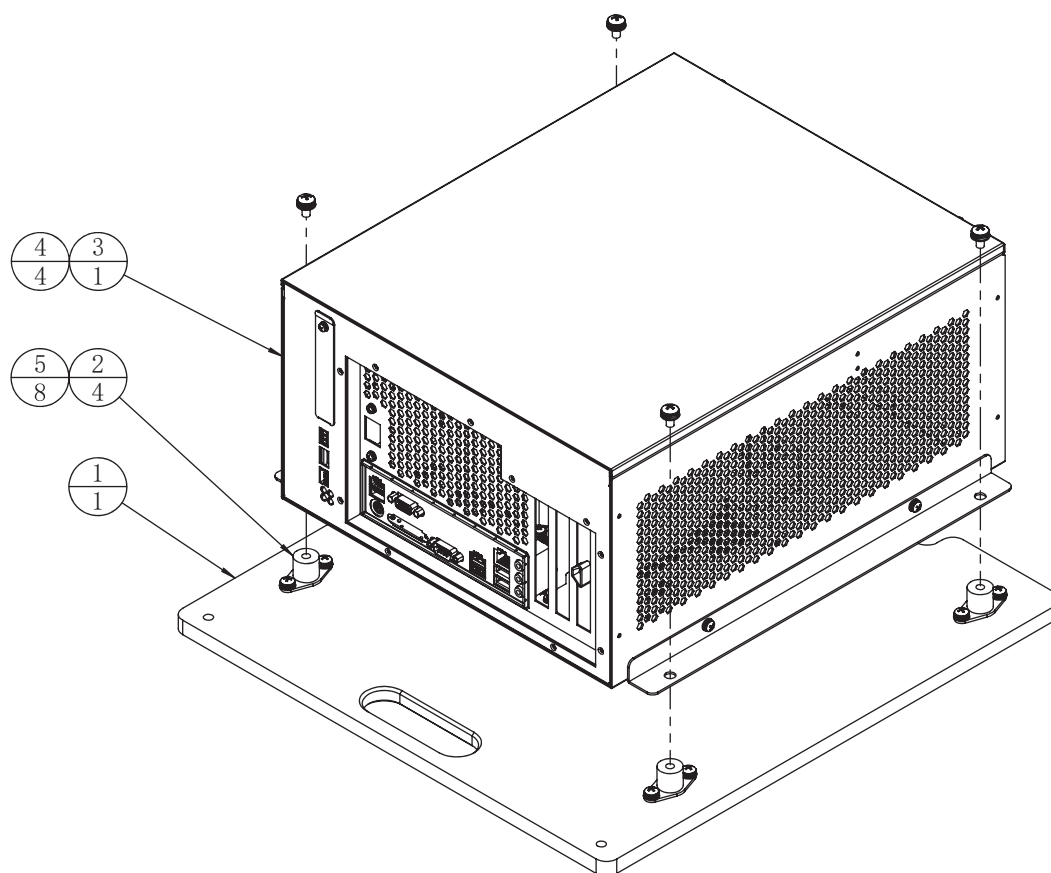

5		cross recessed fillister head three-combination screw	M5*12 (Black)	8	
4		cross recessed fillister head three-combination screw	M6*12 (Black)	4	
3	A9DX-0105000A	A9DX main machine		1	
2		lanhe shaped foot shock		4	1.8.AA000250
1	A9DX-0105B01	Host fixed wood	MDF-12.0T	1	1.2.IG39A00010
No.	Draw No.	Name	Material/Spec.	Qty.	Product Code

6.3.5.1 A9DX main machine(A9DX-0105000A)

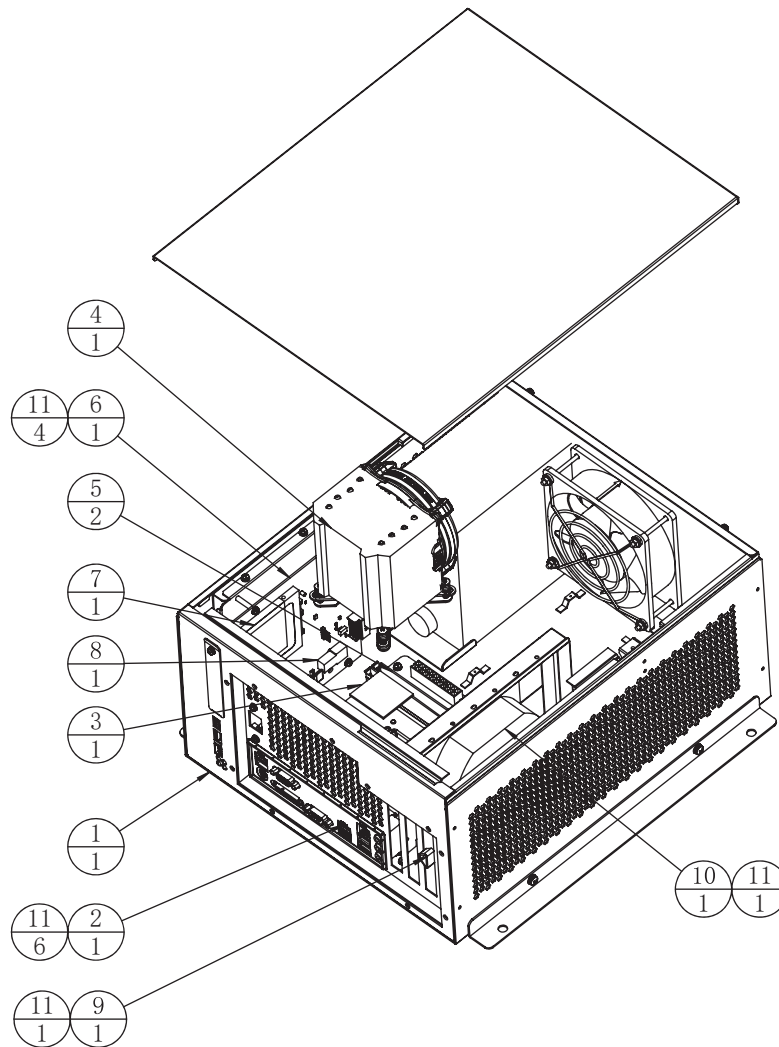

11		cross recessed fillister head three-combination screw	M3*8 (chrome)	12	
10	0991-50000257	graphics card	GTX 1650 OC 4GREV1.0(RoHS)	1	1.3.IG39A00070
9	1134-50005000	Expansion baffle	12CF1-1CM001-31R, RS2329PIN Single Port+ baffle (including wire)	1	1.3.IG39A00170
8	0991-50000143	dongle	SENTINEL HARDWAREKEY_KEY(ROHS)	1	1.3.IG39A00120
7	0995-50000016	hard disc	SSD_64GB(MLC)(RoHS)	1	1.3.IG39A00080
6	5651-00000206	M23 protection plate	NZ-#-0(RoHS)	1	1.3.IG39A00130
5	0583-00000035	memory card	SDRAM MODULE 8G DDR 2400(RoHS)	2	1.3.IG39A00110
4	0991-50000220	Fan assembly	TAISOL, heat sink (94*121*4.5.4mm)+ fan (3800RPM+/-10%)+ component	1	1.3.IG39A00100
3	0552-20000029	CPU	Intel,3M Cache,3.9GHz,FCLGA14C	1	1.3.IG39A00090
2	0991-50000244	mother board	Gigabyte,BIOS(compatible version F21F ZG), with enhanced ESD foam stop (12AIO-D4A385-14R)	1	1.3.IG39A00060
1	VS-0000000	V3000 host housing		1	
No.	Draw No.	Name	Material/Spec.	Qty.	Product Code

6.3.6 Power amplifier assembly(A9DX-0106000)

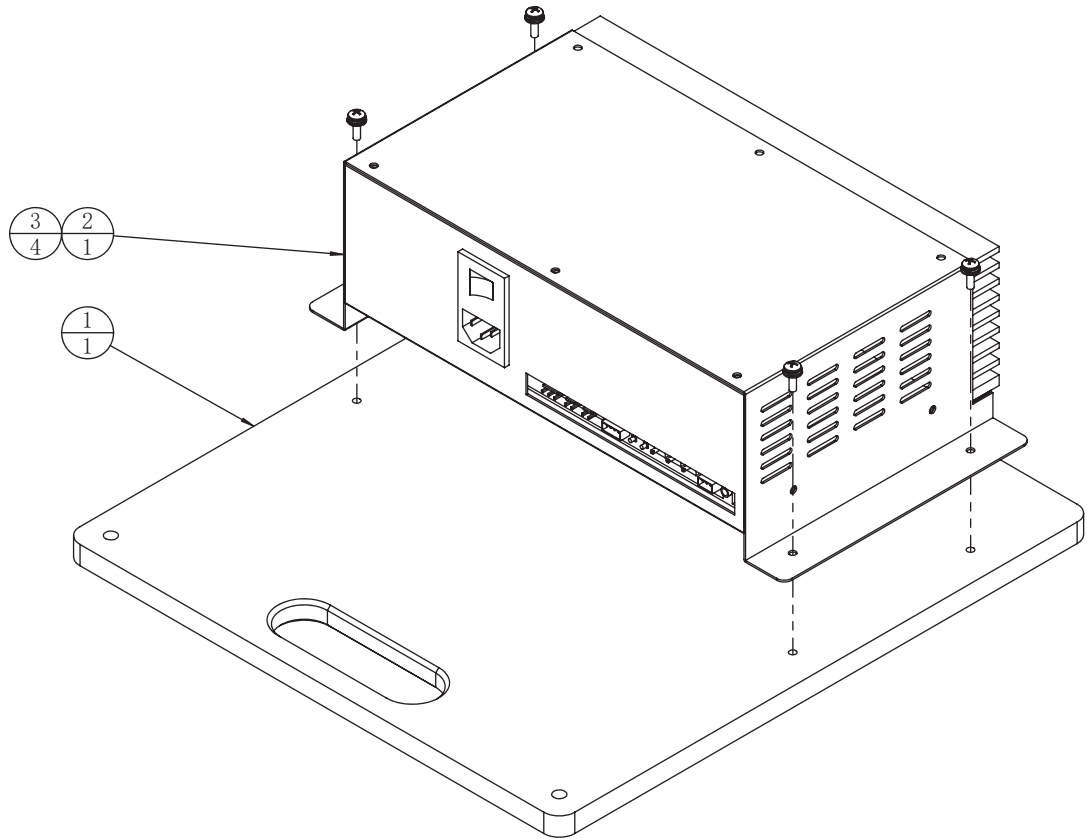

3		cross recessed fillister head three-combination screw	M4*12 (chrome)	4	
2		4.1 amplifier	JK-OP-03	1	1.4.GF100022
1	A9DX-0106B01	amplifier panel	MDF-12.0T	1	1.2.IG39A00020
No.	Draw No.	Name	Material/Spec.	Qty.	Product Code

6.3.7 Power box transformer assembly(A9DX-0107000)

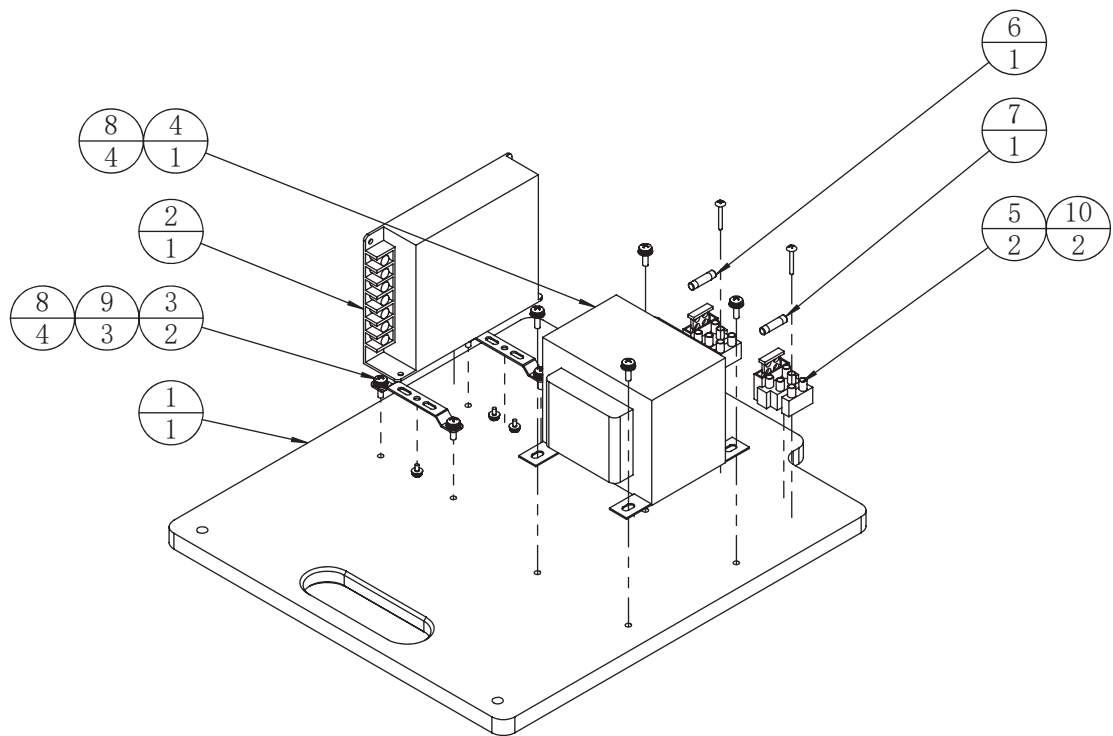

10		cross the big flat head self-drilling screw	M3*20 (chrome)	2	
9		cross recessed fillister head three-combination screw	M3*8 (chrome)	3	
8		cross recessed fillister head three-combination screw	M4*12 (chrome)	8	1.4.BX001-00340
7		Fuse tube	F5A/5*20 250V UL	1	1.4.BX001-00330
6		Fuse tube	F3.15A/5*20 250V UL	1	1.4.BX001-00300
5		fusehold	FT06-3	2	
4		transformer	220V/110V 70V-10V/3A	1	1.4.BY103030
3	AST-0101A10	Long fixing plate at the bottom of power box	SECC-1.2T	2	1.1.AN17A00310
2		power supply	LRS-100-12	1	1.4.DY170120
1	A9DX-0107B01	fixed power supply board	MDF-12.0T	1	1.2.IG39A00030
No.	Draw No.	Name	Material/Spec.	Qty.	Product Code

6.3.8 Vibration power amplifier board assembly(A9DX-0108000)

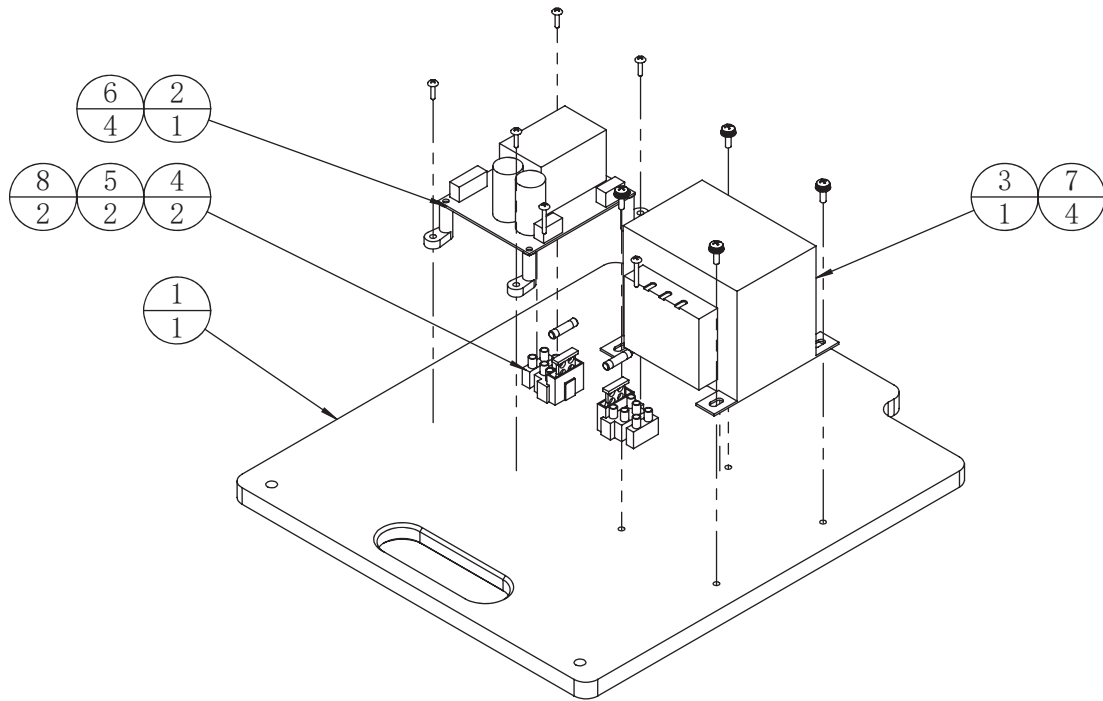

8		cross the big flat head self-drilling screw	M3*20 (chrome)	2	
7		cross recessed fillister head three-combination screw	M4*12 (chrome)	4	
6		cross the big flat head self-drilling screw	M3*12 (chrome)	4	
5		Fuse tube	F8A/5*20 250V/UL	2	1.4.BX001-00400
4		fusehold	FT06-3	2	1.4.BX001-00300
3		transformer	200W AC220/110V 16V-0V-16V	1	1.4.BY202050
2		Digital version of vibration power amplifier	JK-OP-08	1	1.4.IC901801
1	A9DX-0108B01	Vibration power amplifier board	MDF-12.0T	1	1.2.IG39A00040
No.	Draw No.	Name	Material/Spec.	Qty.	Product Code

6.3.9 Motor drive plate assembly (A9DX-0109000)

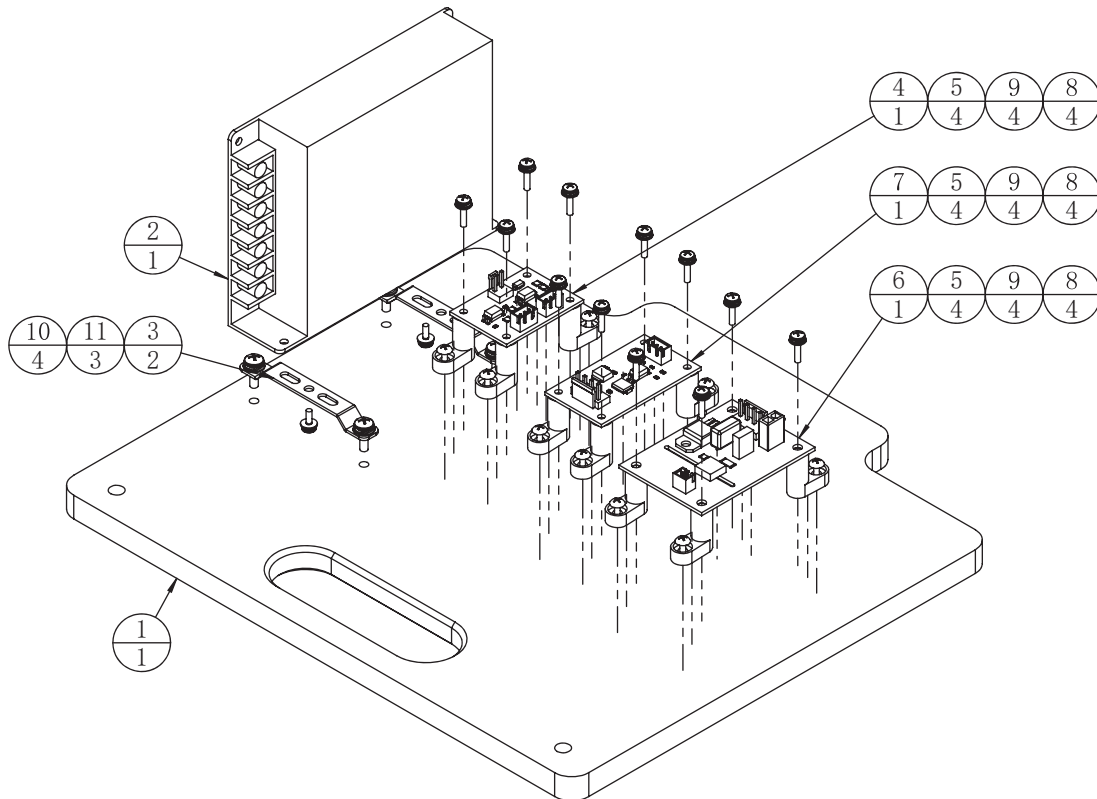

11		cross recessed fillister head three-combination screw	M3*8 (chrome)	3	
10		cross recessed fillister head three-combination screw	M4*12 (chrome)	4	
9		cross recessed fillister head three-combination screw	M3*12 (chrome)	12	
8		cross the big flat head self-drilling screw	M3*12 (chrome)	12	
7		Isolated NMOS driving board	OC-1279-00	1	1.4.IC903190
6		Ac motor drive board	MF-E-1140-01	1	1.4.IC903210
5		I-holder	M3mm	12	1.9.LX103010
4		Air compressor power supply detection board	NI-A-1275-00	1	1.4.IC903200
3	AST-0101A10	Long fixing plate at the bottom of power box	SECC-1.2T	2	1.1.AN17A00310
2		power supply	LRS-100-12	1	1.4.DY170120
1	A9DX-0109B01	Drive motor fixing plate	MDF-12.0T	1	1.2.IG39A00050
No.	Draw No.	Name	Material/Spec.	Qty.	Product Code

6.3.10 Power-in assembly (A9DX-0110000)

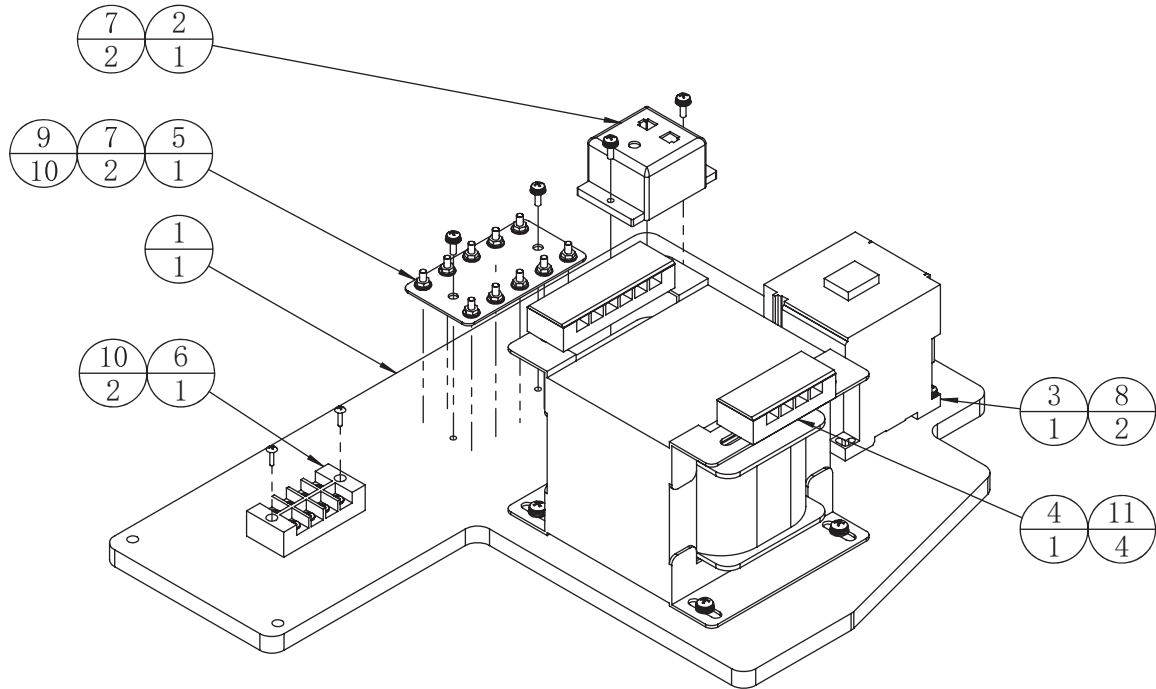

11		cross recessed fillister head three-combination screw	M5*12 (chrome)	4	
10		cross the big flat head self-drilling screw	M3*12 (chrome)	2	
9		hex head cap screw	M4 (Colour)	10	
8		cross recessed fillister head three-combination screw	M4*20 (chrome)	2	
7		cross recessed fillister head three-combination screw	M4*12 (chrome)	4	
6		Terminal	TB2504	1	1.5.XC401030
5	WAH-0000A13	Ground cable plate	SECC-1.5T	1	1.1.AA09000130
4		Single-phase control transformer	EI-133*100(H50 0.5MM)	1	1.4.BY305040
3		Ac contactor	S-P30TH 220V	1	1.4.ZD200010
2		Exposed a multi-purpose socket	20A/250V	1	1.4.IC220020
1	A9DX-0110B01	Power-in fixed template	MDF-12.0T	1	1.2.IG39A00060
No.	Draw No.	Name	Material/Spec.	Qty.	Product Code

6.3.11 Air compressor assembly(A9DX-0111000)

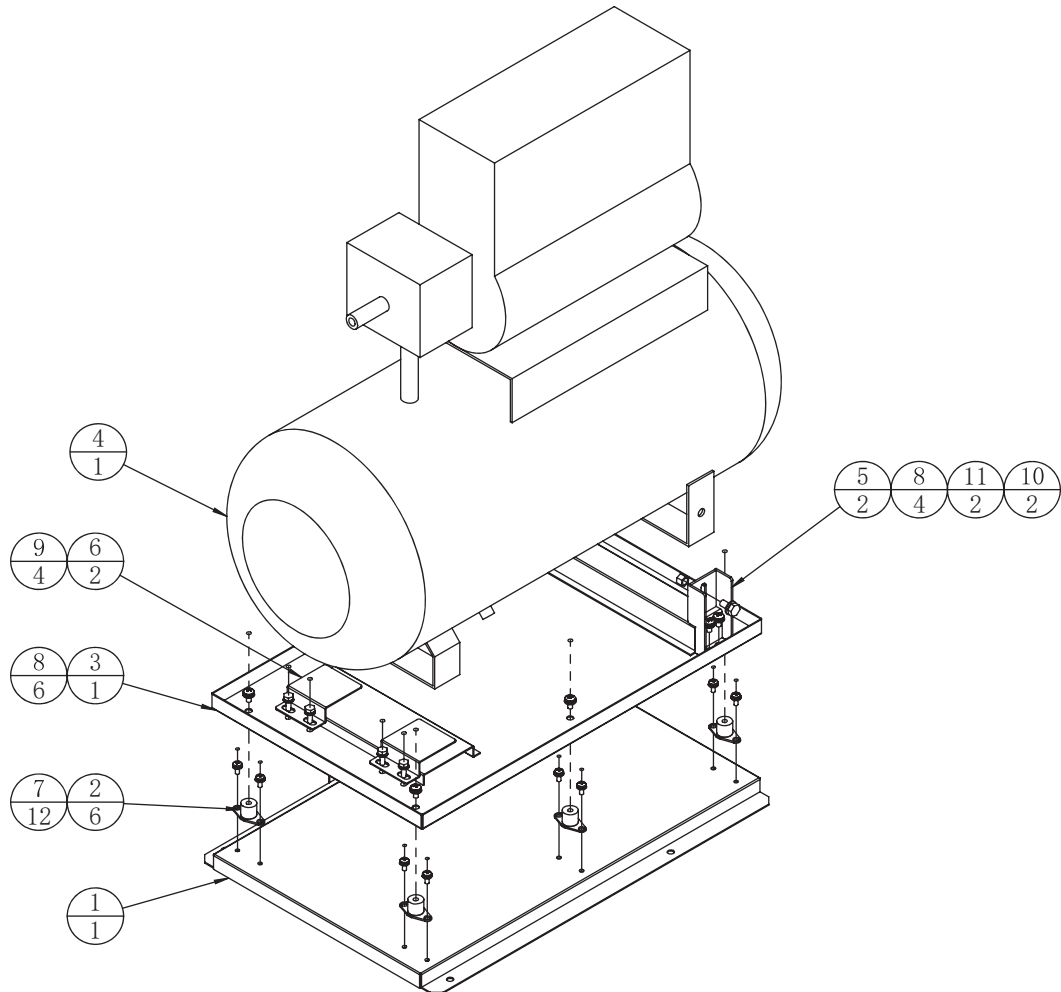

11		Hexagon triple combination	8*16*16*1.5(Black)	2	
10		Self-Locking Nuts	M8 (Galvanization)	2	
9		Hexagon triple combination	6*16*12*1.2(Black)	4	
8		cross recessed fillister head three-combination screw	M6*12 (Black)	10	
7		cross recessed fillister head three-combination screw	M5*12 (Black)	12	
6	HXD-0103A03	air compressor pressure iron	SPCC-1.5T	2	1.1.IG19G00160
5	SRH-0108A02	air compressor fixed iron	SPCC-2.5T	2	1.1.WA16C00230
4		air compressor	S10(AC220V)	1	1.4.KY100030
3	HXD-0103A02	air compressor support set		1	1.1.IG19G00150
2		lanhe shaped foot shock		6	1.8.AA000250
1	HXD-0103A01	air compressor shockproof seat		1	1.1.IG19G00140
No.	Draw No.	Name	Material/Spec.	Qty.	Product Code

6.3.12 Assembly of LCD(A9DX-0112000)

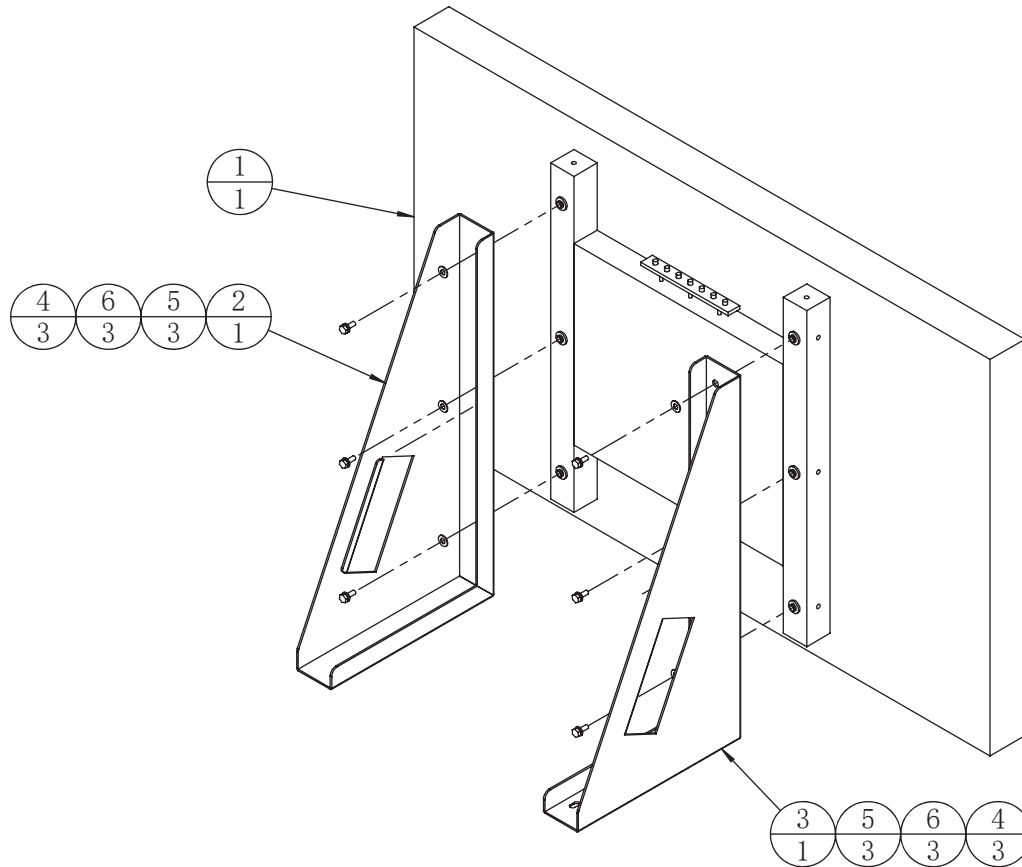

6		Nylon Wah	WS7-1	6	1.4.DC102210
5		Transistor gasket	TW-109	6	1.4.DC102220
4		Hexagon triple combination	6*16*12*1.2(Black)	6	
3	A9DX-0112A02	Screen fixing frame -R	SPCC-2.5T	1	1.1.IG39A00190
2	A9DX-0112A01	Screen fixing frame -L	SPCC-2.5T	1	1.1.IG39A00180
1		Liquid crystal display	43 "	1	1.4.XS405820
No.	Draw No.	Name	Material/Spec.	Qty.	Product Code

6.3.13 Camera assembly(A9DX-0113000)

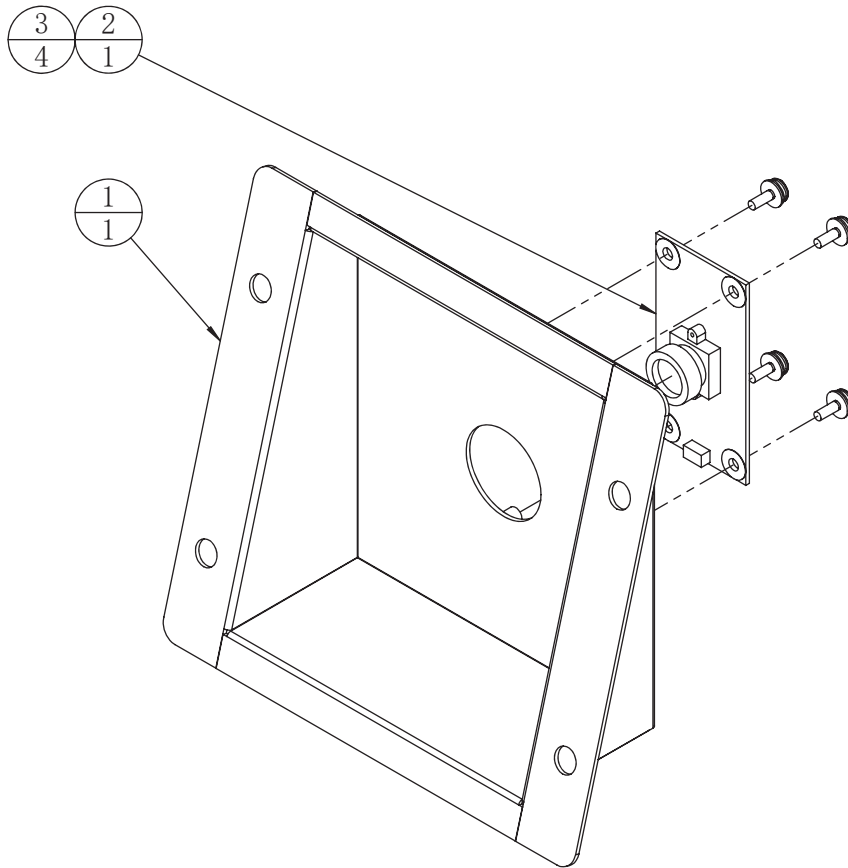

3		cross recessed fillister head three-combination screw	M3*8 (chrome)	4	
2	0991-50000223	camera	USB2.0 High Speed, Male End Cable Length 250cm, 2.0m PC Camer, Resolution :1920*1080,FW:Rev_0200	1	1.3.IG39A00050
1	A9DX-0113A01	Camera bracket	SPCC-1.2T	1	1.1.IG39A00200
No.	Draw No.	Name	Material/Spec.	Qty.	Product Code

6.3.14 Light box & light bar assembly(A9DX-0114000)

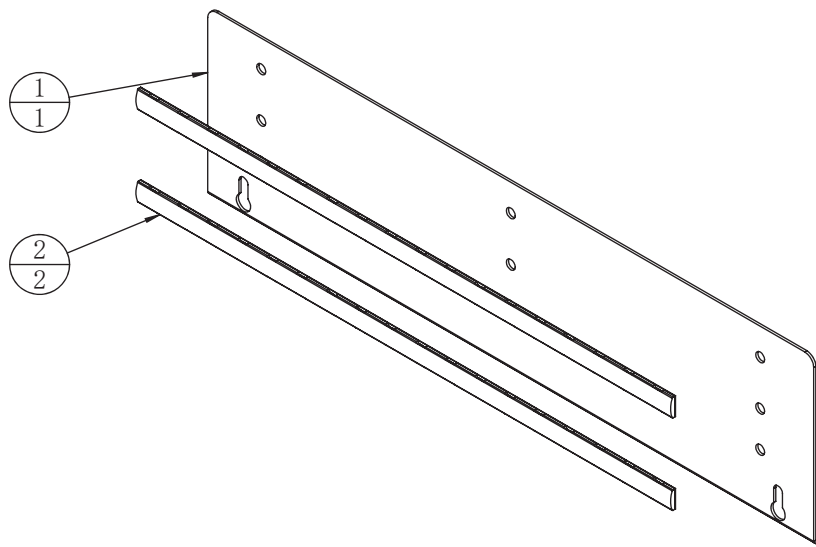

2		5050 strip light	DC12V 60 Light L=300mm	2	1.4.ZM9E0026
1	A9DX-0114A01	Light box article lamp bracker	SECC-1.2T	1	1.1.IG39A00210
No.	Draw No.	Name	Material/Spec.	Qty.	Product Code

6.3.15 Filter assembly II(A9DX-0115000)

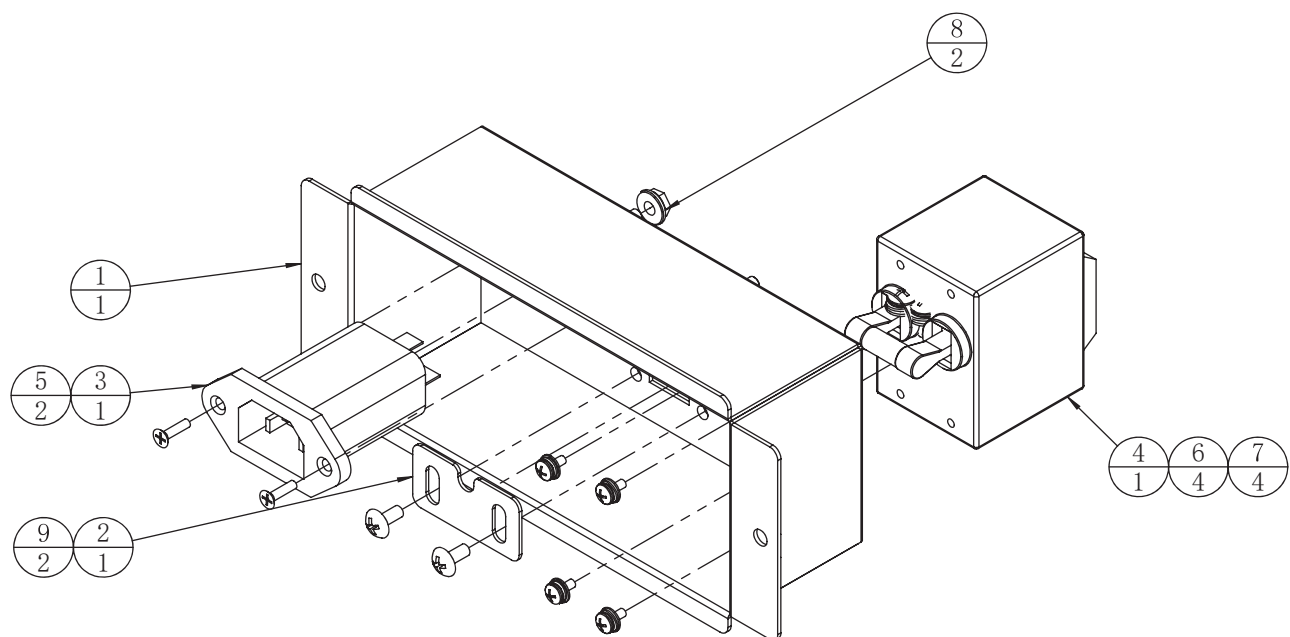

9		cross the big flat head screw	M4*8 (Black)	2	
8		hex head cap screw	M4 (Colour)	2	
7		cross recessed fillister head three-combination screw	M4*8 (chrome)	4	
6		cross recessed fillister head three-combination screw	M3*6 (chrome)	4	
5		cross recessed countersunk head screws	M3*10 (Black)	2	
4		leakage protection switch (double row)	HD30-2PAC 250V/15A	1	1.4.SW804011
3		filter	YB11A2-15A-Q	1	1.4.LB100080
2	A9DX-0102A02	Net wire fixing plate	SPCC-1.0T	1	1.1.IG39A00150
1	A9DX-0102A01	Filter fixing plate	SPCC-1.2T	1	1.1.IG39A00140
No.	Draw No.	Name	Material/Spec.	Qty.	Product Code

6.4 Vivid platform assembly (A9DX-0200000)

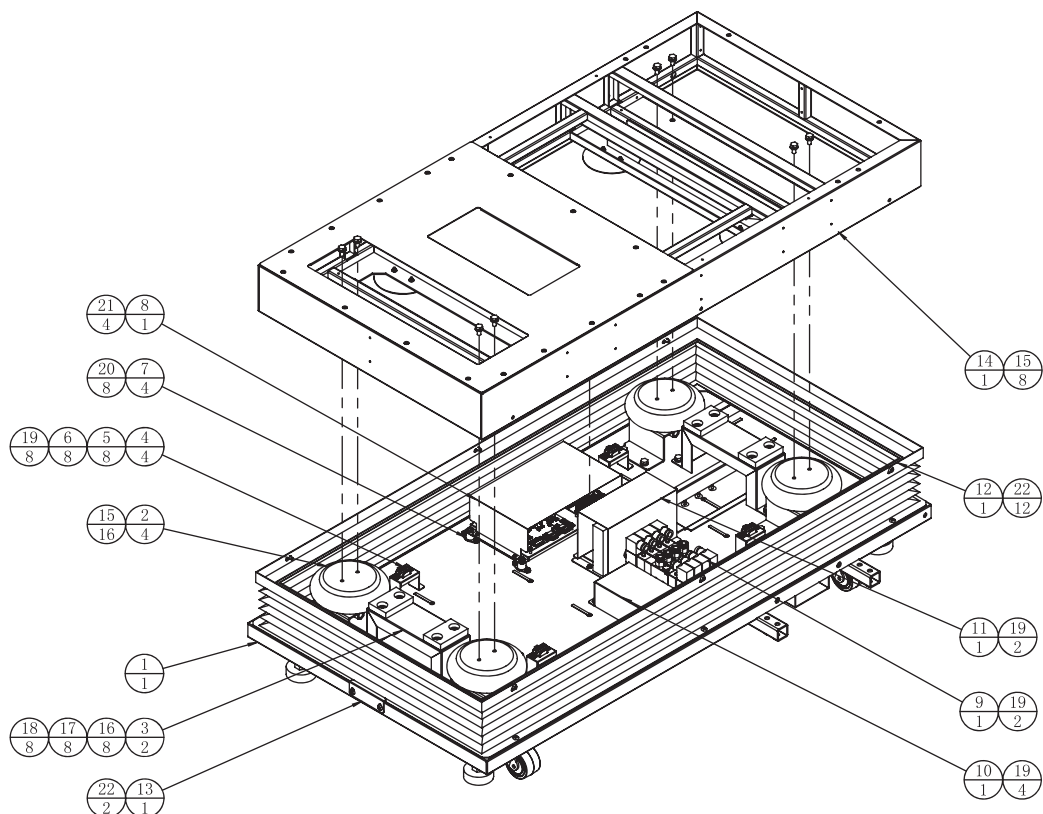

22		cross the big flat head screw	M6*12 (Black)	14	
21		cross recessed fillister head three-combination screw	M6*12 (Black)	4	
20		cross recessed fillister head three-combination screw	M5*12 (Black)	8	
19		cross recessed fillister head three-combination screw	M4*12 (Black)	16	
18		spring washer	M8 (Black)	8	
17		plain washers	φ8*φ16*2.0 (Black)	8	
16		external hex socket screw	M8*50 (Black)	8	
15		Hexagon triple combination	8*16*16*1.5(Black)	24	
14	A9DX-0208000	Platform upper seat		1	1.1.IG39A00310
13	HXD-0200A02	Dust cover plate	SPCC-1.5T	1	1.1.IG19G00280
12	SRH-0200A01	dust cover		1	1.1.WA16C00320
11	A9DX-0207000	Base power box assembly		1	
10	A9DX-0200A01	Solenoid valve cover plate	SPCC-1.2T	1	1.1.IG39A00220
9	A9DX-0206000	Solenoid valve base assembly		1	
8	A9DX-0205000	Base IO board assembly		1	
7		lanhe shaped foot shock		4	1.8.AA000250
6		The nylon washer	WS7-1	8	1.4.DC102210
5		Transistor gasket	TW-102	8	1.4.DC102230
4	A9DX-0204000	Platform sensor assembly		4	
3	A9DX-0203000	Platform support frame assembly		2	
2	A9DX-0202000	Air bag assembly		4	
1	A9DX-0201000	Platform bottom assembly		1	
No.	Draw No.	Name	Material/Spec.	Qty.	Product Code

6.4.1 Platform bottom assembly (A9DX-0201000)

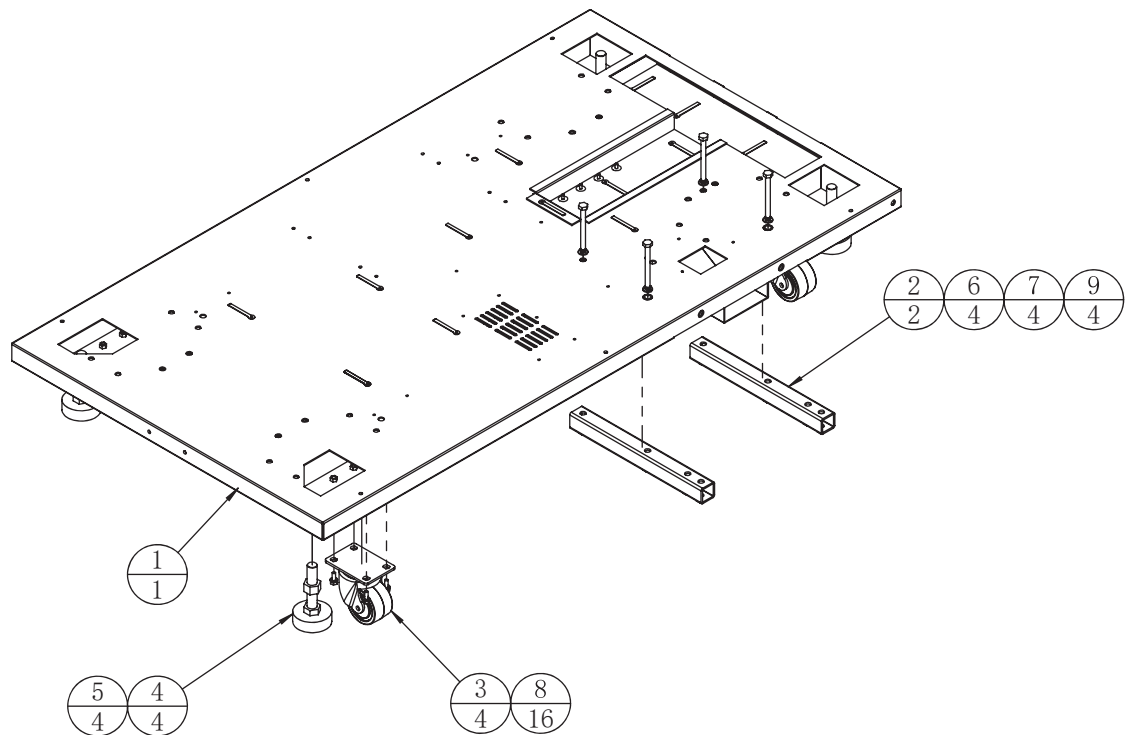

9		spring washer	M8 (Black)	4	
8		Hexagon triple combination	6*16*12*1.2(Black)	16	
7		plain washers	φ8*φ16*2.0 (Black)	4	
6		external hex socket screw	M8*80 (Black)	4	
5		hexagon nut	M16 (Colour)	4	
4		anchor bolt (rubber bottom)	M16*100(Colour)	4	
3		casters	2.5 inch low center of gravity type	4	1.4.JL302520
2	A9DX-0201A02	Connecting pipe of base cashbox	Square tube 30*30*3.0	2	1.1.IG39A00240
1	A9DX-0201A01	Platform base		1	1.1.IG39A00230
No.	Draw No.	Name	Material/Spec.	Qty.	Product Code

6.4.2 Air bag assembly (A9DX-0202000)

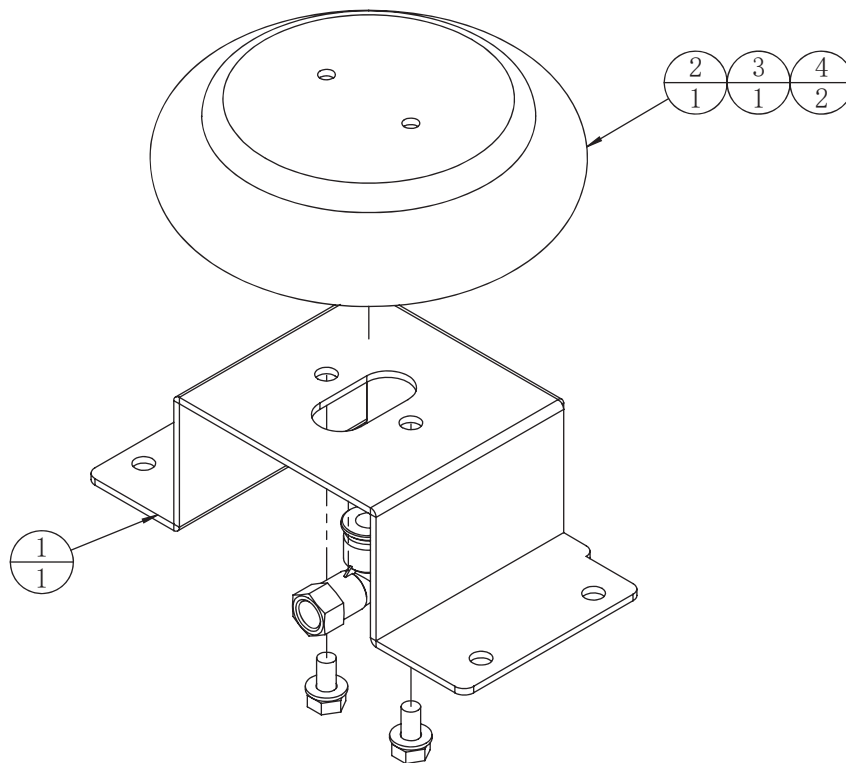

4		Hexagon triple combination	8*16*16*1.5(Black)	2	
3		I type screw thread connector	APL10-02	1	1.4.JG072110
2		air bag	1B5002	1	1.4.QL000020
1	A9DX-0202A01	Airbag base	SPCC-3.0T	1	1.1.IG39A00250
No.	Draw No.	Name	Material/Spec.	Qty.	Product Code

6.4.3 Platform support frame assembly (A9DX-0203000)

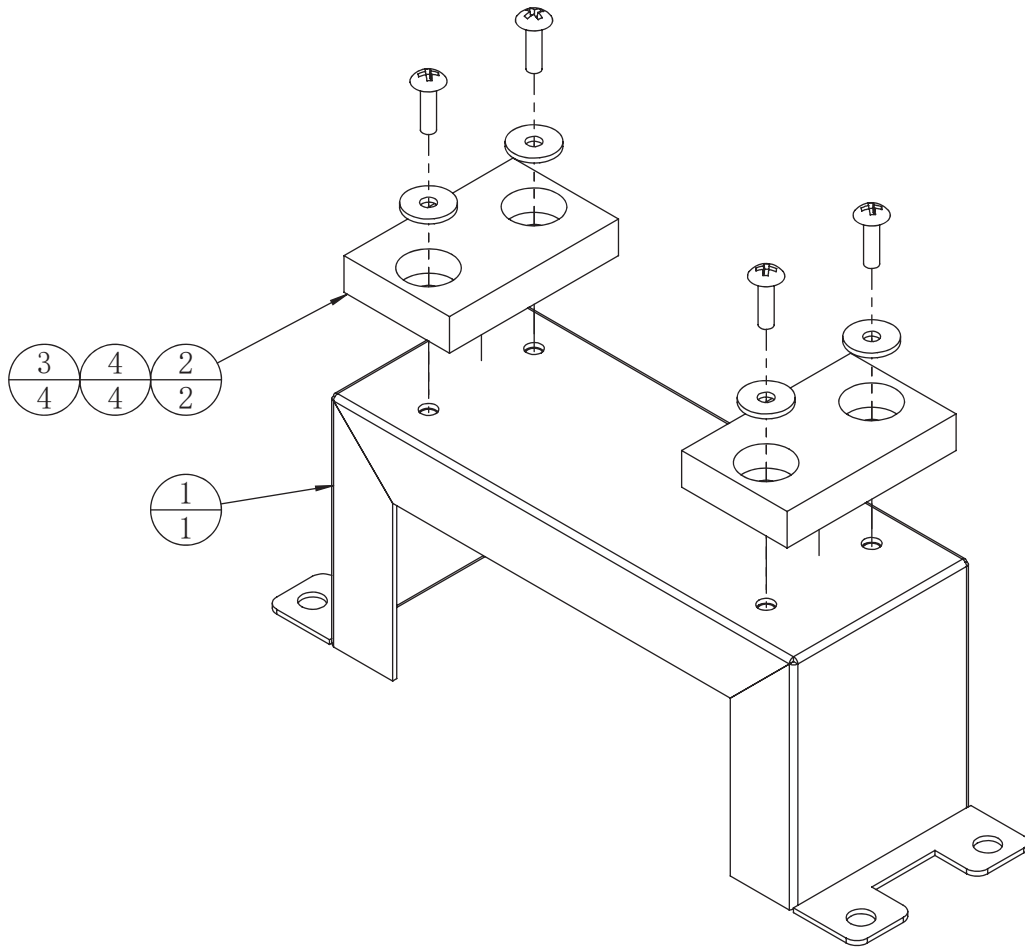

4		plain washers	$\Phi 6 \times \Phi 20 \times 2.0$ (Black)	4	
3		cross the big flat head screw	M6*20 (Black)	4	
2	A9DX-0203C01	Support superior glue	Youlijiao	2	1.8.IG39A00010
1	A9DX-0203A01	Platform support frame	SPCC-2.0T	1	1.1.IG39A00260
No.	Draw No.	Name	Material/Spec.	Qty.	Product Code

6.4.4 Platform sensor assembly (A9DX-0204000)

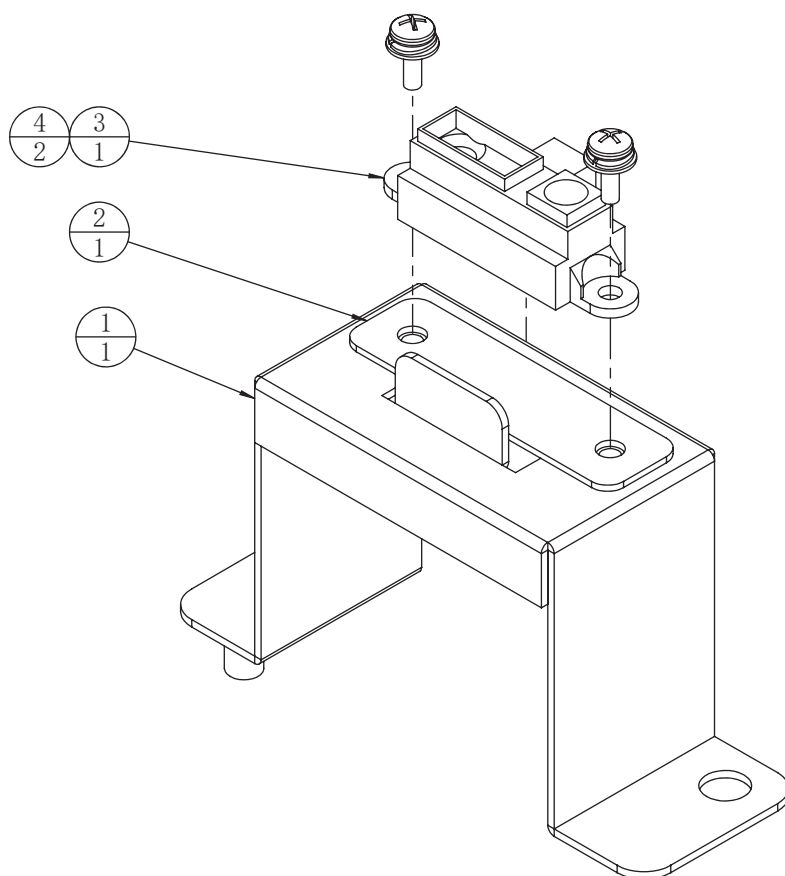

4		cross recessed fillister head three-combination screw	M3*8 (Black)	2	
3		sensor	GP2Y0A41SK0F (5V,4~30cm)	1	1.4.GY100040
2	A9DX-0204D01	Sensor PVC gasket	PVC-1.0T	1	1.7.IG39A00020
1	A9DX-0204A01	Sensor fixing seat	SPCC-1.2T	1	1.1.IG39A00270
No.	Draw No.	Name	Material/Spec.	Qty.	Product Code

6.4.5 Base IO board assembly (A9DX-0205000)

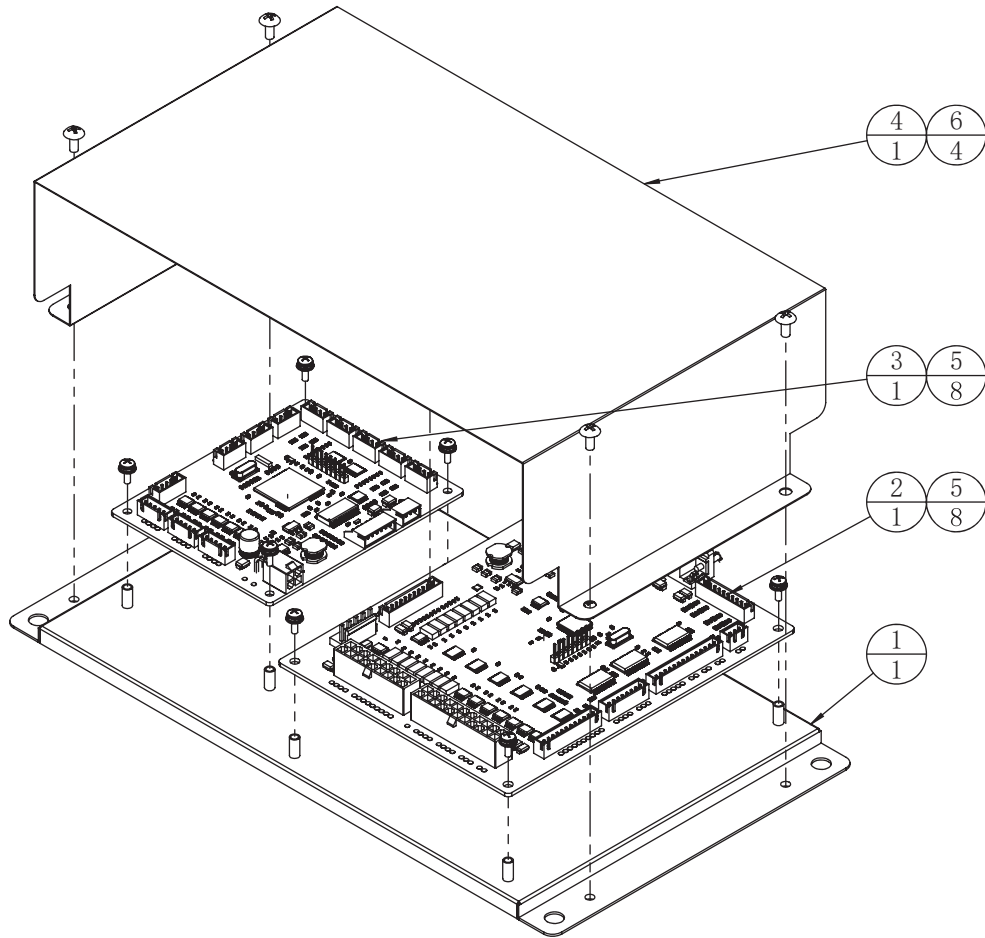

6		cross the big flat head screw	M4*8 (chrome)	4	
5		cross recessed fillister head three-combination screw	M3*8 (chrome)	8	
4	A9DX-0205D01	IO board protective cover	PVC-0.5T	1	1.7.IG39A00030
3	5651-00000170	lamp control board	MU-#-0(RoHS)	1	1.3.IG39A00040
2	5651-00000112	Air compressor system control panel	LP-#-0(ROHS)	1	1.3.IG39A00020
1	A9DX-0205A01	Platform IO board bracket	SECC-1.0T	1	1.1.IG39A00280
No.	Draw No.	Name	Material/Spec.	Qty.	Product Code

6.4.6 Solenoid valve base assembly (A9DX-0206000)

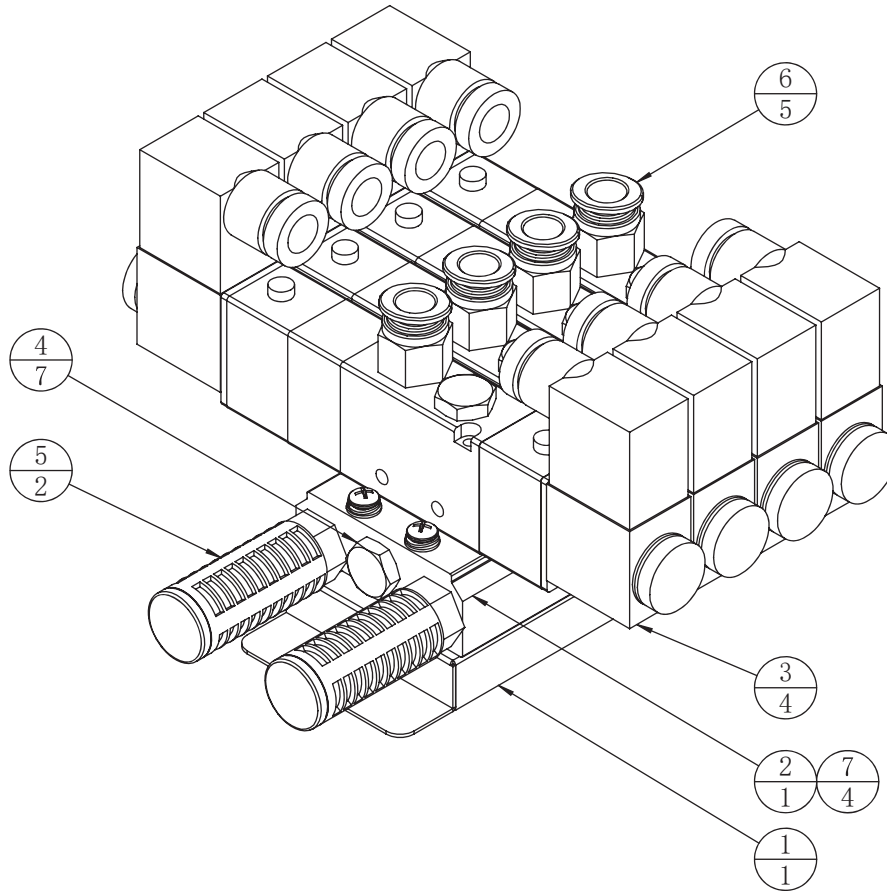

7		cross recessed fillister head three-combination screw	M4*30 (chrome)	4	
6		screw thread direct connector	APC10-02	5	1.4.JG082030
5		silencer	PAL02	2	1.4.YSE00040
4		hose nippler	BZ02	7	1.4.JG09A060
3		solenoid valve	4V230C-08-F	4	1.4.DC300050
2		pneumatic control valve base	200M-4F	1	1.4.QC000030
1	A9DX-0206A01	Electromagnetic valve fixing frame	SECC-1.0T	1	1.1.IG39A00290
No.	Draw No.	Name	Material/Spec.	Qty.	Product Code

6.4.7 Base power box assembly (A9DX-0207000)

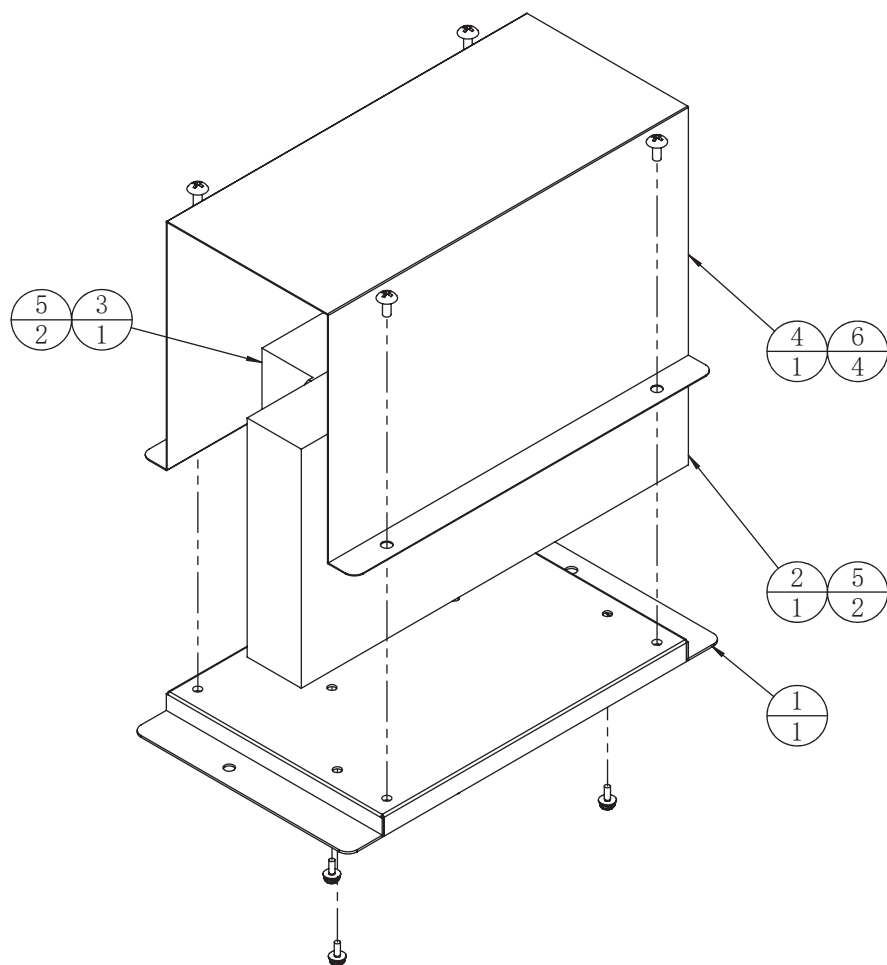

6		cross the big flat head screw	M4*8 (chrome)	4	
5		cross recessed fillister head three-combination screw	M3*8 (chrome)	4	
4	A9DX-0207D01	Protective cover of power box	PVC-0.5T	1	1.7.IG39A00040
3		power supply	LRS-100-12	1	1.4.DY170120
2		power supply	LRS-350-12	1	1.4.DY020060
1	A9DX-0207A01	Platform power support	SECC-1.0T	1	1.1.IG39A00300
No.	Draw No.	Name	Material/Spec.	Qty.	Product Code

6.4.8 Platform gate (A9DX-0208000)

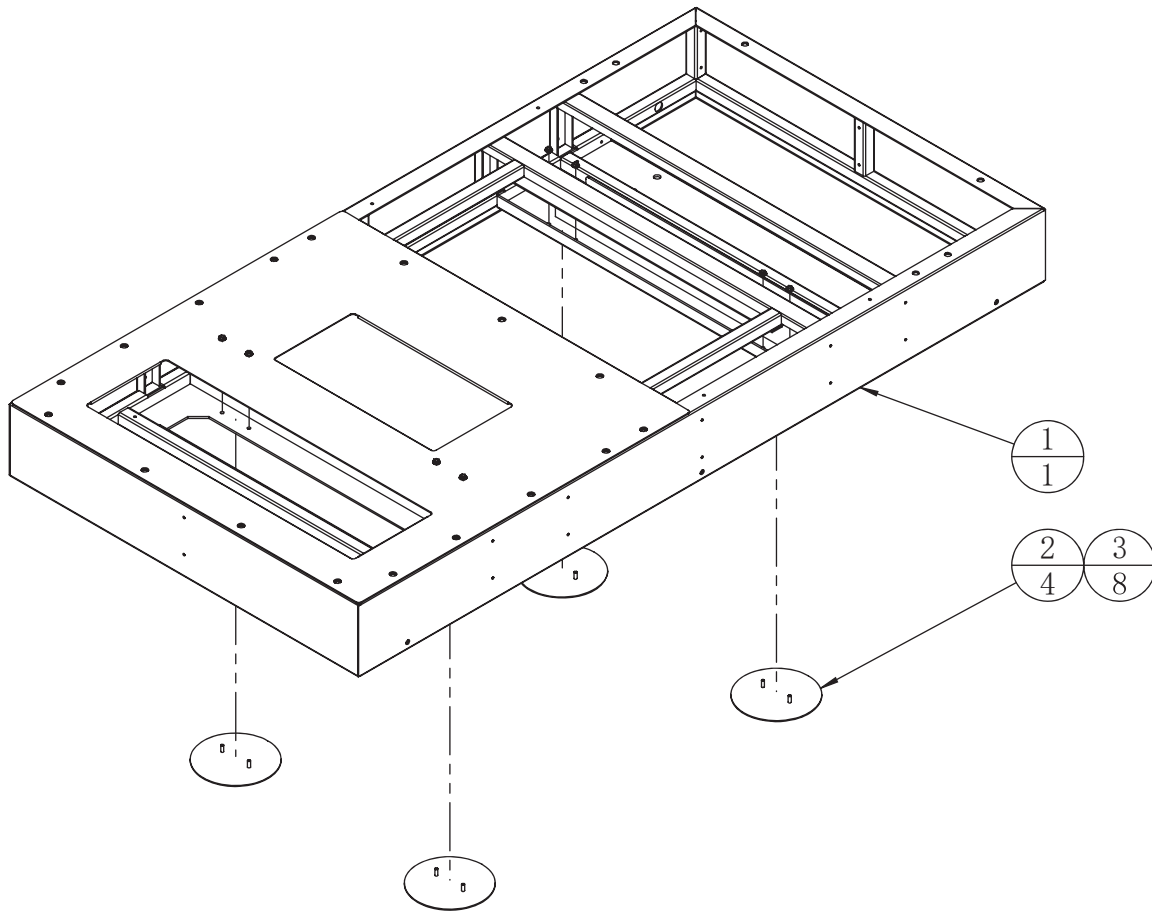

3		hex head cap screw	M4 (Colour)	8	
2	A9DX-0208A02	Circular induction sheet metal	SPCC-1.5T	4	1.1.IG39A00320
1	A9DX-0208A01	Platform upper seat		1	1.1.IG39A00310
No.	Draw No.	Name	Material/Spec.	Qty.	Product Code

6.5 Console assembly(A9DX-0300000)

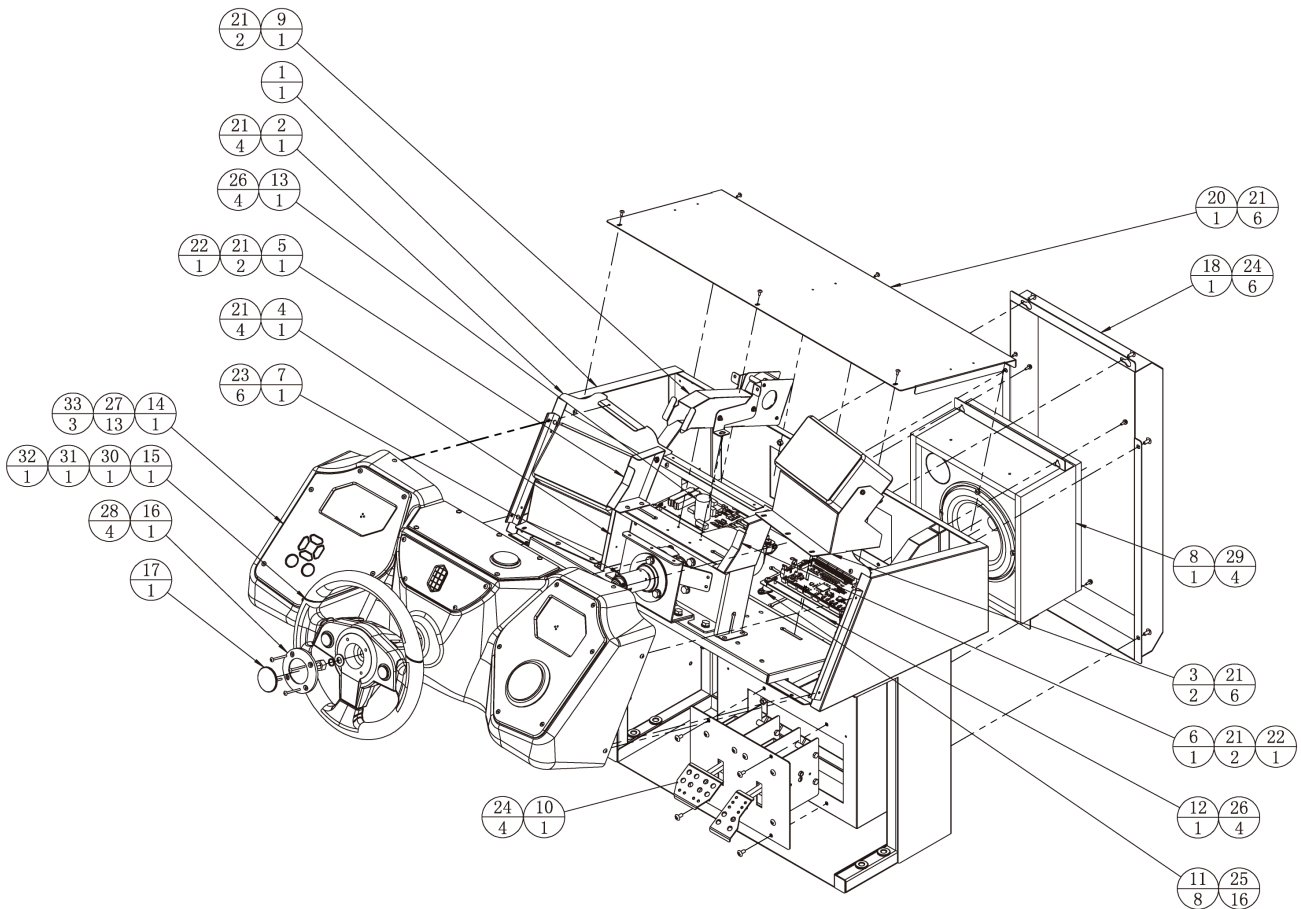
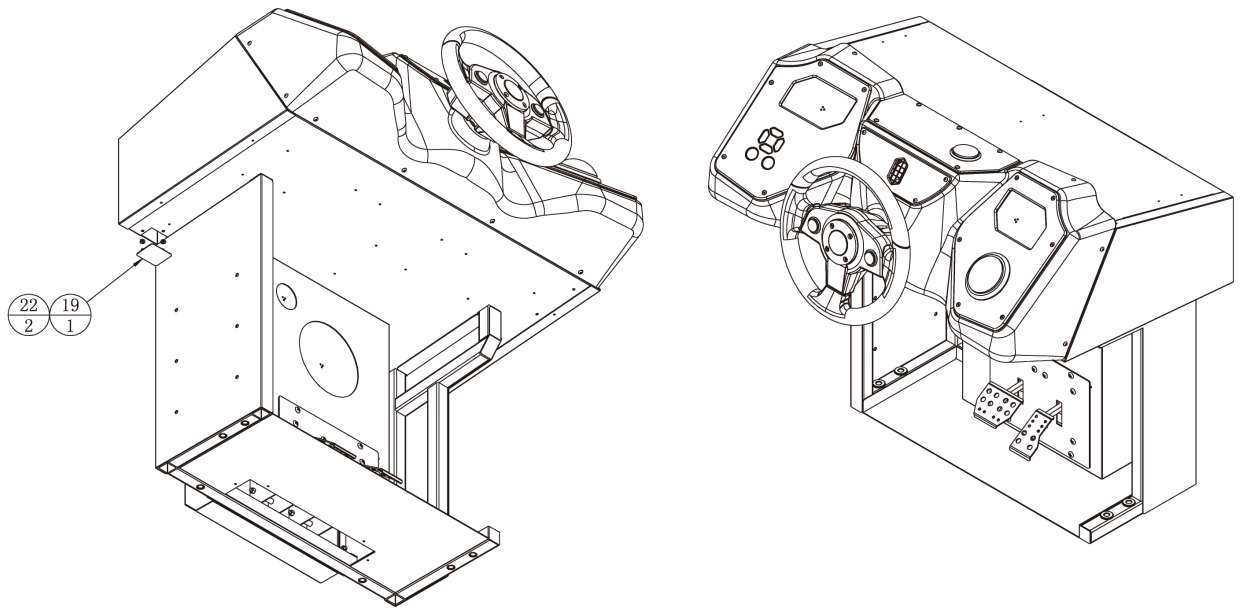

33		flat gasket	Φ4*Φ10*1.0 (chrome)	3	
32		plain washers	φ12*φ24*2.0 (chrome)	1	
31		spring washer	M12 (Black)	1	
30		hexagon nut	M12 (Black)	1	
29		cross recessed fillister head three-combination screw	M4*12 (Black)	4	
28		hex socket cap screws	M4*40 (chrome)	4	
27		hex socket cap screws	M4*12 (chrome)	13	
26		cross recessed fillister head three-combination screw	M6*12 (Black)	8	
25		hex head cap screw	M5 (Colour)	16	
24		cross the big flat head screw	M6*12 (Black)	10	
23		Hexagon triple combination	8*20*16*1.5(Black)	6	
22		hex head cap screw	M4 (Colour)	2	
21		cross the big flat head screw	M4*8 (Black)	26	
20	A9DX-0300A07	Control desk cover plate		1	1.1.IG39A00390
19	A9DX-0300A08	Over-the-wire baffle of banknote machine		1	1.1.IG39A01020
18	A9DX-0300A06	Low speaker back cover	SPCC-1.5T	1	1.1.IG39A00380
17	A9DX-P0014	steering wheel acryl	PMMA-3.0T	1	1.7.IG39A00250
16	A9DX-0300C01	steering wheel decorate plastic	ABS	1	1.8.IG39A00020
15	A9DX-0308000	Steering wheel assembly		1	
14	A9DX-0307000	Plastic-forming console assembly		1	
13	A9DX-0306000	Motor control panel assembly		1	
12	A9DX-0305000	Console IO board assembly		1	
11		lanhe shaped foot shock		8	1.8.AA000250
10	LT-0000000	Vertical induction foot		1	
9	A9DX-0304000	Blower assembly for console		1	
8	A9DX-0303000	Console woofer assembly		1	
7	A9DX-0302000	Steering wheel motor assembly		1	
6	A9DX-0300A05	Steering wheel right bracket	SPCC-1.5T	1	1.1.IG39A00370
5	A9DX-0300A04	Steering wheel left bracket	SPCC-1.5T	1	1.1.IG39A00360
4	A9DX-0300A03	Steering wheel support frame	SPCC-1.5T	1	1.1.IG39A00350
3	A9DX-0301000	Console speaker assembly		2	
2	A9DX-0300A02	Control desk blister support	SPCC-1.5T	1	1.1.IG39A00340
1	A9DX-0300A01	Control desk frame		1	1.1.IG39A00330
No.	Draw No.	Name	Material/Spec.	Qty.	Product Code

6.5.1 Console speaker assembly(A9DX-0301000)

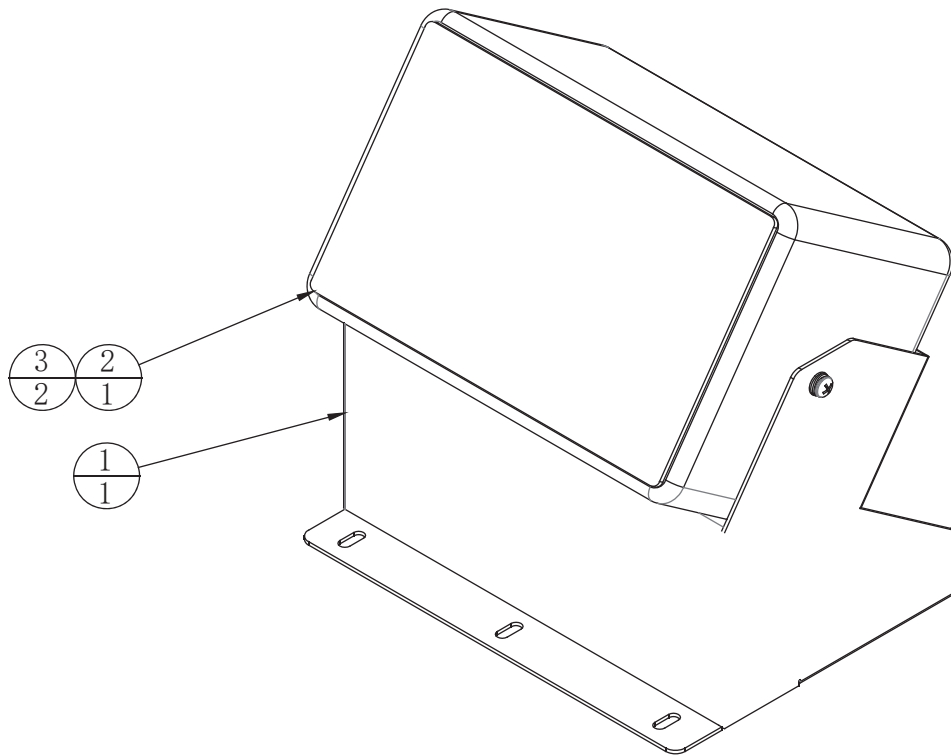

3		cross recessed fillister head three-combination screw	M4*12 (Black)	2	
2		loudspeaker 4"	4 " 4Ω 25W (JK-BX-96HW)	1	1.4.YSD00010
1	A9DX-0301A01	Horn bracket	SPCC-1.5T	1	1.1.IG39A00400
No.	Draw No.	Name	Material/Spec.	Qty.	Product Code

6.5.2 Steering wheel motor assembly(A9DX-0302000)

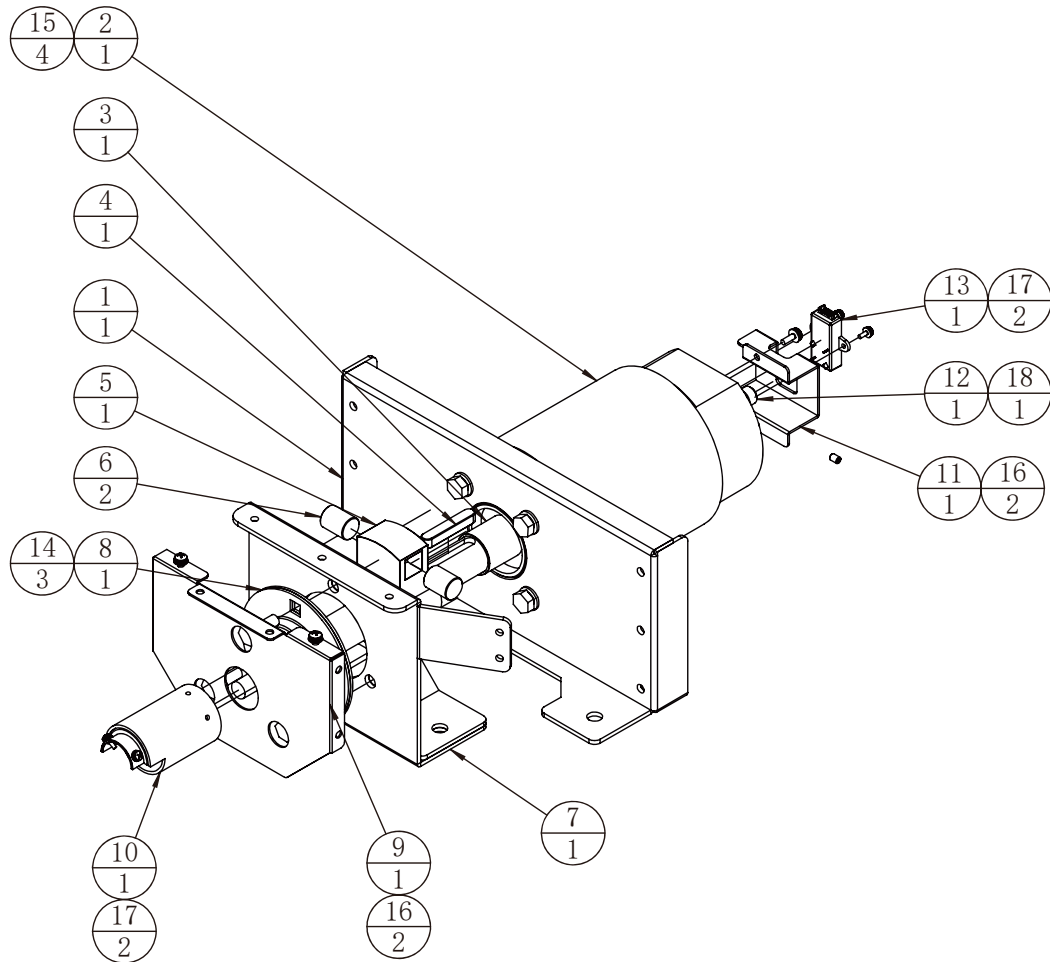

18		Headless hexagon socket screw	M5*6 (Black)	1	
17		cross recessed fillister head three-combination screw	M3*8 (Black)	4	
16		cross recessed fillister head three-combination screw	M4*12 (Black)	4	
15		Hexagon triple combination	8*16*16*1.5(Black)	4	
14		Hexagon triple combination	8*20*16*1.5(Black)	3	
13	0991-50000208	non-contact angle senson assy	Kemite,VR magnet fixed seat + magnet, electromagnetic VR cover + induction plate	1	1.3.IG19A00030#
12	0991-50000208	non-contact angle senson assy	Kemite,VR magnet fixed seat + magnet, electromagnetic VR cover + induction plate	1	1.3.IG19A00030#
11	HXK-0113A02	potentiometer mounted plate	SPCC-1.5T	1	1.1.IG19A00410
10	SD4-0800A01	Assembly welding of steering wheel sleeve		1	1.1.IG04C00350
9	A9DX-0302A03	Steering wheel fixing sheet metal	SPCC-1.2T	1	1.1.IG39DX-1170
8		bearing	PF205	1	1.4.ZC001010
7	A9DX-0302A01	steering wheel brace		1	1.1.IG39A00410
6	SR1-0501A05	Swing axle pads	Youlijijao	2	1.1.WA10A00260
5	SR1-0501A04	motor swing axle	45	1	1.1.WA10A00250
4	SR1-0501A03	Swing axle key	45	1	1.1.WA10A00240
3	SR1-0501A02	motor shaft case	45	1	1.1.WA10A00230
2		dc motors	112ZY100-40	1	1.4.MD100022
1	A9DX-0302A02	motor mounted plate	SPCC-3.0T	1	1.1.IG39A00420
No.	Draw No.	Name	Material/Spec.	Qty.	Product Code

6.5.3 Console woofer assembly(A9DX-0303000)

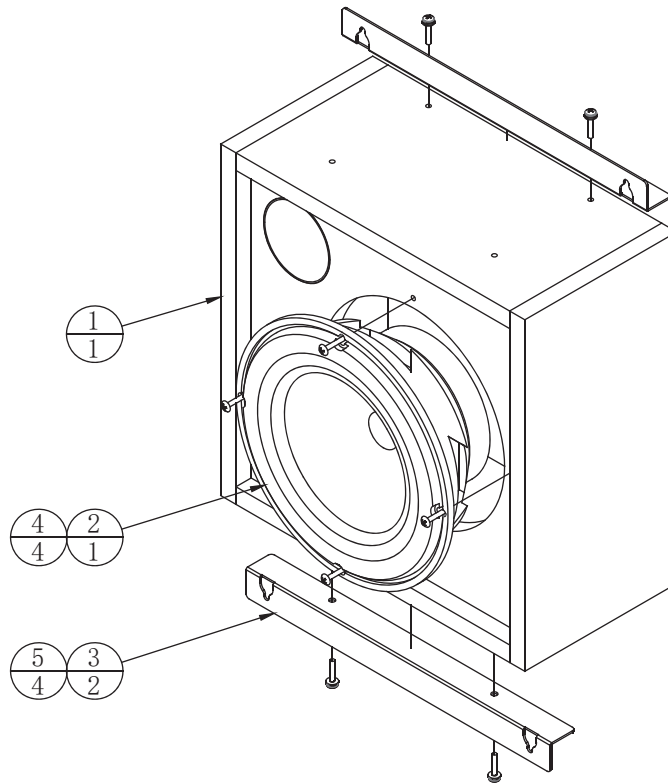

5		cross recessed fillister head three-combination screw	M4*20 (chrome)	4	
4		cross the big flat head screw	M4*25 (Black)	4	
3	A9DX-0303A01	Low sound box fixing plate	SECC-1.5T	2	1.1.IG39A00430
2		woofer	Komet HIT-800W4Ω/60W(with anti-magnetic cover)	1	1.4.YS604010
1	A9DX-0303B01	Bass wooden box		1	1.2.IG39A00070
No.	Draw No.	Name	Material/Spec.	Qty.	Product Code

6.5.4 Blower assembly for console (A9DX-0304000)

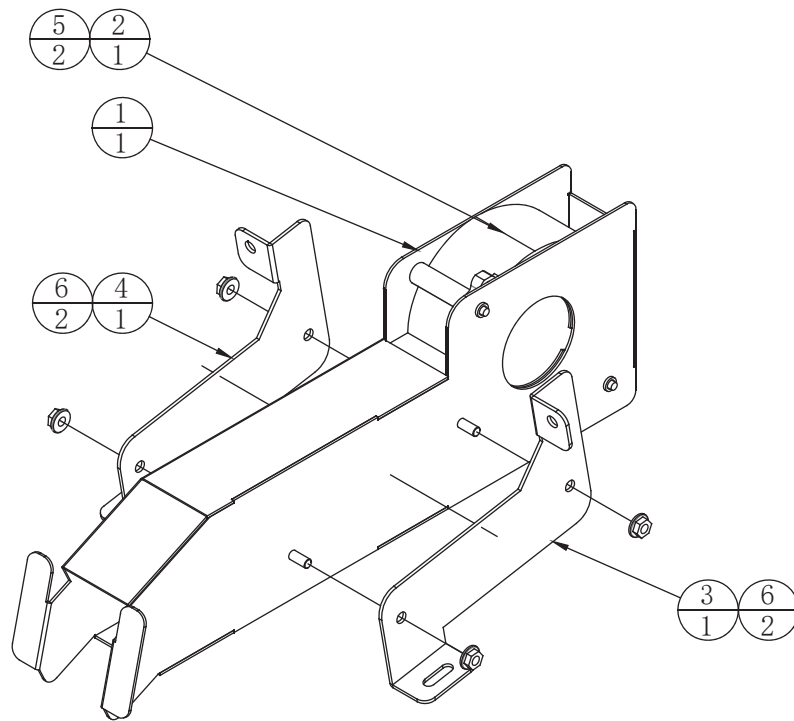

6		hex head cap screw	M4 (Colour)	4	
5		cross the big flat head screw	M4*40 (Black)	2	
4	A9DX-0304A03	Left air outlet pipe bracket	SPCC-1.5T	1	1.1.IG39A00460
3	A9DX-0304A02	Right air outlet pipe bracket	SPCC-1.5T	1	1.1.IG39A00450
2		blower	KD1297PNB1	1	1.4.FS1A0030
1	A9DX-0304A01	Air outlet pipe of console		1	1.1.IG39A00440
No.	Draw No.	Name	Material/Spec.	Qty.	Product Code

6.5.5 Console IO board assembly(A9DX-0305000)

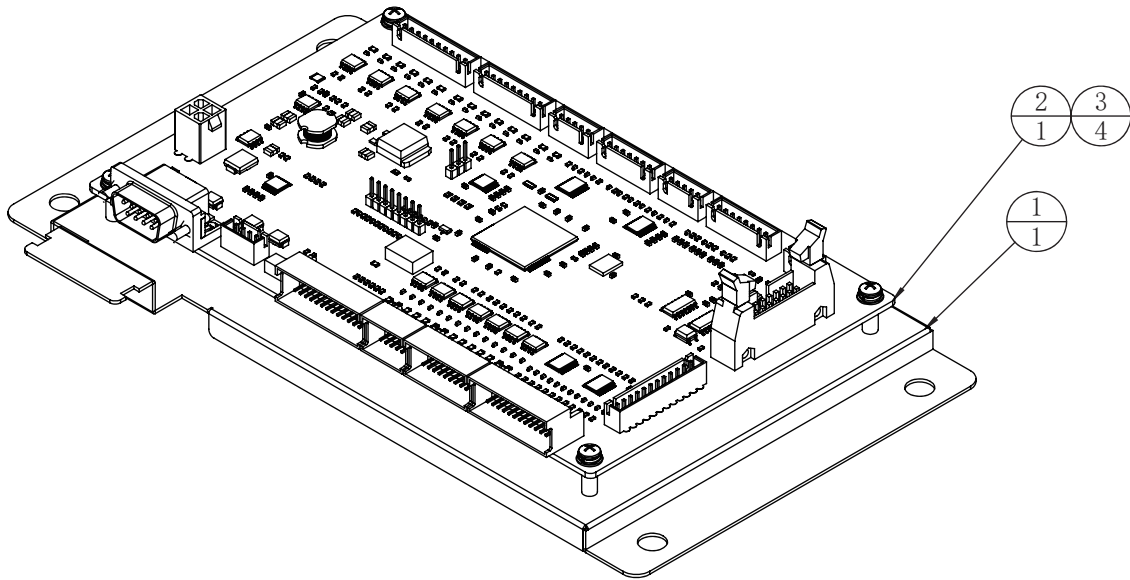

3		cross recessed fillister head three-combination screw	M3*8 (chrome)	4	
2	8651-00000102	I/O board pcb	OL - # 0 (2) (RoHS)	1	1.3.IG39A00010
1	A9DX-0305A01	IO board fixing frame of console	SECC-1.0T	1	1.1.IG39A00470
No.	Draw No.	Name	Material/Spec.	Qty.	Product Code

6.5.6 Motor control panel assembly(A9DX-0306000)

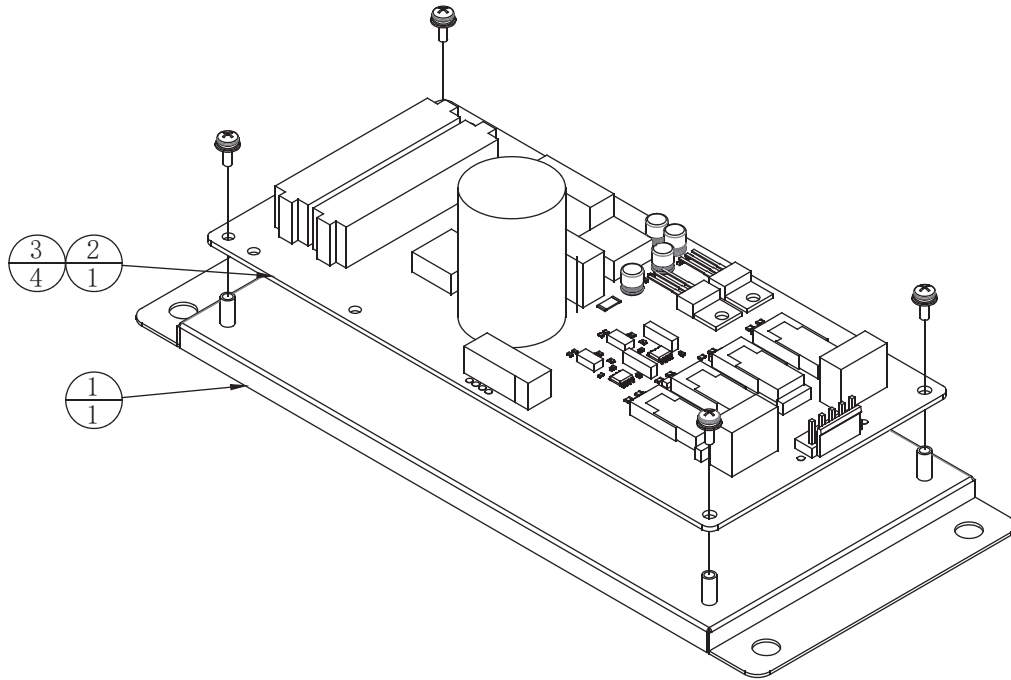

3		cross recessed fillister head three-combination screw	M3*8 (chrome)	4	
2	5651-10000120	control motor board	LQ-A-0_ Cement Resistance (RoHS)	1	1.3.IG39A00030
1	A9DX-0306A01	Motor control board fixing frame	SECC-1.0T	1	1.1.IG39A00480
No.	Draw No.	Name	Material/Spec.	Qty.	Product Code

6.5.7 Plastic-forming console assembly (A9DX-0307000)

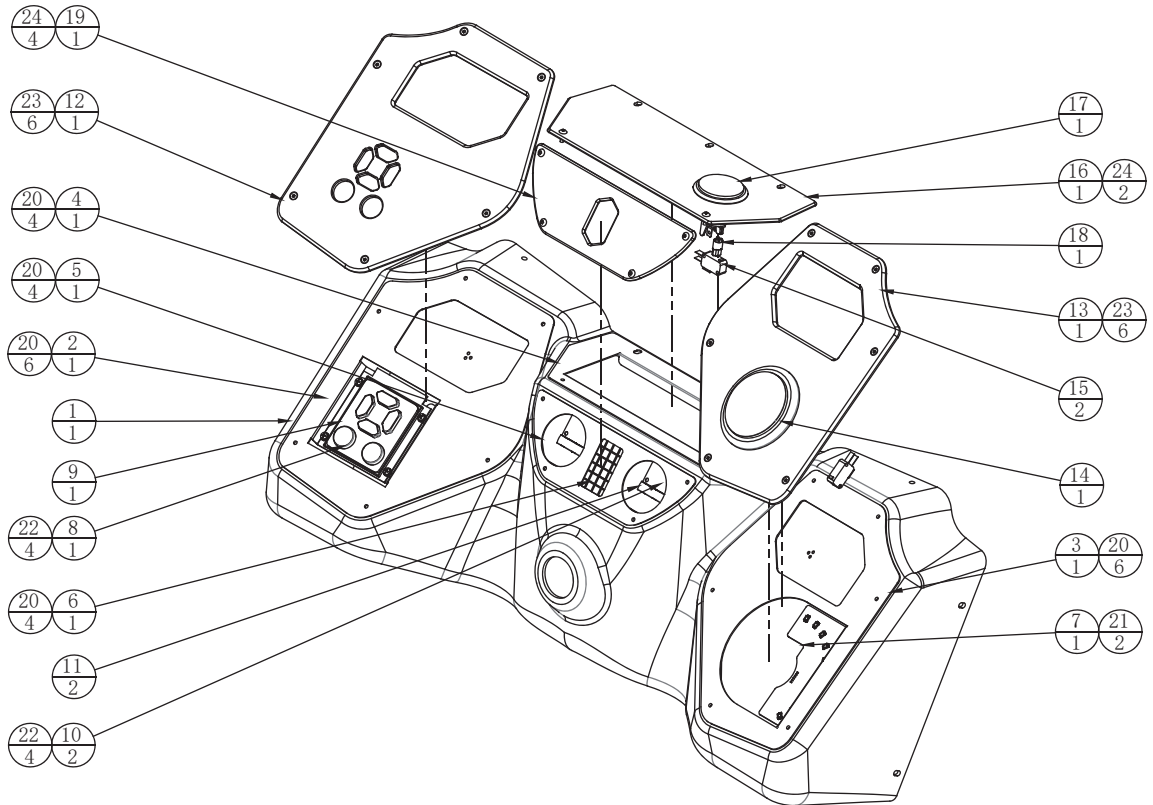

24		hex socket cap screws	M4*12 (chrome)	6	
23		hexagon socket countersunk head screws	M4*12 (chrome)	12	
22		cross recessed fillister head three-combination screw	M4*8 (Black)	8	
21		cross recessed fillister head three-combination screw	M3*8 (chrome)	2	
20		hex head cap screw	M4 (Colour)	24	
19	A9DX-P0008	Control desk instrument decoration	PMMA-3.0T	1	1.7.IG39A00190
18		led lamp for button	12VThree white light(T10 312V-SMD)	1	1.4.AJA01040
17		Round illuminated button (with lamp holder)	Φ60 BLC-TN-BK-C-CW	1	1.4.AJ106031#
16	A9DX-P0007	Acrylic force on top of console	PMMA-3.0T	1	1.7.IG39A00180
15		micro switch	D3V-01-1C23	2	1.4.SW103011
14		convex round button with lamp (including lamp base & smd 3 color led)	BLC-BL-BK-H-CW-D	1	1.4.AJ350020
13	A9DX-P0006	Control panel right acrylic	PMMA-5.0T	1	1.7.IG39A00170
12	A9DX-P0005	Control panel left acrylic	PMMA-5.0T	1	1.7.IG39A00160
11		5050 strip light	DC12V 60 Light L=50mm	2	1.4.ZM9E1062
10	A9DX-0307A06	Fixing frame for control lamp strip	SECC-1.2T	2	1.1.IG39A00540
9	SD5-0110E01	Direction key cushion	EVA-3.0T	1	1.9.HM060370
8		(film) switch button	MCC-2492	1	1.4.AJN01022
7		led lamp board for button	GK-514-011	1	1.4.IC901860
6	A9DX-0307A05	Tuyere network	SPCC-1.0T	1	1.1.IG39A00530
5	A9DX-0307A04	Control desk air outlet sheet metal	SPCC-1.2T	1	1.1.IG39A00520
4	A9DX-0307A03	Xi su kong tai car body panel repair	SPCC-1.2T	1	1.1.IG39A00510
3	A9DX-0307A02	Right console screen board		1	1.1.IG39A00500
2	A9DX-0307A01	Left console screen board		1	1.1.IG39A00490
1	A9DX-0307C01	Plastic control desk	Black ABS composite panel	1	1.8.IG39A00030
No.	Draw No.	Name	Material/Spec.	Qty.	Product Code

6.5.8 Steering wheel assembly(A9DX-0308000)

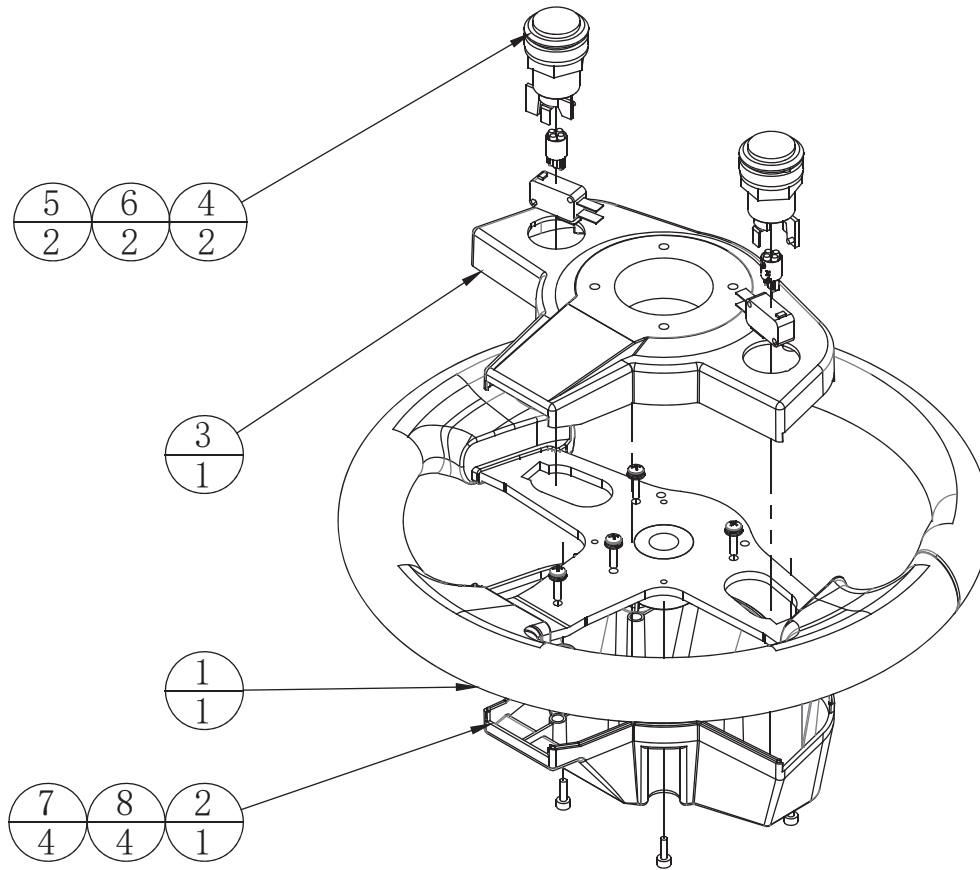

8		socket head cap screws	M4*12 (chrome)	4	
7		cross recessed fillister head three-combination screw	M4*16 (chrome)	4	
6		led lamp for button	12VThree white light(T103W-12V-SMD)	2	1.4.AJA01040
5		micro switch	D3V-01-1C3	2	1.4.SW103011
4		Round illuminated button (with lamp holder)	BLC-TN-A-ES-1CR-2CW-B 15	2	1.4.AJ103016
3	SD3-11-00-03	steering wheel upper cover	ABS Black T=2.5	1	1.8.IG04A030
2	SD3-11-00-02	steering wheel lower cover	ABS Black T=2.5	1	1.8.IG04A020
1	SD4-1000A01	steering wheel		1	1.1.IG04C00370
No.	Draw No.	Name	Material/Spec.	Qty.	Product Code

6.6 Car body assembly(A9DX-0400000)

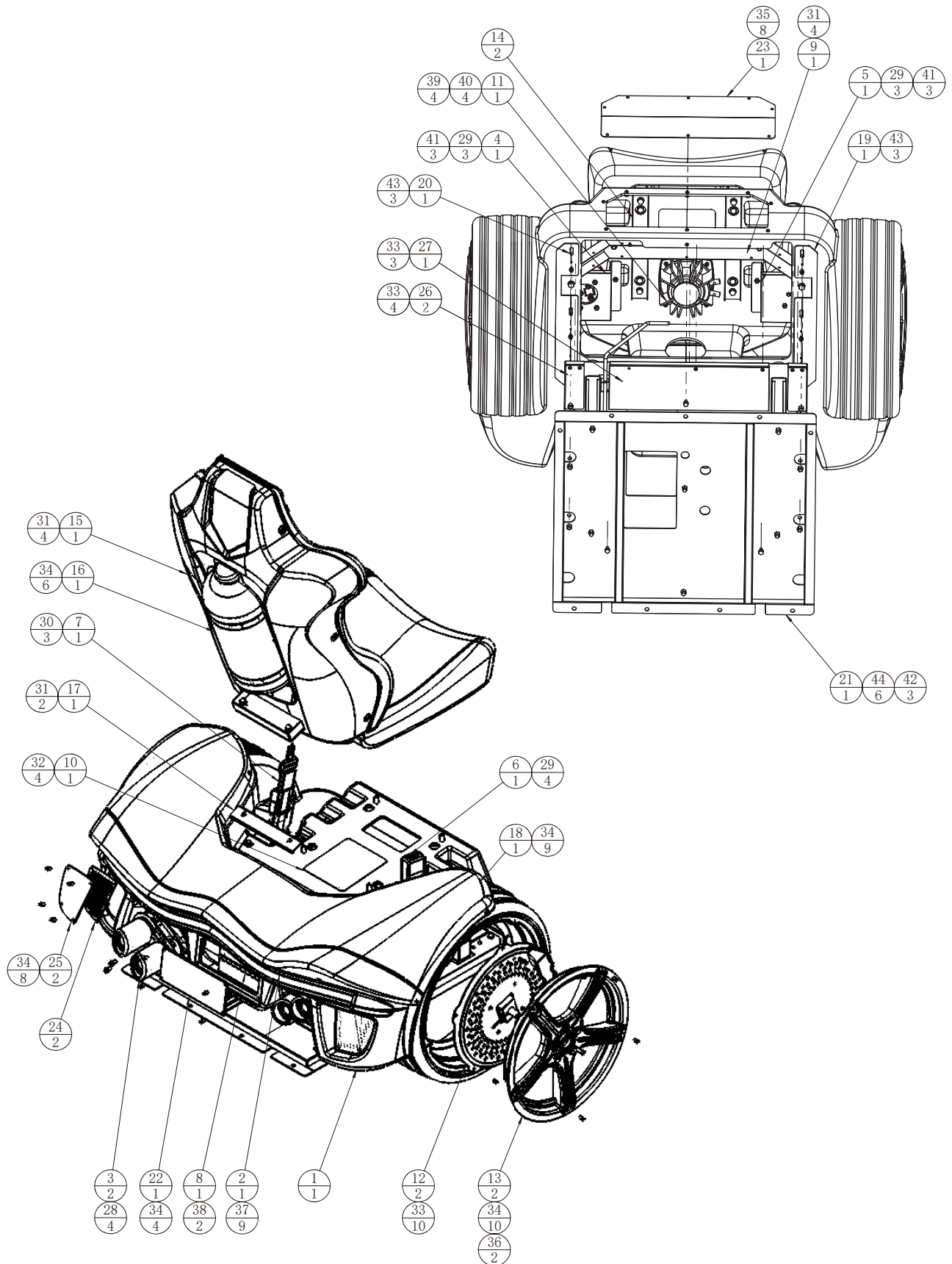

44		self-locking nut	M8 (Galvanized)	6	
43		Cross countersunk head screw	M4*16 (black)	6	
42		Outer hexagonal triple combination	6*14*12*1.2(black)	3	
41		Flat washer	Φ6*Φ20*2.0 (black)	6	
40		Flat washer	Φ4*Φ10*1.0 (Chrome)	4	
39		self-locking nut	M4 (Galvanized)	4	
38		Hexagon socket large flat head screw	M4*12 (black)	2	
37		Cross countersunk head tapping screw	M3*10 (Chrome)	9	
36		Hexagon socket large flat head screw	M6*20 (Chrome)	2	
35		Hexagon socket large flat head screw	M4*12 (black)	8	
34		Hexagon socket large flat head screw	M4*12 (Chrome)	37	
33		Cross large flat head screw	M4*8 (black)	17	
32		Hexagon flange nut	M4 (Color)	4	
31		Outer hexagonal triple combination	8*30*16*1.5(black)	10	
30		self-locking nut	M6 (Galvanized)	3	
29		Outer hexagonal triple combination	6*20*12*1.2(black)	10	
28		Cross round head three combination screws	M5*16(black)	4	
27	A9DX-0400A10	Slide rail cover plate II	SPCC-1.0T	1	1.1.IG39A00640
26	A9DX-0400A09	Slide rail cover plate I	SPCC-1.0T	2	1.1.IG39A00630
25	A9DX-0400D02	Acrylic for rear decorative mesh plate	PMMA-3.0T	2	1.7.IG39A00050
24	A9DX-0400A07	Automobile decoration network	SPCC-1.2T	2	1.1.IG39A00610
23	A9DX-0400A08	Seat maintenance door	SPCC-1.5T	1	1.1.IG39A00620
22	A9DX-P0009	plate number acryl	PMMA-3.0T	1	1.7.IG39A00200
21	A9DX-0409000	Long slide rail group		1	
20	A9DX-0400A12	Base fixing plate 2	SPCC-2.5T	1	1.1.IG39A01040
19	A9DX-0400A11	Base fixing plate 1	SPCC-2.5T	1	1.1.IG39A01030
18	A9DX-0400C02	Plastic tail wing	Black ABS composite panel	1	1.8.IG39A00050
17	A9DX-0400A06	Seat back fixing plate	SPCC-1.5T	1	1.1.IG39A00600
16	A9DX-0408000	Nitrogen cylinder assembly		1	
15	A9DX-0407000	Seat assembly		1	
14	A9DX-0400A05	Rotational molding body reinforcing plate	SECC-1.5T	2	1.1.IG39A00590
13	A9DX-0406000	External contour assembly		2	
12	A9DX-0405000	Internal assembly of wheel		2	
11		Low-frequency vibrator	4Ω/50W	1	1.4.YSA00010
10	A9DX-0400A02	Vibration horn fixing plate	SECC-1.5T	1	1.1.IG39A00560
9	A9DX-0400A01	Car body support frame	SPCC-1.5T	1	1.1.IG39A00550
8	A9DX-0404000	License plate light assembly		1	
7	A9DX-0403000	Safety belt assembly		1	
6	A9DX-0402000	Buckle-up assembly		1	
5	A9DX-0400A04	Seat belt fixing plate	SPCC-1.5T	1	1.1.IG39A00580
4	A9DX-0400A03	Safety belt reinforcing bracket	SPCC-1.5T	1	1.1.IG39A00570
3	A9DX-0401000	Buckle-up assembly		2	
2		5050 soft strip lamp (WS2815 chip)	DC12V L=1000mm	1	1.4.ZM9E2090
1	A9DX-0400C01	Rotational molding car body	Black LDPE	1	1.8.IG39A00040
No.	Draw No.	Name	Material/Spec.	Qty.	Product Code

6.6.1 Buckle-up assembly (A9DX-0401000)

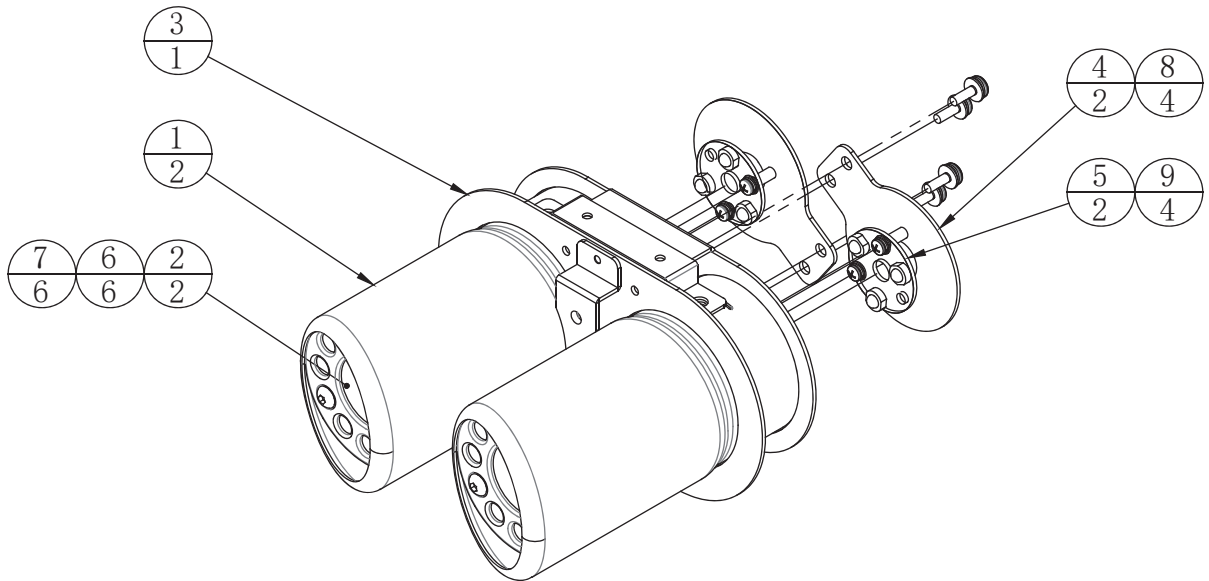

9		cross recessed fillister head three-combination screw	M3*8 (chrome)	4	
8		cross recessed fillister head three-combination screw	M4*12 (chrome)	4	
7		hex head cap screw	M4 (Colour)	6	
6		hex socket cap screws	M4*16 (chrome)	6	
5		round pcb with led	DC12V blue	2	1.4.ZM9G0010
4	A9DX-0401A02	Exhaust pipe lamp plate frame	SECC-1.5T	2	1.1.IG39A00660
3	A9DX-0401A01	Exhaust pipe fixing frame		1	1.1.IG39A00650
2	HXK-0204D01	exhaust pipe decorative acryl	PMMA-3.0T	2	1.7.IG19A00050
1		exhaust pipe		2	1.4.JG09C010
No.	Draw No.	Name	Material/Spec.	Qty.	Product Code

6.6.2 Buckle-up assembly(A9DX-0402000)

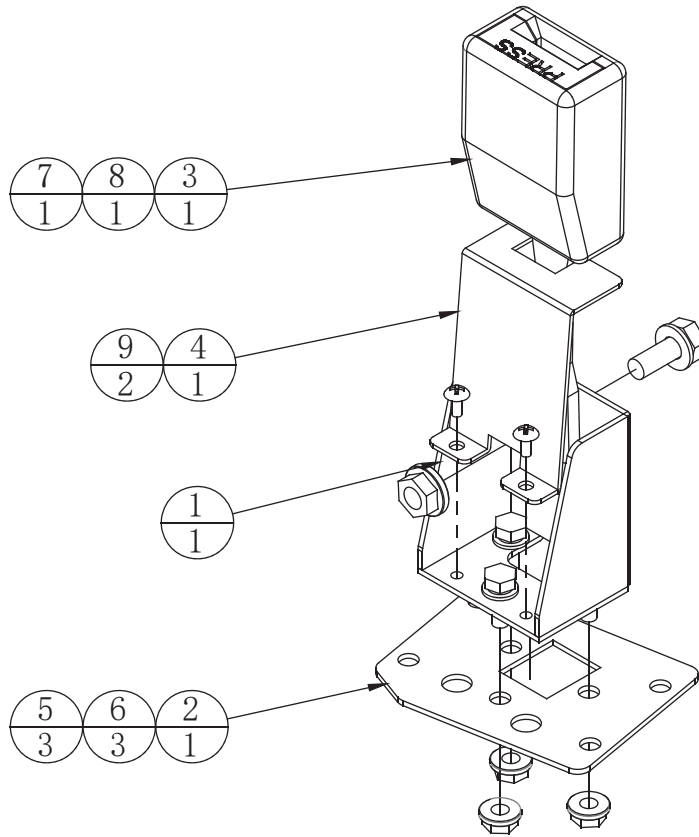

9		cross the big flat head screw	M4*8 (Black)	2	
8		Hexagon triple combination	8*20*16*1.5(Black)	1	
7		hex head cap screw	M8 (Colour)	1	
6		Hexagon triple combination	6*16*12*1.2(Black)	3	
5		hex head cap screw	M6 (Colour)	3	
4	A9DX-0402A03	Seat belt outer cover	SPCC-1.5T	1	1.1.IG39A00690
3		Two-point safety belt (with spring)	Self-locking two-point safety belt with wire normally open + reduction sleeve)	1	1.4.AQ000041
2	A9DX-0402A02	Seat belt floor	SPCC-2.0T	1	1.1.IG39A00680
1	A9DX-0402A01	Seat belt fixing base	SPCC-2.0T	1	1.1.IG39A00670
No.	Draw No.	Name	Material/Spec.	Qty.	Product Code

6.6.3 Safety belt assembly (A9DX-0403000)

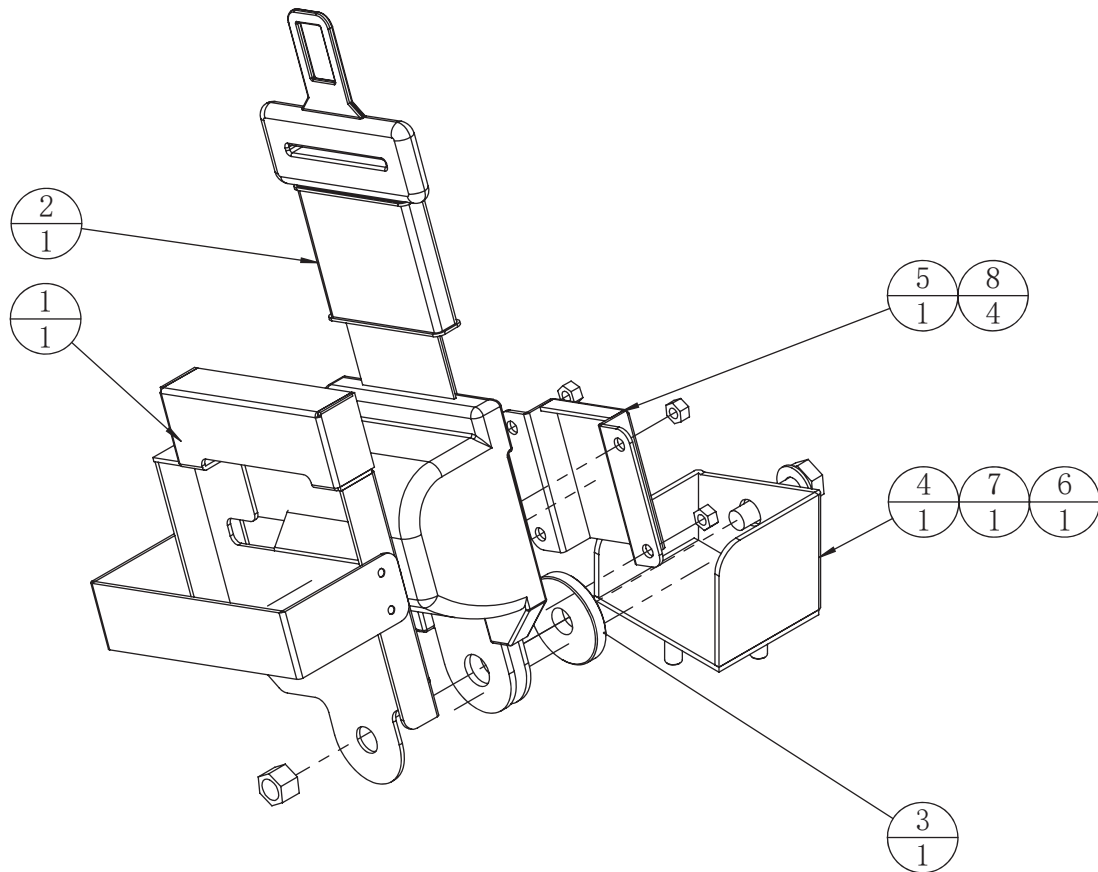

8		Self-Locking Nuts	M4 (Galvanization)	4	
7		Hexagon triple combination	8*30*16*1.5(Black)	1	
6		Self-Locking Nuts	M8 (Galvanization)	1	
5	A9DX-0403A05	Seat belt sleeve limit plate	SPCC-1.5T	1	1.1.IG39A01050
4	A9DX-0403A03	Seat belt bracket 3	SPCC-2.0T	1	1.1.IG39A00720
3	A9DX-0403A04	Seat belt gasket	Q235	1	1.1.IG39A00730
2		Two-point safety belt (with spring)	Self-locking two-point safety belt with wire normally open + reduction sleeve)	1	1.4.AQ000041
1	A9DX-0403A01	Seat belt bracket 1		1	1.1.IG39A00700
No.	Draw No.	Name	Material/Spec.	Qty.	Product Code

6.6.4 License plate light assembly(A9DX-0404000)

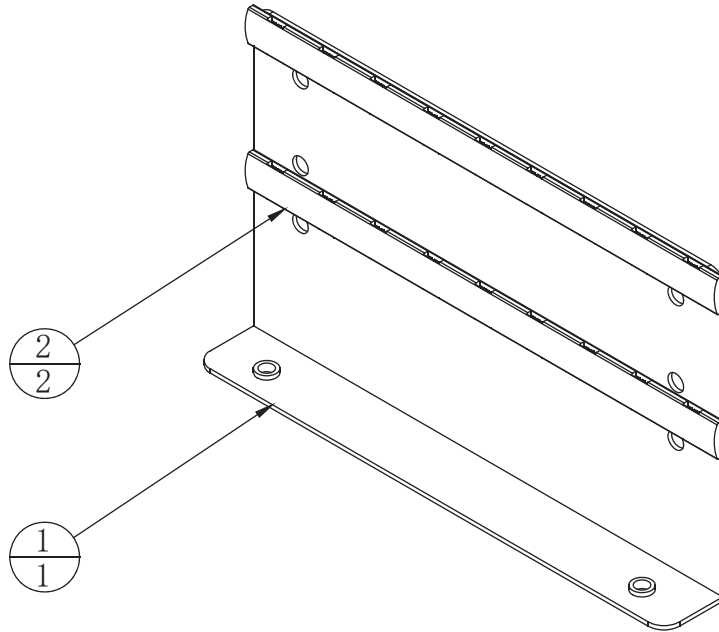

2		5050 strip light	DC12V 60 Light L=150mm	2	1.4.ZM9E1075
1	A9DX-0404A01	License plate lighting fixing plate	SPCC-1.2T	1	1.1.IG39A00740
No.	Draw No.	Name	Material/Spec.	Qty.	Product Code

6.6.5 Internal assembly of wheel(A9DX-0405000)

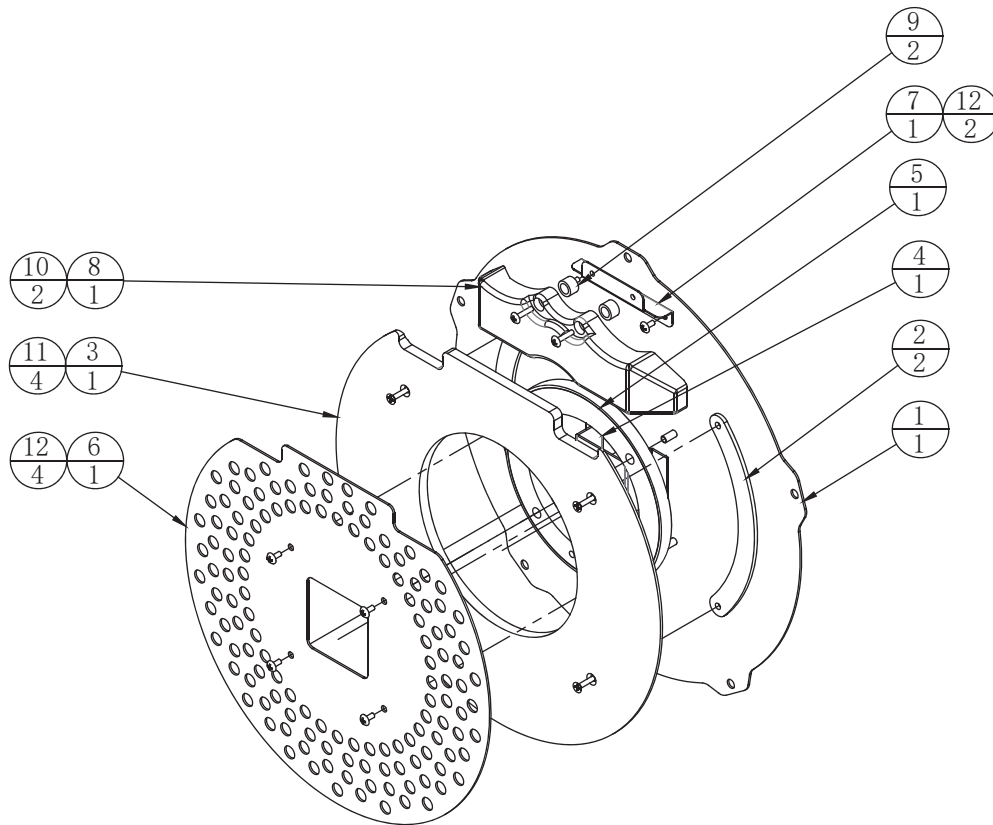

12		cross the big flat head screw	M4*8 (chrome)	6	
11		cross recessed countersunk head screws	M4*16 (chrome)	4	
10		cross the big flat head screw	M4*16 (chrome)	2	
9	A9DX-0406A02	Wheel frame bushing	Q235	2	1.1.IG39A00790
8		Brake cover	yellow	1	1.8.AA000290
7	A9DX-0405A02	Brake cover fixing plate	SPCC-1.2T	1	1.1.IG39A00760
6	A9DX-0405A03	Wheel frame decorative plate	SUS304-1.5T	1	1.1.IG39A00770
5		5050 strip light	DC12V RGB60 L=500mm	1	1.4.ZM9E1080
4	A9DX-0405D03	Disc acrylic plate	PMMA-10.0T	1	1.7.IG39A00070
3	A9DX-P0010	Wheel dotting decoration	PMMA-8.0T	1	1.7.IG39A00210
2	A9DX-0405D02	Acrylic gasket for disc	PMMA-3.0T	2	1.7.IG39A00060
1	A9DX-0405A01	Wheel frame inner ring fixing plate		1	1.1.IG39A00750
No.	Draw No.	Name	Material/Spec.	Qty.	Product Code

6.6.6 External contour assembly(A9DX-0406000)

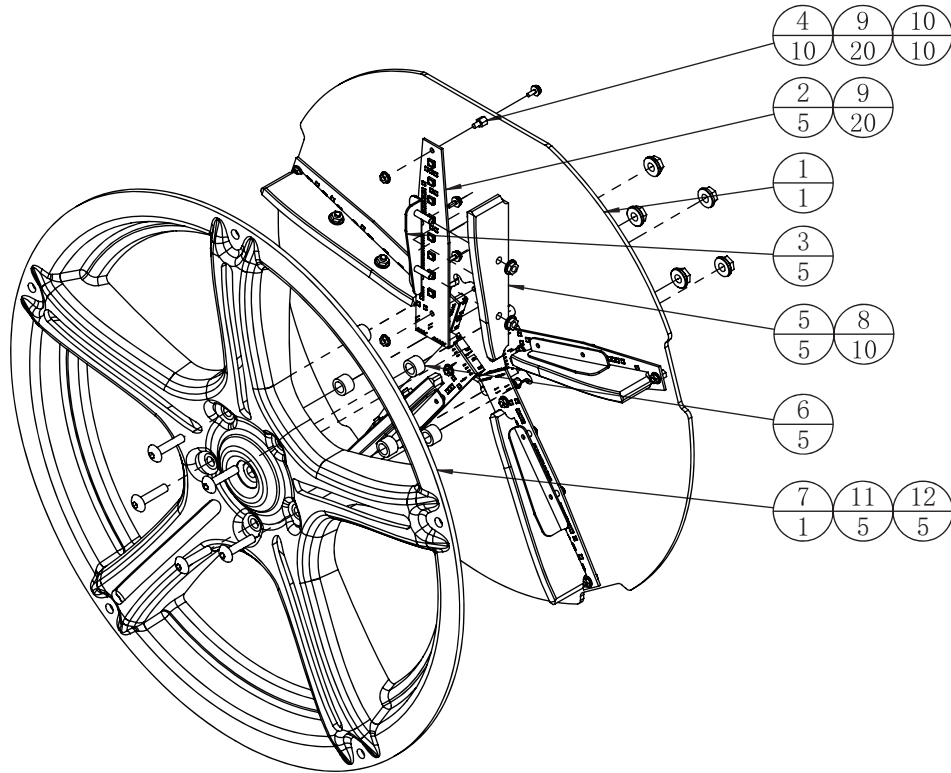

13		hex head cap screw	M6 (Colour)	5	
12		hex socket cap screws	M6*25 (chrome)	5	
11		hex head cap screw	M3 (Colour)	10	
10		cross recessed fillister head three-combination screw	M3*16 (chrome)	10	
9		cross recessed fillister head three-combination screw	M3*8 (chrome)	10	
8		hex head cap screw	M4 (Colour)	10	
7	A9DX-0406C01	Plastic wheel frame	ABS	1	1.8.IG39A00060
6	A9DX-0406A02	Wheel frame bushing	Q235	5	1.1.IG39A00790
5	A9DX-0406D02	Light-guiding acrylic board	PMMA-8.0T	5	1.7.IG39A00090
4		Single hole hexagonal copper stud	Column (M3*5)/ tooth (M3*5)	10	
3	A9DX-0406A01	Tyre light guide bracket	SPCC-1.2T	5	1.1.IG39A00780
2		Wheel frame lamp panel		5	1.4.IC903220
1	A9DX-0406D01	Rim protection acrylic	PMMA-3.0T	1	1.7.IG39A00080
No.	Draw No.	Name	Material/Spec.	Qty.	Product Code

6.6.7 Seat assembly (A9DX-0407000)

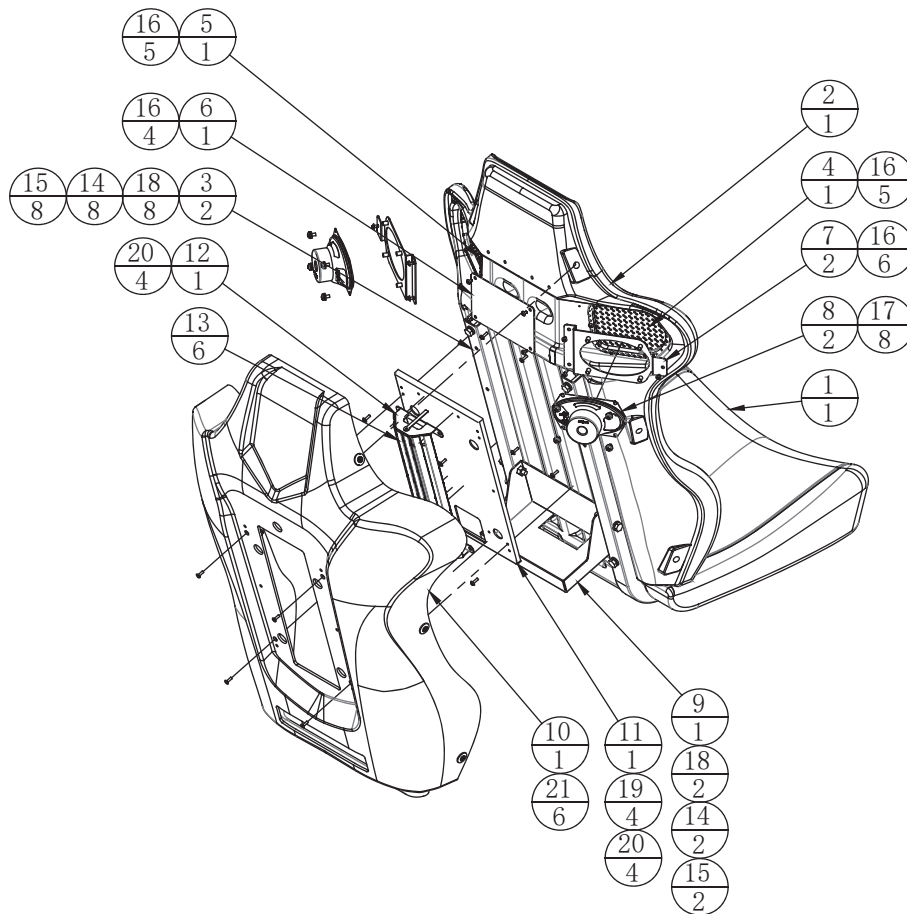

21		plastic screw		6	
20		cross the big flat head screw	M4*12 (Black)	8	
19		cross recessed countersunk head screws	M4*12 (chrome)	4	
18		external hex socket screw	M8*50 (Black)	10	
17		cross recessed fillister head three-combination screw	M5*10 (chrome)	8	
16		cross the big flat head self-drilling screw	M4*8 (chrome)	20	
15		plain washers	φ8*φ16*2.0 (Black)	10	
14		spring washer	M8 (Black)	10	
13		5050 stripe light (LPD6803 chip) (double head with plug)	DC12V RGB30 L=300mm	6	1.4.ZM9E0536
12	A9DX-0407A05	Gas cylinder lamp bar rack	SPCC-1.2T	1	1.1.IG39A00840
11	A9DX-0407A04	Seat back reinforcing bracket	SPCC-2.0T	1	1.1.IG39A00830
10	A9DX-0407C02	Seat back blister	Black ABS composite panel	1	1.8.IG39A00080
9	A9DX-0407A03	Seat back fixing bracket	SPCC-2.0T	1	1.1.IG39A00820
8		ellipse antimagnetic speaker	3*5吋8Ω/15W	2	1.4.YS300010
7	A9DX-0407A02	Seat horn fixing frame	SPCC-1.5T	2	1.1.IG39A00810
6	A9DX-0407A01	Seat shielding sheet metal	SPCC-1.5T	1	1.1.IG39A00800
5		seat speaker cover r	screen-1.0T	1	1.1.IG041001
4		seat speaker cover l	screen-1.0T	1	1.1.IG041000
3	HXD-0302A01	seat bend	Square tube 30*2/Q235	2	1.1.IG19G00710
2	SD3-07-01-03	seat back cushion		1	1.8.IG04A080
1	A9DX-0407C01	Blow molded seat cushion	Black ABS	1	1.8.IG39A00070
No.	Draw No.	Name	Material/Spec.	Qty.	Product Code

6.6.8 Nitrogen cylinder assembly(A9DX-0408000)

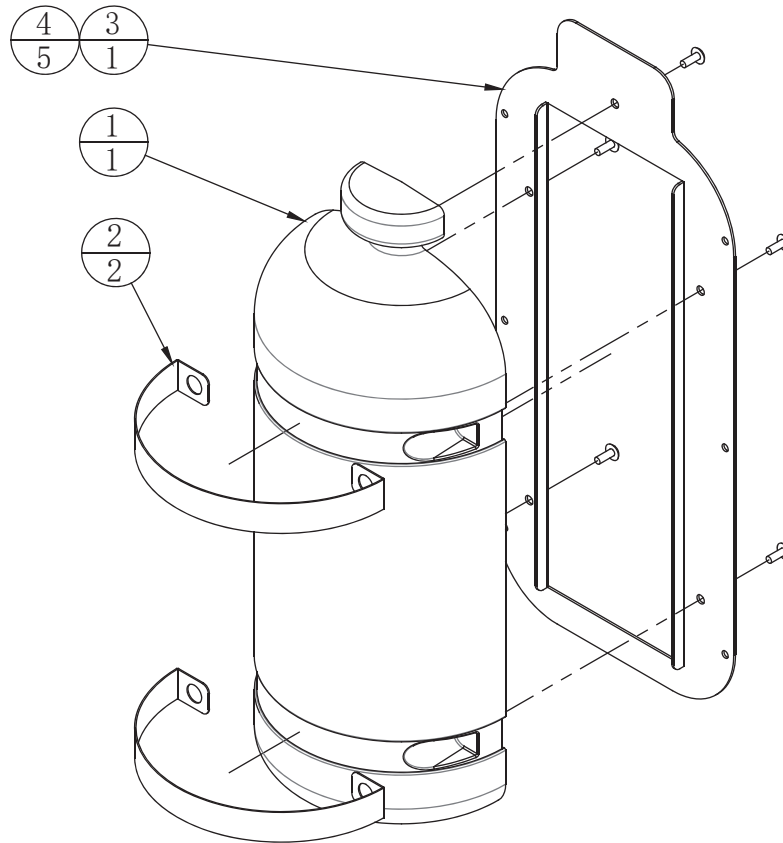

4		cross the big flat head screw	M5*12 (chrome)	5	
3	A9DX-0408A02	Nitrogen bottle fixing plate	SUS304-1.5T	1	1.1.IG39A00860
2	A9DX-0408A01	Oxygen cylinder decorative sheet	SUS304-0.8T	2	1.1.IG39A00850
1	A9DX-0408C01	Injection nitrogen bottle	PC	1	1.8.IG39A00090
No.	Draw No.	Name	Material/Spec.	Qty.	Product Code

6.6.9 Long slide-rail group (A9DX-0409000)

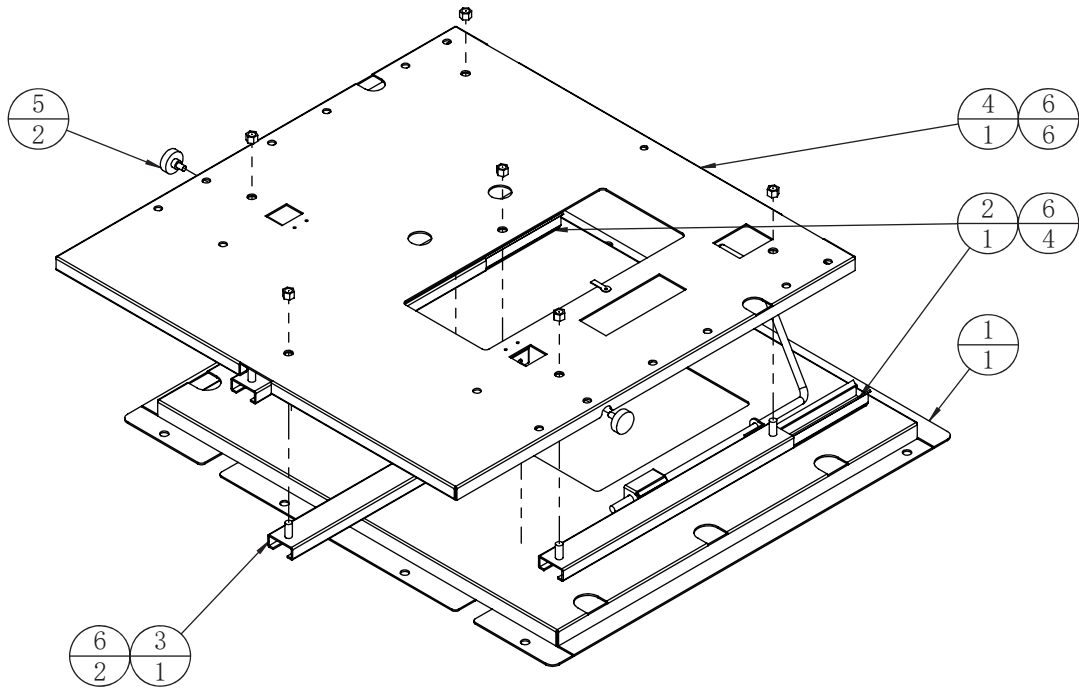

6		Self-Locking Nuts	M8 (Galvanization)	12	
5		Plastic guide wheel	6X26X8POM	2	1.4.ZC000062
4	A9DX-0409A02	Rail seat		1	1.1.IG39A00880
3		Auxiliary slide rail group	L=345 trip 239	0	1.4.HG100072
2		Long slide rail group	L=345 trip 240	1	1.4.HG100070
1	A9DX-0409A01	Sliding rail lower seat fixing plate		1	1.1.IG39A00870
No.	Draw No.	Name	Material/Spec.	Qty.	Product Code

6.7 Platform pedal assembly(A9DX-0500000)

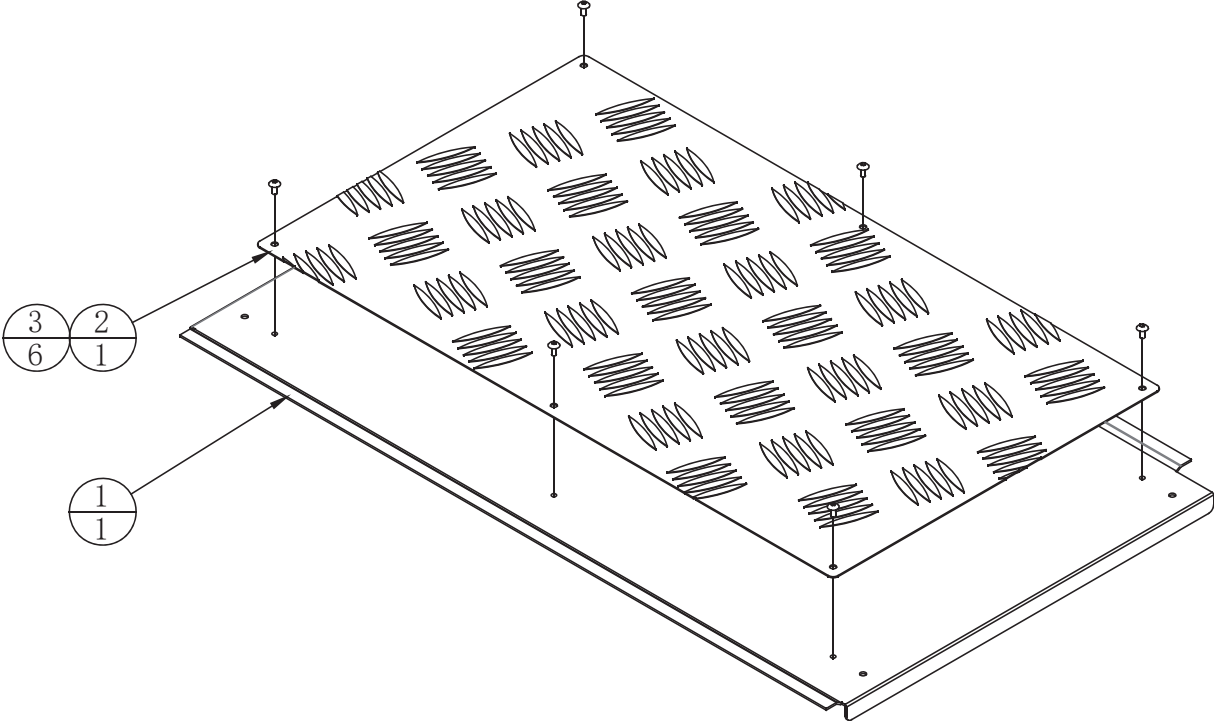

3		hex socket cap screws	M4*8 (chrome)	6	
2	A9DX-0500A02	Non-slip aluminum plate	Aluminum plate	1	1.1.IG39A00900
1	A9DX-0500A01	pedal cover plate	SPCC-1.5T	1	1.1.IG39A00890
No.	Draw No.	Name	Material/Spec.	Qty.	Product Code

6.8 Cashbox assembly(A9DX-0600000)

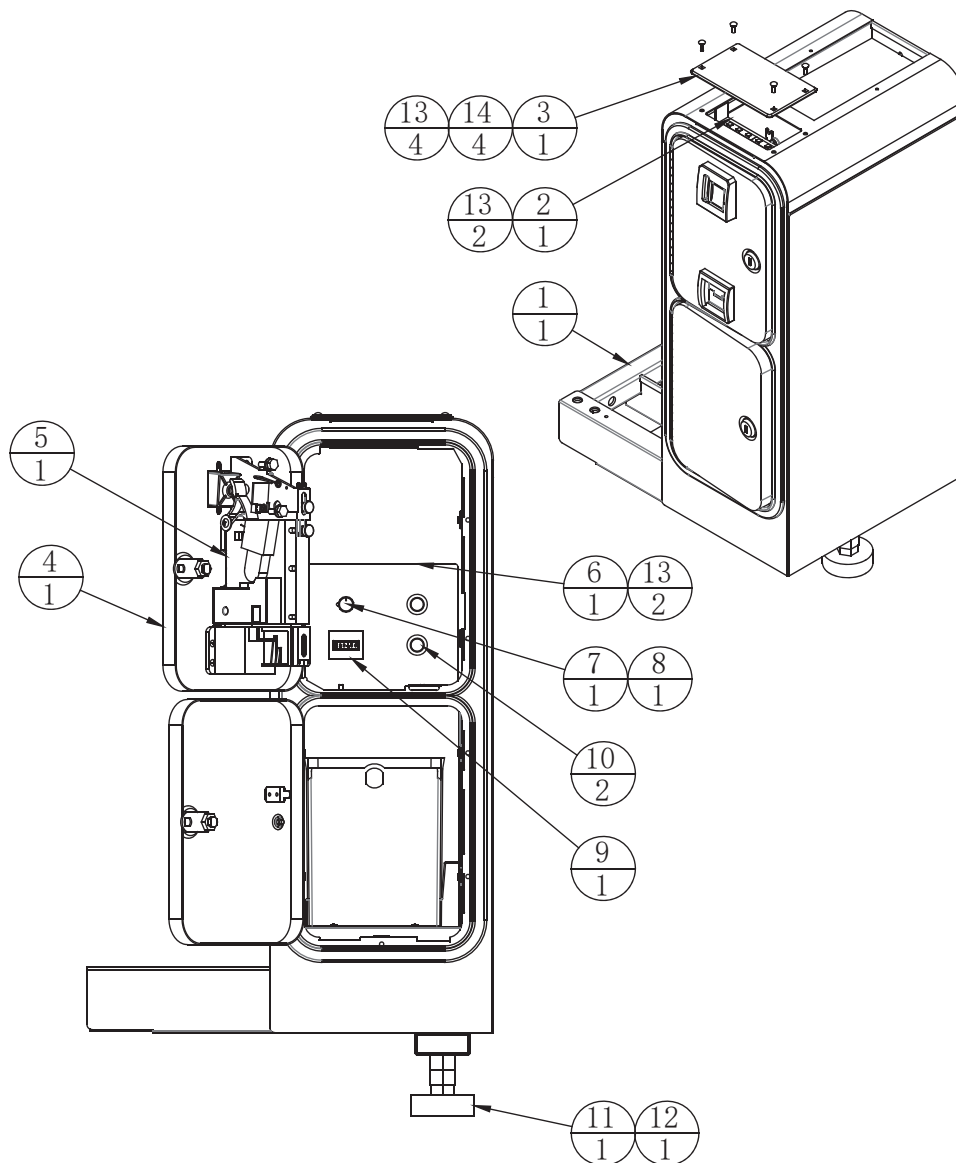

14		The carriage screws	M4*12 (chrome)	4	
13		hex head cap screw	M4 (Colour)	8	
12		hexagon nut	M16 (Colour)	1	
11		anchor bolt (rubber bottom)	M16*100(Colour)	1	
10		round push button	Red SDP-103C- 22RB	2	1.4.AJ500012#
9		counter	DC 12V	1	1.4.JS100020
8		potentiometer knob	Φ13mm	1	1.4.VR201310
7		volume vr components	VR-B10KΩ	1	1.4.VR160010
6	HXD-0213A01	control panel	SPCC-1.2T	1	1.1.IG19G00580
5		electronic coin	TW-800III	1	1.4.TB100050
4	TYM-0000000A	Single slot door set (black)		1	
3	A9DX-P0011	Cash box prompt decoration	PMMA-3.0T	1	1.7.IG39A00220
2	A9DX-0601000	Cashbox & light bar assembl		1	
1	A9DX-0600A01	Cash box frame		1	1.1.IG39A00910
No.	Draw No.	Name	Material/Spec.	Qty.	Product Code

6.8.1 Cashbox & light bar assembly(A9DX-0601000)

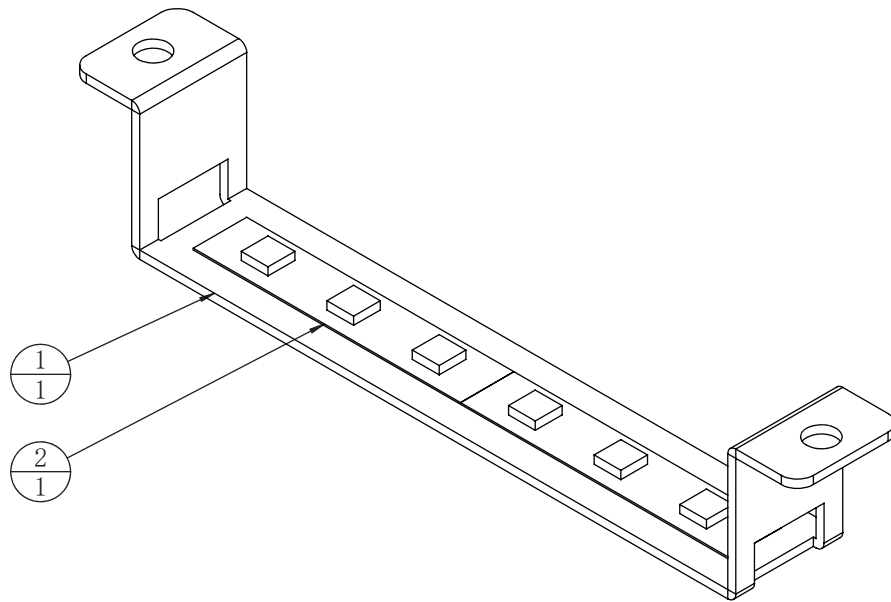

2		5050 strip light	DC12V 60 Light L=100mm	1	1.4.ZM9E0811
1	A9DX-0601A01	Fixing plate for light bar of cash box	SPCC-1.2T	1	1.1.IG39A00920
No.	Draw No.	Name	Material/Spec.	Qty.	Product Code

6.9 Top light box assembly(A9DX-0700000)

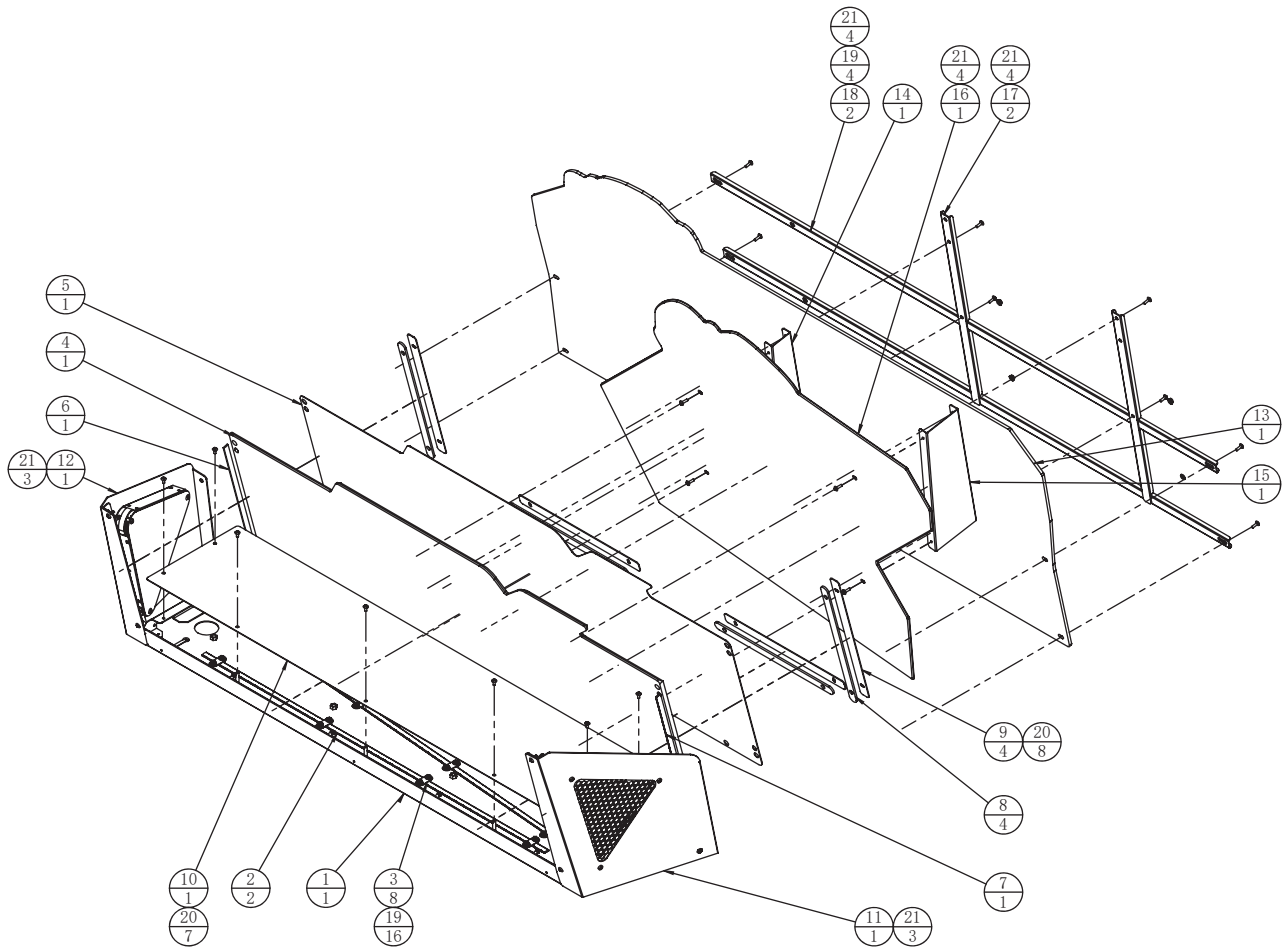

21		cross the big flat head screw	M4*12 (chrome)	18	
20		cross the big flat head screw	M4*8 (Black)	15	
19		hex head cap screw	M4 (Colour)	16	
18	A9DX-0700A06	Light box support plate 2	SPCC-1.5T	2	1.1.IG39A01070
17	A9DX-0700A05	Light box support plate 1	SPCC-1.5T	2	1.1.IG39A01060
16	A9DX-P0013	Light box background decoration	PMMA-3.0T	1	1.7.IG39A00240
15	A9DX-0700A03	Haoka board fixing frame 1	SPCC-1.2T	1	1.1.IG39A00950
14	A9DX-0700A04	Haoka board fixing frame 2	SPCC-1.2T	1	1.1.IG39A00960
13	A9DX-P0012	Light box background board	Andy board-5.0T	1	1.7.IG39A00230
12	A9DX-0702000	Light assembly on the left side of the light box		1	
11	A9DX-0701000	Light assembly on the right side of light box		1	
10	A9DX-0700D05	Light box protective cover	PVC-1.0T	1	1.7.IG39A00130
9	A9DX-0700A02	Acrylic fixing strip	SPCC-1.2T	4	1.1.IG39A00940
8	A9DX-0700D04	Acrylic washer	PMMA-3.0T	4	1.7.IG39A00120
7		5050 strip light	DC12V 60 Light L=250mm	1	1.4.ZM9E1820
6		5050 strip light	DC12V 60 Light L=1250mm	1	1.4.ZM9E2070
5	A9DX-0700D03	Machine name PVC board	PVC-1.0T	1	1.7.IG39A00110
4	A9DX-P0003	Theme light box	PMMA-8.0T	1	1.7.IG39A00140
3	A9DX-0700D01	Light fixing PVC board	PVC-1.0T	8	1.7.IG39A00100
2		5050 strip light	DC12V 60 Light L=800mm	2	1.4.ZM9E0069
1	A9DX-0700A01	Top light box fixing plate		1	1.1.IG39A00930
No.	Draw No.	Name	Material/Spec.	Qty.	Product Code

6.9.1 Light assembly on the right side of light box (A9DX-0701000)

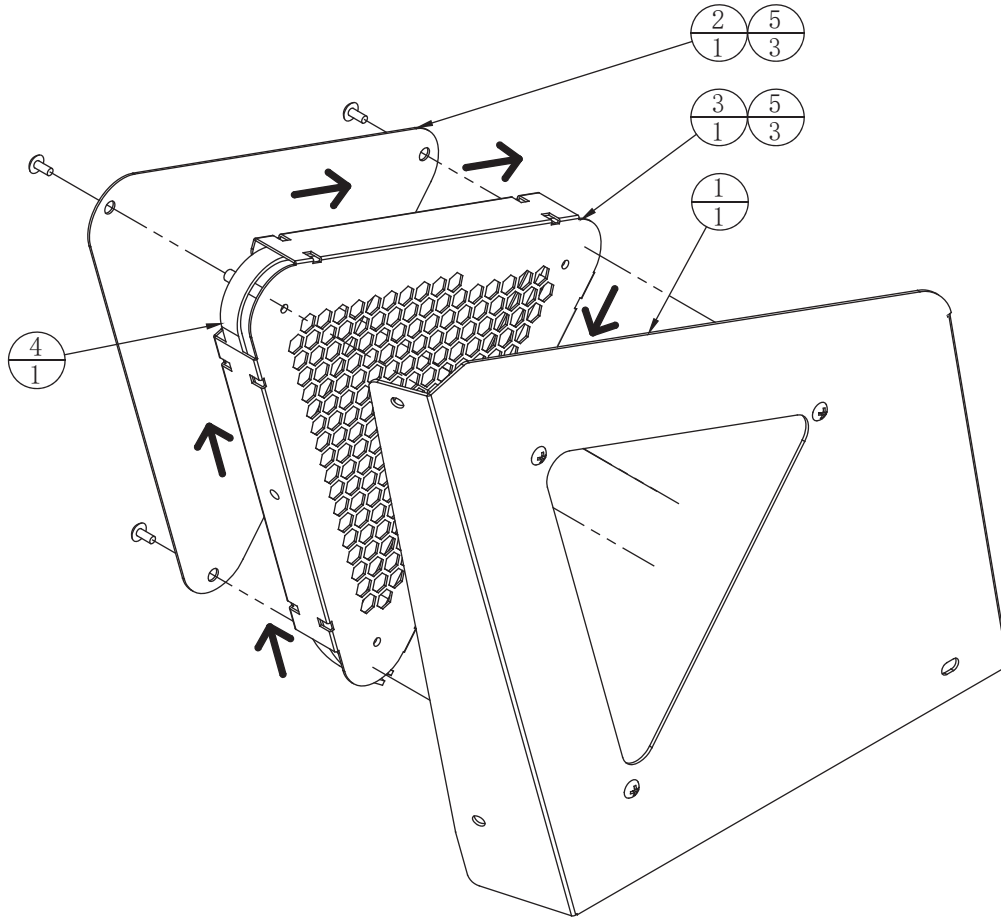

5		cross the big flat head screw	M4*8 (chrome)	6	
4		5050 strip light (Ipd6803chip)	DC12V RGB30 Light L=600mm	1	1.4.ZM9E2080
3	A9DX-0701A03	Decorative light bar fixing plate	SPCC-1.0T	1	1.1.IG39A00990
2	A9DX-0701A02	Decorative light strip cover plate	SPCC-1.0T	1	1.1.IG39A00980
1	A9DX-0701A01	Dengxiang sheet metal right	SUS304-1.5T	1	1.1.IG39A00970
No.	Draw No.	Name	Material/Spec.	Qty.	Product Code

6.9.2 Light assembly on the left side of the light box(A9DX-0702000)

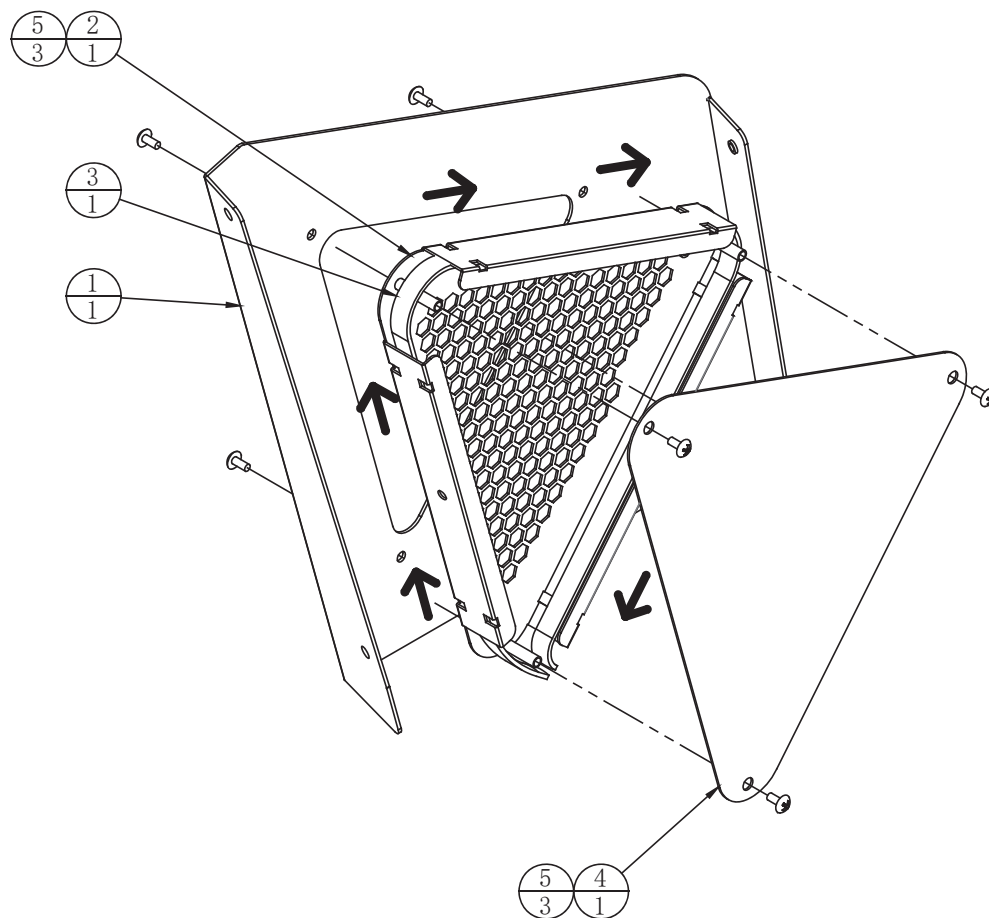

5		cross the big flat head screw	M4*8 (chrome)	6	
4	A9DX-0701A02	Decorative light strip cover plate	SPCC-1.0T	1	1.1.IG39A00980
3		5050 strip light (lpd6803chip)	DC12V RGB 30 Light L=600mm	1	1.4.ZM9E2080
2	A9DX-0701A03	Decorative light bar fixing plate	SPCC-1.0T	1	1.1.IG39A00990
1	A9DX-0702A01	Dengxiang car body panel repair left	SUS304-1.5T	1	1.1.IG39A01000
No.	Draw No.	Name	Material/Spec.	Qty.	Product Code

6.10 Maintenance door assembly(A9DX-0800000)

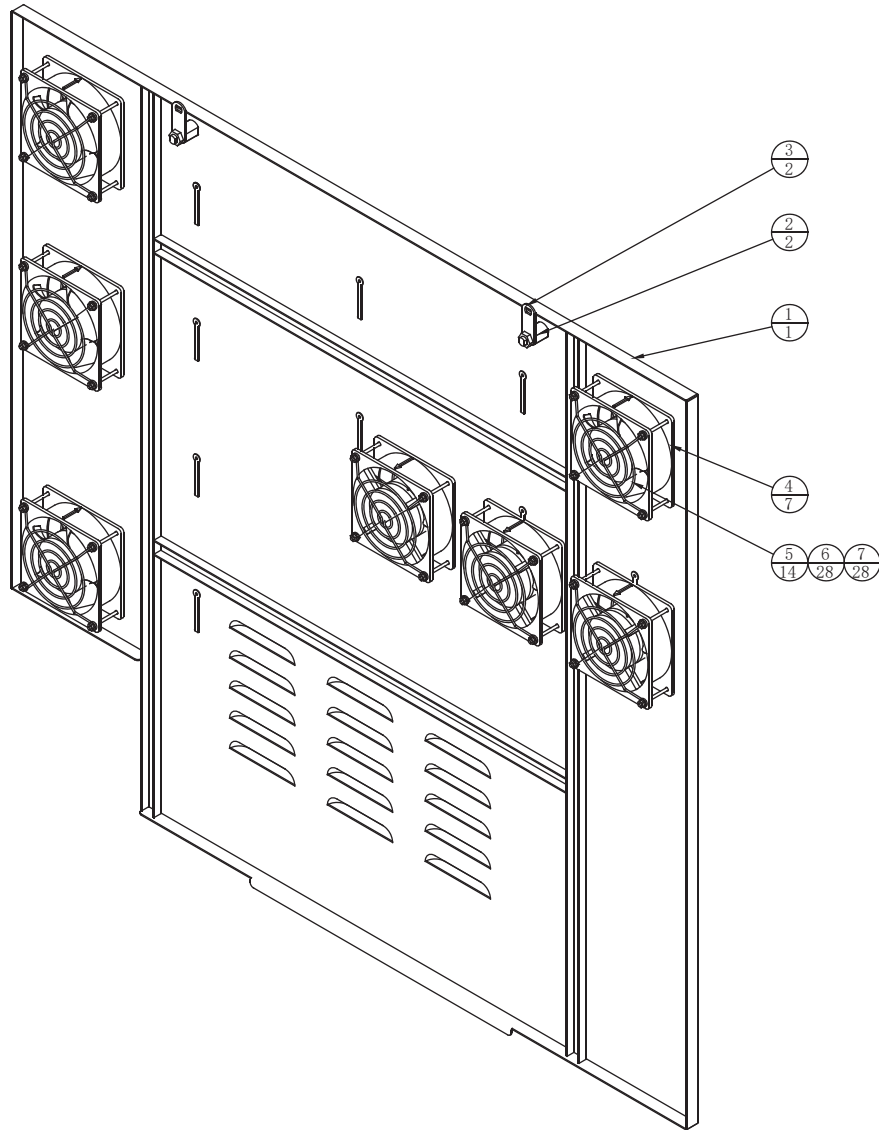

7		hex head cap screw	M4 (Colour)	28	
6		cross the big flat head screw	M4*50 (stainless steel)	28	
5		fan cover	120*120	14	1.4.FS300020
4		fan with bearing	120*120/AC110V	7	1.4.FS200042
3		locking plate	Three hole straight piece	2	1.4.SJ120018
2		Lingzhi door lock (21.5mm)	1810S	2	1.4.SJ120011
1	A9DX-0800A01	Maintenance door		1	1.1.IG39A01010
No.	Draw No.	Name	Material/Spec.	Qty.	Product Code

7. Printing Pattern

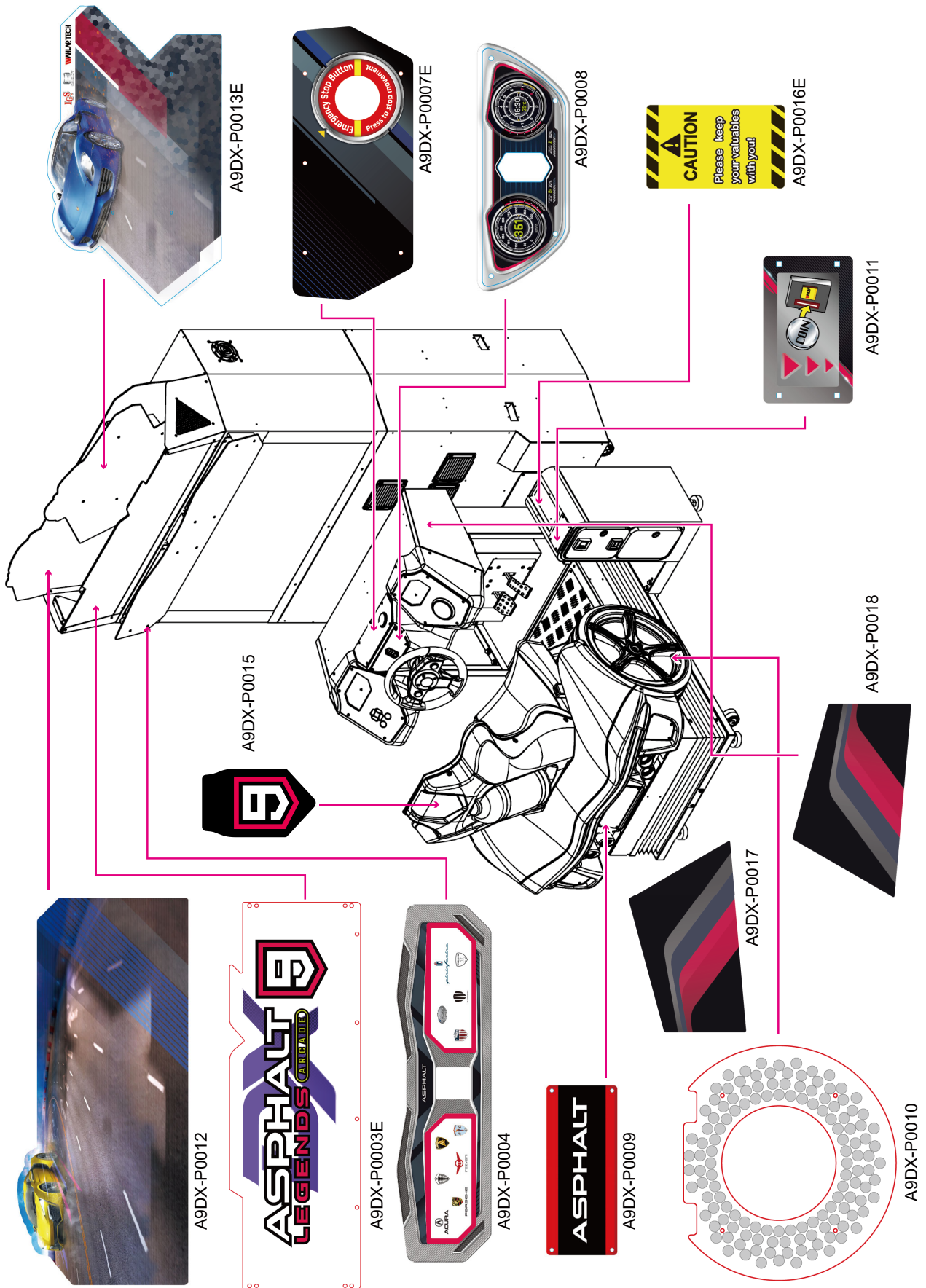

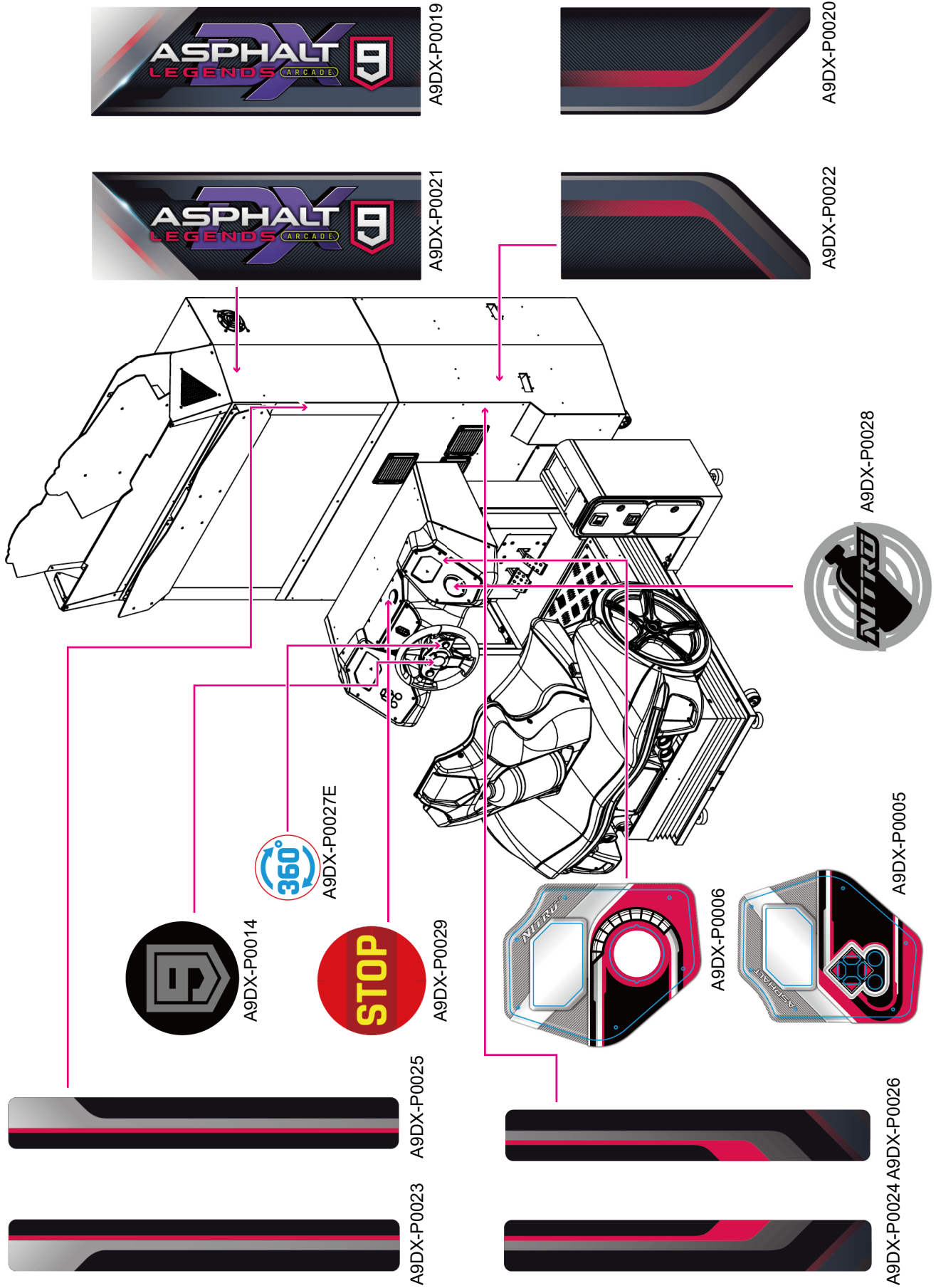

8. Wiring Diagram

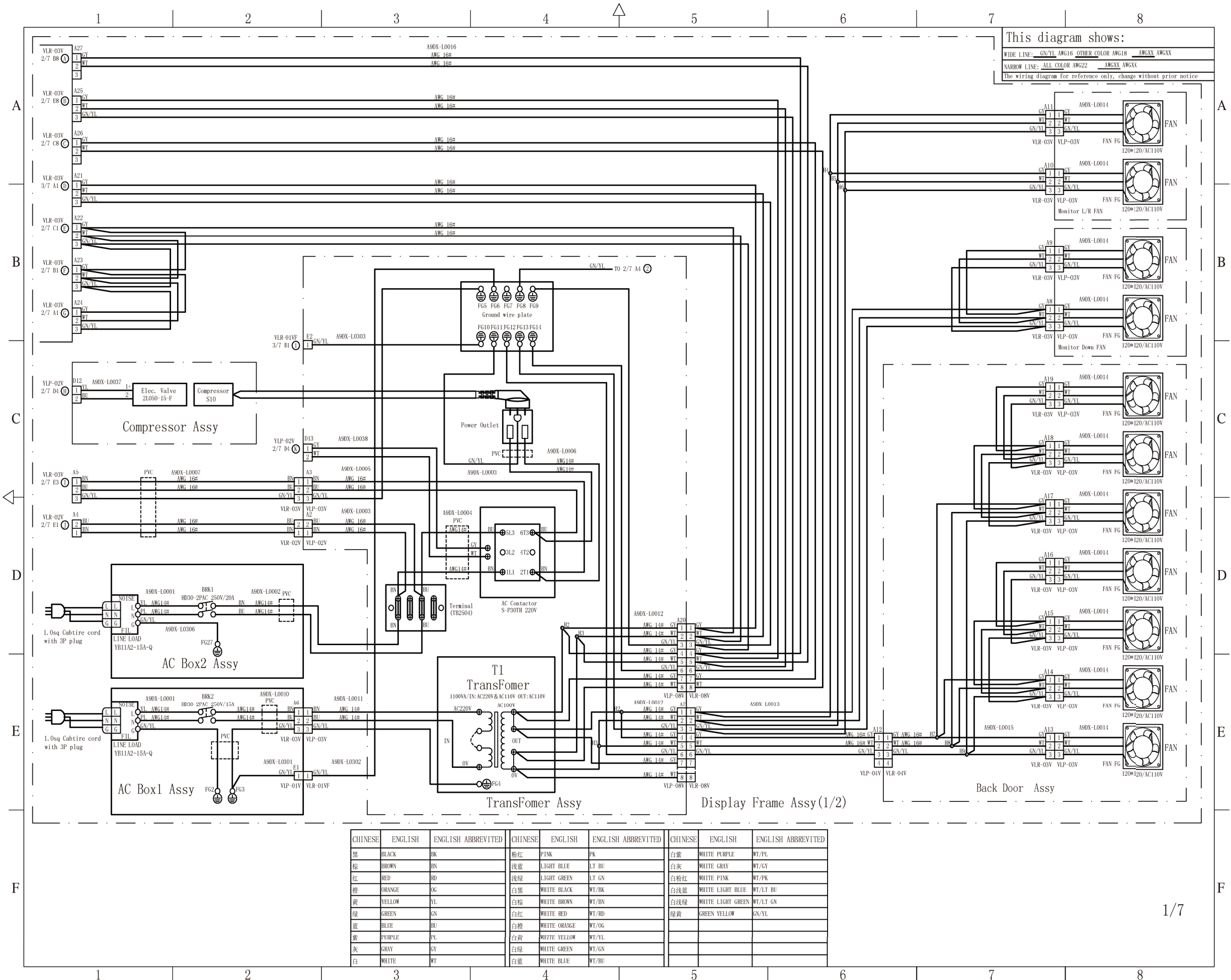

This diagram shows:
 WIDE LINE: GN/YL, AWG16 OTHER COLOR AWG18 AWGXX AWGXX
 NARROW LINE: ALL COLOR AWG22 AWGXX AWGXX
 The wiring diagram for reference only, change without prior notice

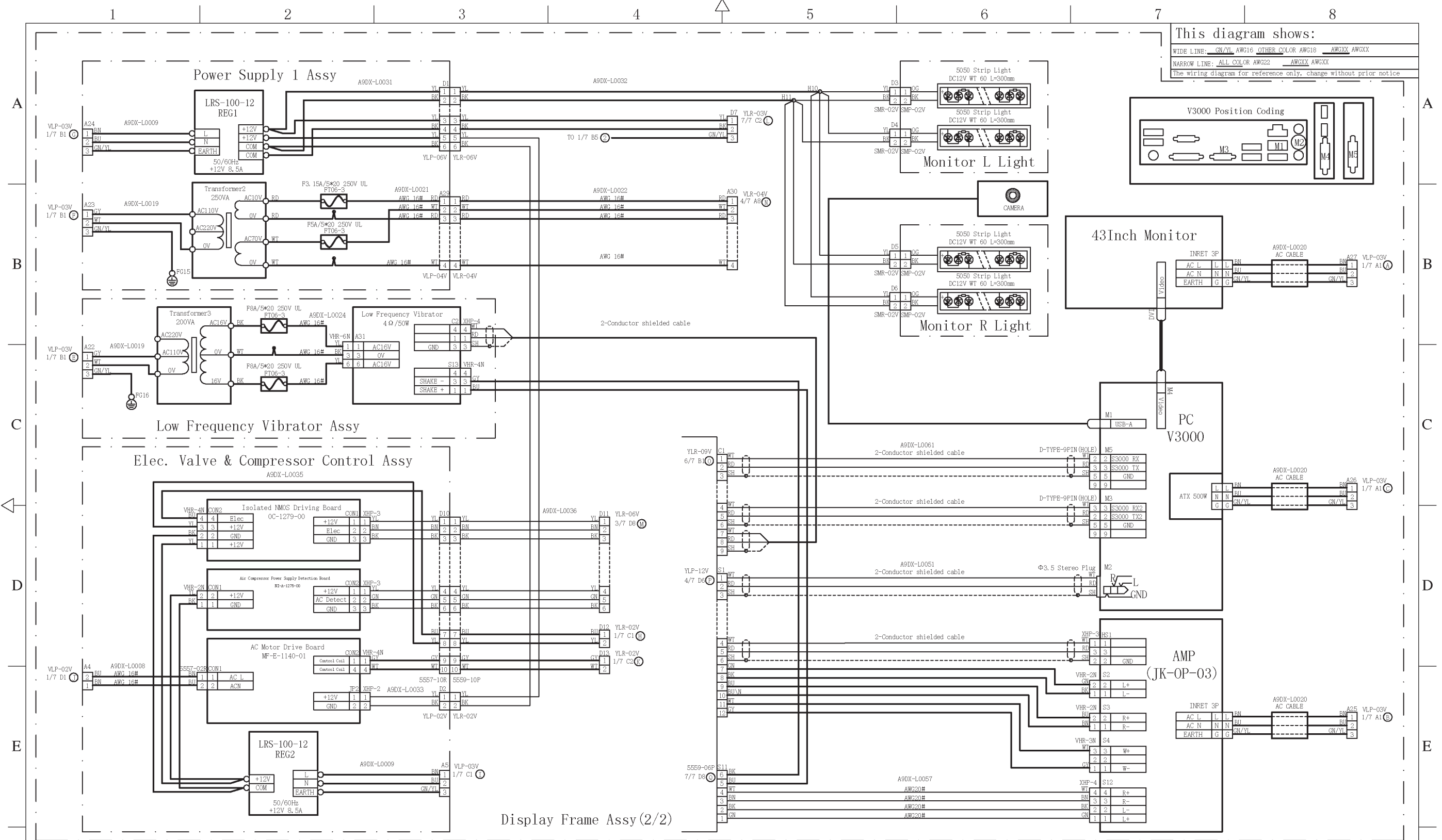

CHINESE	ENGLISH	ENGLISH ABBREVIATED	CHINESE	ENGLISH	ENGLISH ABBREVIATED	CHINESE	ENGLISH	ENGLISH ABBREVIATED
黑	BLACK	BK	粉红	PINK	PK	白紫	WHITE PURPLE	WT/PL
棕	BROWN	BN	浅蓝	LIGHT BLUE	LT BU	白灰	WHITE GRAY	WT/GY
红	RED	RD	浅绿	LIGHT GREEN	LT GN	白粉红	WHITE PINK	WT/PK
橙	ORANGE	OG	白黑	WHITE BLACK	WT/BK	白浅蓝	WHITE LIGHT BLUE	WT/LT BU
黄	YELLOW	YL	白棕	WHITE BROWN	WT/BN	白浅绿	WHITE LIGHT GREEN	WT/LT GN
绿	GREEN	GN	白红	WHITE RED	WT/RD	绿黄	GREEN YELLOW	GN/YL
蓝	BLUE	BU	白橙	WHITE ORANGE	WT/OG			
紫	PURPLE	PL	白黄	WHITE YELLOW	WT/YL			
灰	GRAY	GY	白绿	WHITE GREEN	WT/GN			
白	WHITE	WT	白蓝	WHITE BLUE	WT/BU			

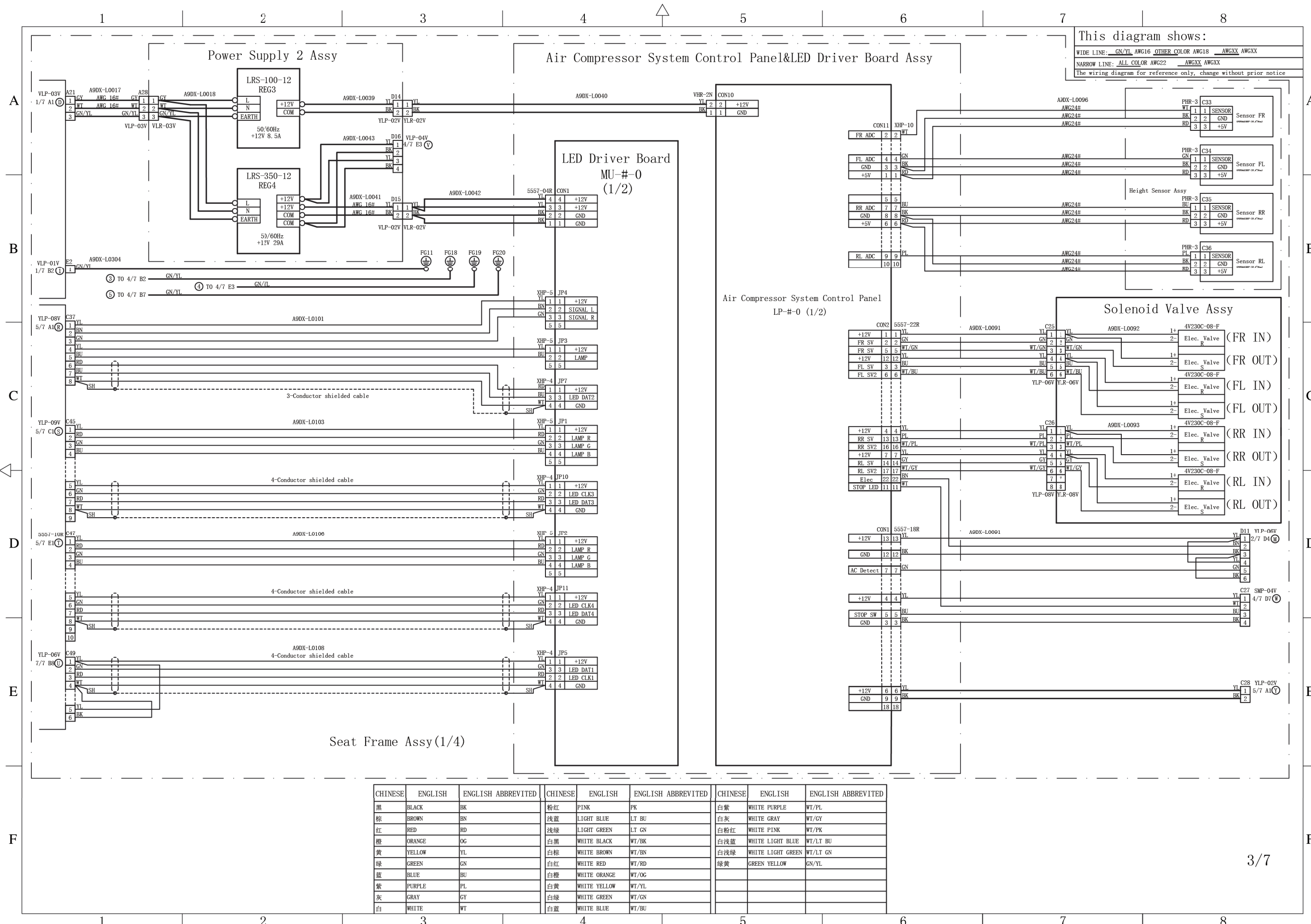

This diagram shows:
 WIDE LINE: GN/YL AWG16 OTHER COLOR AWG18 AWGXX AWGXX
 NARROW LINE: ALL COLOR AWG22 AWGXX AWGXX
 The wiring diagram for reference only, change without prior notice

CHINESE	ENGLISH	ENGLISH ABBREVIATED	CHINESE	ENGLISH	ENGLISH ABBREVIATED	CHINESE	ENGLISH	ENGLISH ABBREVIATED
黑	BLACK	BK	粉红	PINK	PK	白紫	WHITE PURPLE	WT/PL
棕	BROWN	BN	浅蓝	LIGHT BLUE	LT BU	白灰	WHITE GRAY	WT/GY
红	RED	RD	浅绿	LIGHT GREEN	LT GN	白粉红	WHITE PINK	WT/PK
橙	ORANGE	OG	白黑	WHITE BLACK	WT/BK	白浅蓝	WHITE LIGHT BLUE	WT/LT BU
黄	YELLOW	YL	白棕	WHITE BROWN	WT/BN	白浅绿	WHITE LIGHT GREEN	WT/LT GN
绿	GREEN	GN	白红	WHITE RED	WT/RD	绿黄	GREEN YELLOW	GN/YL
蓝	BLUE	BU	白橙	WHITE ORANGE	WT/OG			
紫	PURPLE	PL	白黄	WHITE YELLOW	WT/YL			
灰	GRAY	GY	白绿	WHITE GREEN	WT/GN			
白	WHITE	WT	白蓝	WHITE BLUE	WT/BU			

This diagram shows:
 WIDE LINE: GN/YL AWG16 OTHER COLOR AWG18 AWGXX AWGXX
 NARROW LINE: ALL COLOR AWG22 AWGXX AWGXX
 The wiring diagram for reference only, change without prior notice

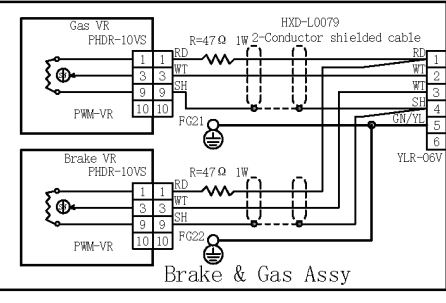
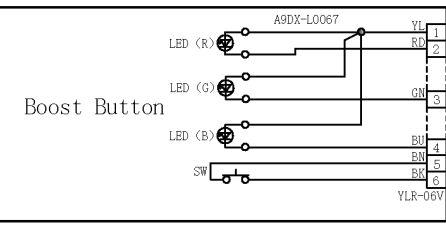
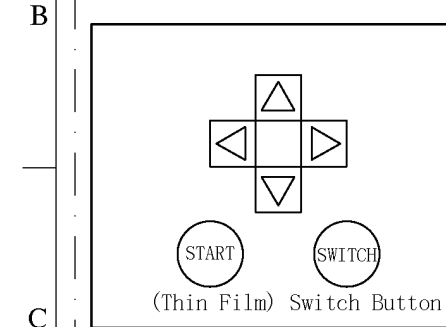
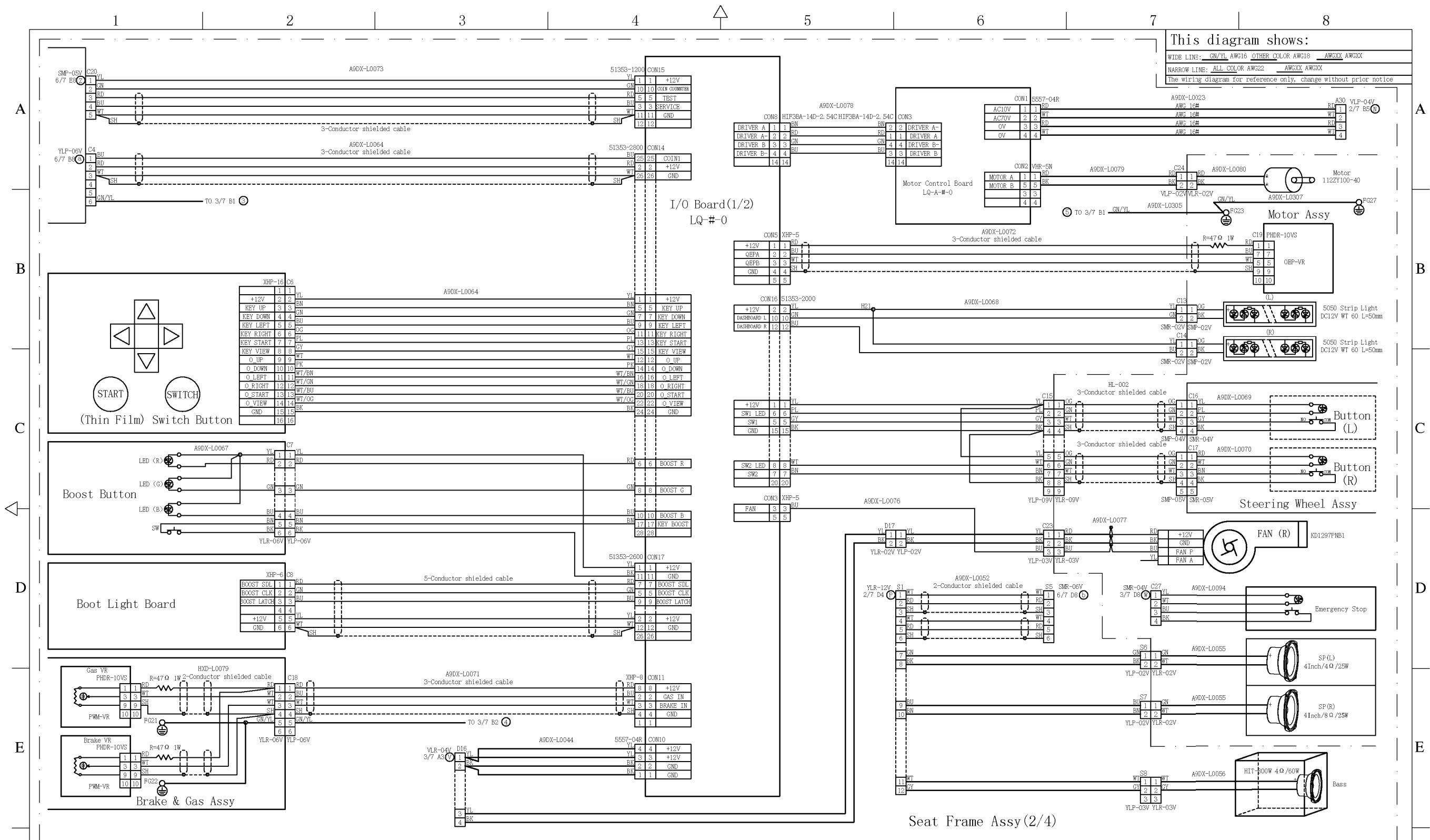

CHINESE	ENGLISH	ENGLISH ABBREVIATED	CHINESE	ENGLISH	ENGLISH ABBREVIATED	CHINESE	ENGLISH	ENGLISH ABBREVIATED
黑	BLACK	BK	粉红	PINK	PK	白紫	WHITE PURPLE	WT/PL
棕	BROWN	BN	浅蓝	LIGHT BLUE	LT BU	白灰	WHITE GRAY	WT/GY
红	RED	RD	浅绿	LIGHT GREEN	LT GN	白粉	WHITE PINK	WT/PK
橙	ORANGE	OC	白黑	WHITE BLACK	WT/BK	白浅蓝	WHITE LIGHT BLUE	WT/LT BU
黄	YELLOW	YL	白棕	WHITE BROWN	WT/BN	白浅绿	WHITE LIGHT GREEN	WT/LT GN
绿	GREEN	GN	白红	WHITE RED	WT/RD	绿黄	GREEN YELLOW	GN/YL
蓝	BLUE	BU	白橙	WHITE ORANGE	WT/OC			
紫	PURPLE	PL	白黄	WHITE YELLOW	WT/YL			
灰	GRAY	GY	白绿	WHITE GREEN	WT/GN			
白	WHITE	WT	白蓝	WHITE BLUE	WT/BU			

This diagram shows:
 WIDE LINE: GN/YL AWG16 OTHER COLOR AWG18 AWGX AWGXX
 NARROW LINE: ALL COLOR AWG22 AWGX AWGXX
 The wiring diagram for reference only, change without prior notice

Seat Frame Assy(3/4)

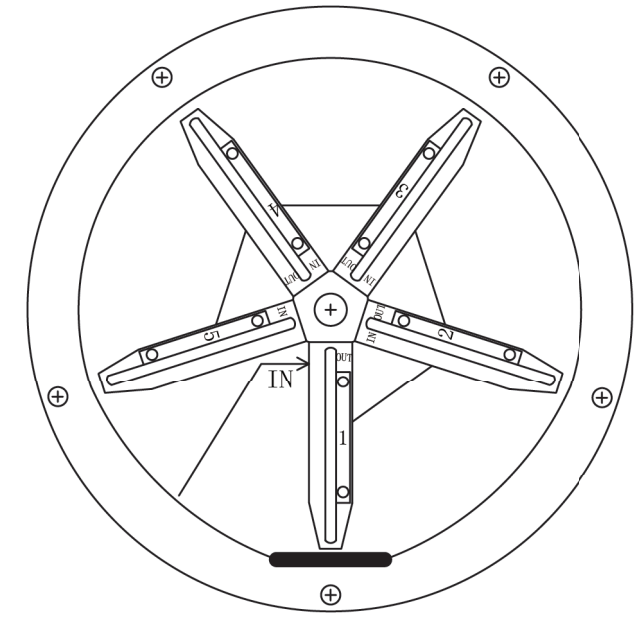

Wheel Frame Lamp(L/R) Positive View

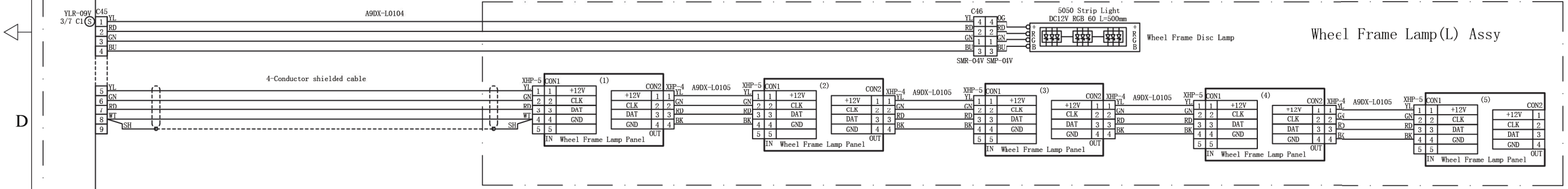
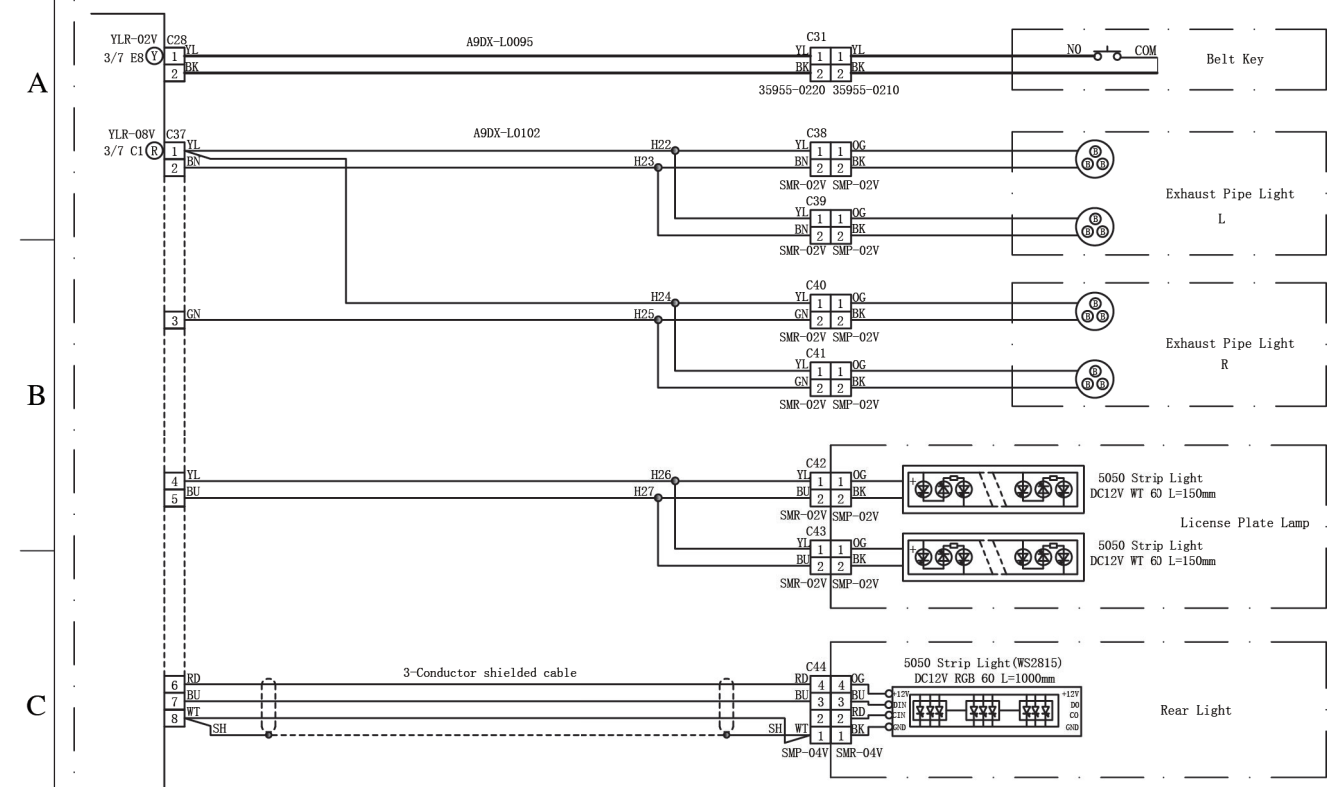

Wheel Frame Lamp(L) Assy

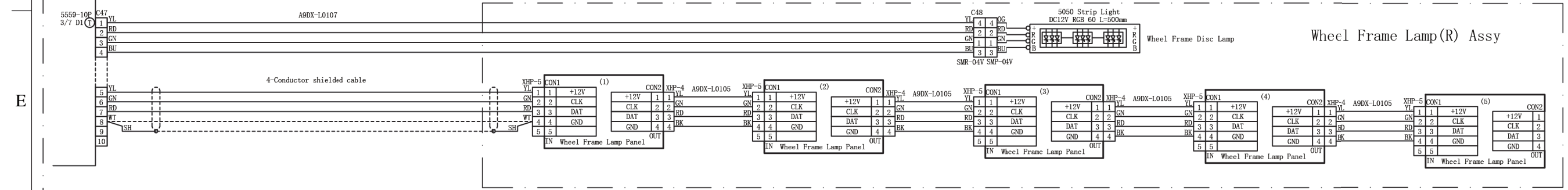

Wheel Frame Lamp(R) Assy

CHINESE	ENGLISH	ENGLISH ABBREVIATED	CHINESE	ENGLISH	ENGLISH ABBREVIATED	CHINESE	ENGLISH	ENGLISH ABBREVIATED
黑	BLACK	BK	粉红	PINK	PK	白紫	WHITE PURPLE	WT/PL
棕	BROWN	BN	浅蓝	LIGHT BLUE	LT BU	白灰	WHITE GRAY	WT/GY
红	RED	RD	浅绿	LIGHT GREEN	LT GN	白粉红	WHITE PINK	WT/PK
橙	ORANGE	OG	白黑	WHITE BLACK	WT/BK	白浅蓝	WHITE LIGHT BLUE	WT/LT BU
黄	YELLOW	YL	白棕	WHITE BROWN	WT/BN	白浅绿	WHITE LIGHT GREEN	WT/LT GN
绿	GREEN	GN	白红	WHITE RED	WT/RD	绿黄	GREEN YELLOW	GN/YL
蓝	BLUE	BU	白橙	WHITE ORANGE	WT/OG			
紫	PURPLE	PL	白黄	WHITE YELLOW	WT/YL			
灰	GRAY	GY	白绿	WHITE GREEN	WT/GN			
白	WHITE	WT	白蓝	WHITE BLUE	WT/BU			

This diagram shows:
 WIDE LINE: GN/YL AWG16 OTHER COLOR AWG18 AWGXX AWGXX
 NARROW LINE: ALL COLOR AWG22 AWGXX AWGXX
 The wiring diagram for reference only, change without prior notice

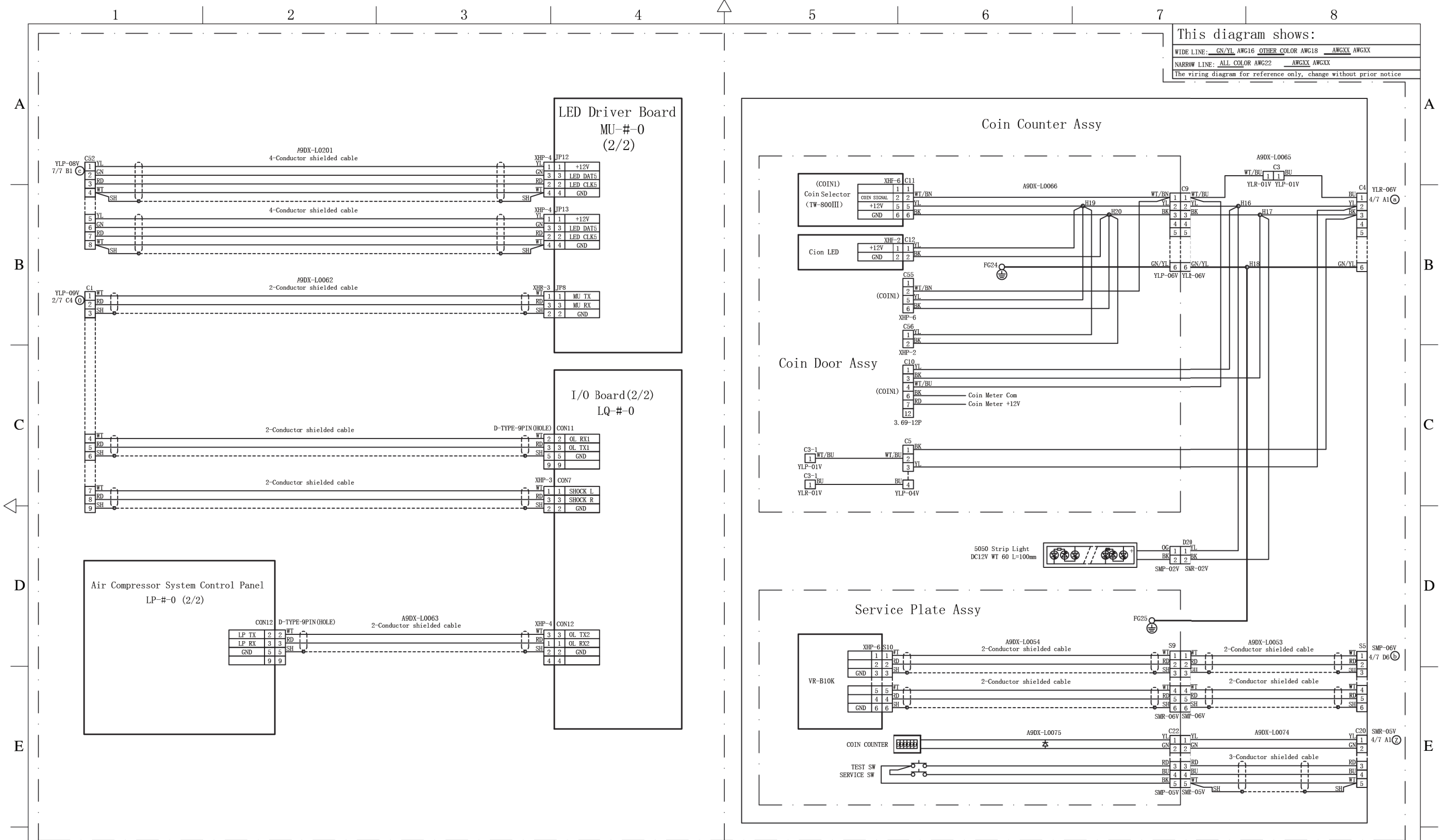

CHINESE	ENGLISH	ENGLISH ABBREVIATED	CHINESE	ENGLISH	ENGLISH ABBREVIATED	CHINESE	ENGLISH	ENGLISH ABBREVIATED
黑	BLACK	BK	粉红	PINK	PK	白紫	WHITE PURPLE	WT/PL
棕	BROWN	BN	浅蓝	LIGHT BLUE	LT BU	白灰	WHITE GRAY	WT/GY
红	RED	RD	浅绿	LIGHT GREEN	LT GN	白粉红	WHITE PINK	WT/PK
橙	ORANGE	OG	白黑	WHITE BLACK	WT/BK	白浅蓝	WHITE LIGHT BLUE	WT/LT BU
黄	YELLOW	YL	白棕	WHITE BROWN	WT/BN	白浅绿	WHITE LIGHT GREEN	WT/LT GN
绿	GREEN	GN	白红	WHITE RED	WT/RD	绿黄	GREEN YELLOW	GN/YL
蓝	BLUE	BU	白橙	WHITE ORANGE	WT/OG			
紫	PURPLE	PL	白黄	WHITE YELLOW	WT/YL			
灰	GRAY	GY	白绿	WHITE GREEN	WT/GN			
白	WHITE	WT	白蓝	WHITE BLUE	WT/BU			

This diagram shows:
 WIDE LINE: GN/YL AWG16 OTHER COLOR AWG18 AWGXX AWGXX
 NARROW LINE: ALL COLOR AWG22 AWGXX AWGXX
 The wiring diagram for reference only, change without prior notice

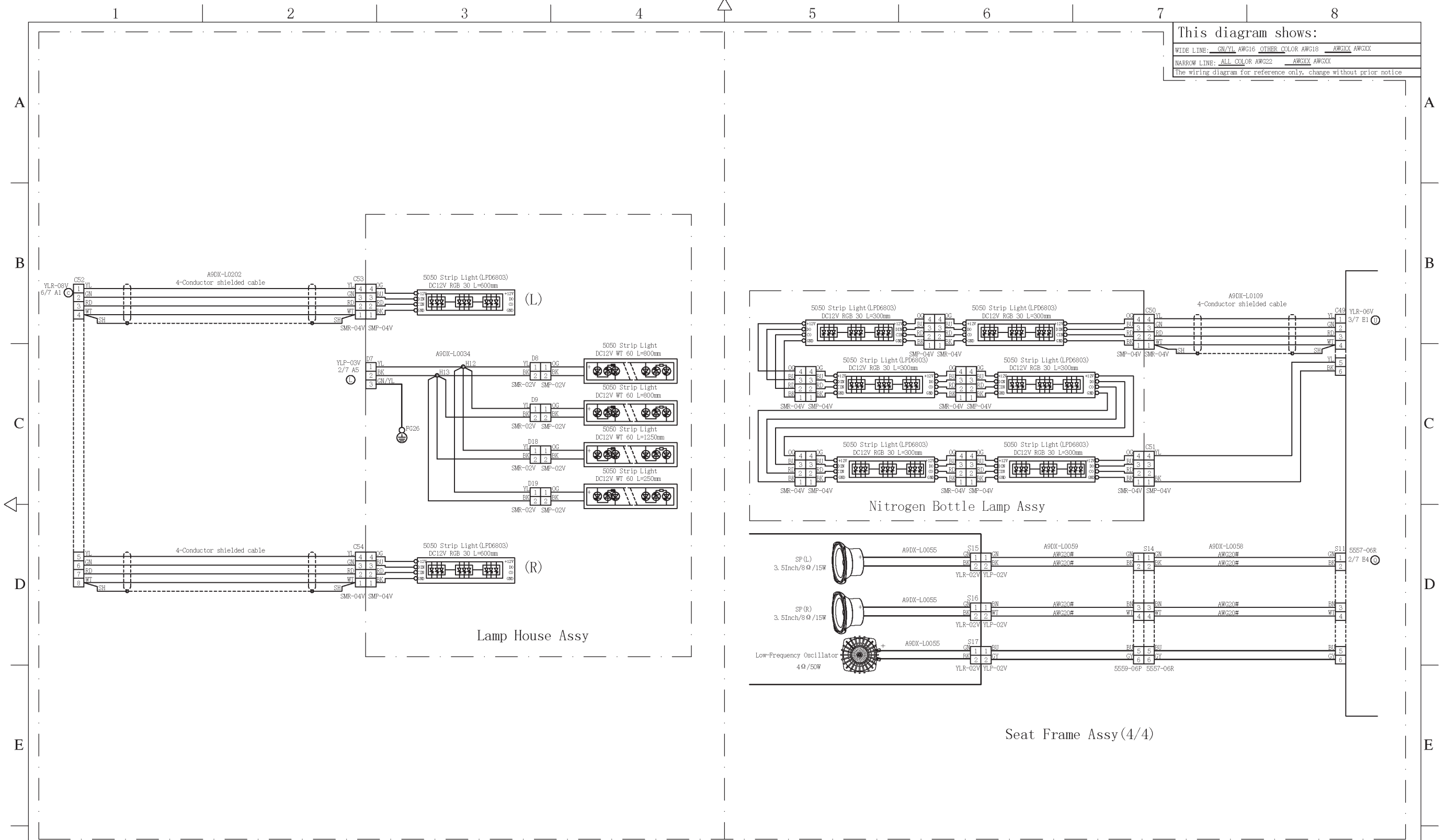

CHINESE	ENGLISH	ENGLISH ABBREVIATED	CHINESE	ENGLISH	ENGLISH ABBREVIATED	CHINESE	ENGLISH	ENGLISH ABBREVIATED
黑	BLACK	BK	粉红	PINK	PK	白紫	WHITE PURPLE	WT/PL
棕	BROWN	BN	浅蓝	LIGHT BLUE	LT BU	白灰	WHITE GRAY	WT/GY
红	RED	RD	浅绿	LIGHT GREEN	LT GN	白粉红	WHITE PINK	WT/PK
橙	ORANGE	OG	白黑	WHITE BLACK	WT/BK	白浅蓝	WHITE LIGHT BLUE	WT/LT BU
黄	YELLOW	YL	白棕	WHITE BROWN	WT/BN	白浅绿	WHITE LIGHT GREEN	WT/LT GN
绿	GREEN	GN	白红	WHITE RED	WT/RD	绿黄	GREEN YELLOW	GN/YL
蓝	BLUE	BU	白橙	WHITE ORANGE	WT/OG			
紫	PURPLE	PL	白黄	WHITE YELLOW	WT/YL			
灰	GRAY	GY	白绿	WHITE GREEN	WT/GN			
白	WHITE	WT	白蓝	WHITE BLUE	WT/BU			

After-sales Service

Honorable customer !

Thank you for purchasing our product !
For your benefits , if you find any fault during the operation of the product, please use a technician who obtains a certificate related to mechanical engineering , electrical engineering or who engages in routine maintenance , repair and management of amusement machine to check the machine and inform us the fault in a timely manner. Our company will take corresponding measures to assist you to solve the problem promptly.

NOTICE: Do not dismount or replace any part of the machine without our technician's permission, or you will solely undertake the consequence !

Please pay attention to our contact information as follow:

Guangzhou Wahlap Technology Corporation Limited

Add: NO.28,Lianyun 2nd heng Road,Shiqi Town,Panyu District,
Guangzhou City,China.

Tel: +86 20 39226222 Fax: +86 20 39226300

Service Hotline: 400-848-9222

<http://www.wahlap.com>

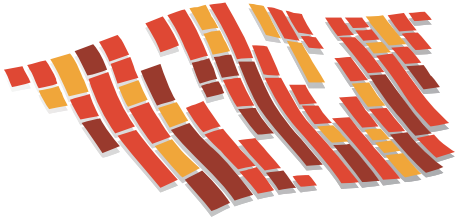

A9DX-P0036E



WHLAP TECH

IGS[®]

The machine specifications or the information in this operation manual may be change without prior notice.
For inquiries regarding the machine or machine repairs, please contact your distributor. ※